



牙刀系列



- 碳化鎢鋼牙刀
- 合金鋼牙刀
- 外徑牙刀
- 模組化刀頭牙刀

Zy 內徑牙刀 Internal Threading Boring Bars

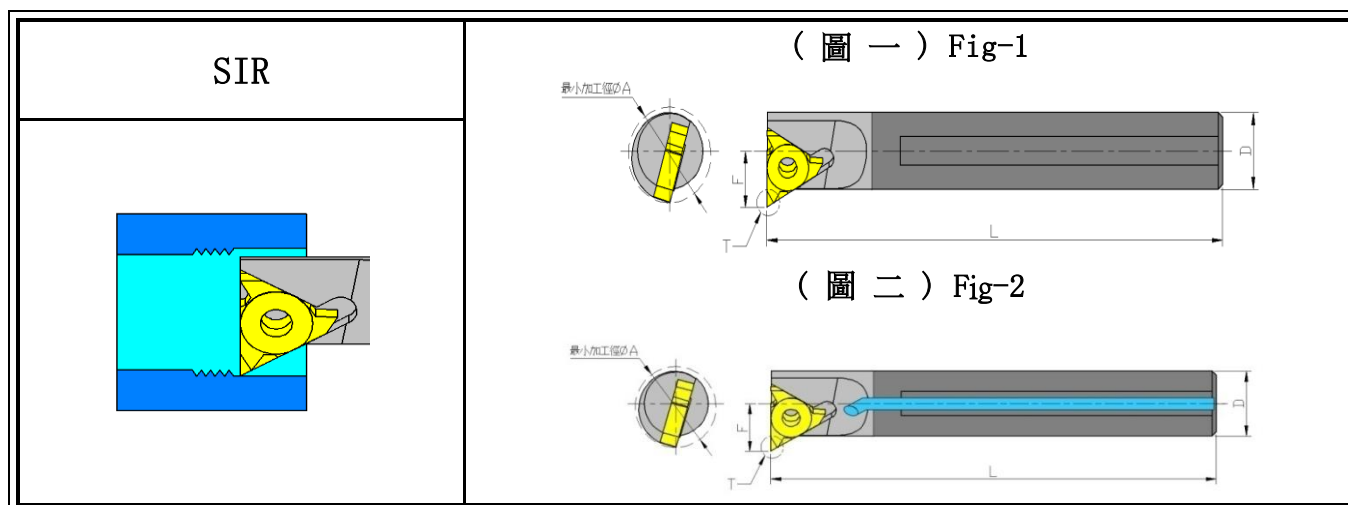

Stock	型號 Model No.	最小加工徑	F	D	L	墊片 Shim	墊片 Shim	螺絲 Screw	板手 Wrench	刀片 Insert
鎢鋼柄 (圖一) Carbide Shank (Fig-1)										
●	SIR/L0005H-06C-064	6.4	3.98	5	100	-	-	M2x5.0x2.6	T6	06NR/L
●	SIR/L0006J-06C-076	7.6	4.48	6	110	-	-	M2.2x5.1x3.1	T7	08NR/L
●	SIR/L0008K-08C-10	10	5.9	8	125	-	-	M2.5x6.0x3.6	T8	11NR/L
●	SIR/L0010M-11C-12	12	7.4	10	150	-	-	M3.5x7.6x5.1-60	T15	16NR/L
●	SIR/L0012M-11C-15	15	8.5	12	150	-	-			
●	SIR/L0014M-16C-18	18	10.6	14	150	-	-			
●	SIR/L0016M-16C-19	19	11.7	16	150	-	-			
●	SIR/L0016R-16C-19	19	11.7	16	200	-	-	M4x15.9x7.0	T15	22NR/L
●	SIR/L0020R-16C-24	24	13.7	20	200	-	-			
●	SIR/L0020S-16C-24	24	13.7	20	250	-	-			
●	SIR/L0025R-16C-29	29	16.2	25	200	GXN16	HTM305	M3.5x11.4x5.1	T15	22NR/L
○	SIR/L0032R-16C-36	36	18.8	32	200	GXN16	HTM305			
○	SIR/L0032R-22C-40	40	20.95	32	200	SNR22	HTM306	M4x15.9x7.0	T15	22NR/L
合金鋼柄 (圖一) Alloy Steel (Fig-1)										
●	SINR1008-08	10	5.91	8	125	-	-	M2.2x5.1x3.1	T7	08NR/L
●	SINR1210-11	12	7.4	10	125			M2.5x6.0x3.6	T8	11NR/L
●	SINR1512-11	15	8.5	12	150			M3.5x7.6x5.1-60	T15	16NR/L
●	SINR2016-16	20	11.7	16	180			M3.5x7.6x5.1-60	T15	16NR/L

●	SINR2420-16	24	13.7	20	200					
●	SINR2925-16	29	16.2	25	200	GXN16	HTM305	M3.5x11.4x5.1		
鎢鋼柄 + 水孔 (圖二) Carbide Shank With Coolant (Fig-2)										
●	SIR/L0005H-06E-064	6.4	4.3	5	100	-	-	M2x5.0x2.6	T6	06NR/L
●	SIR/L0006J-06E-076	7.6	4.48	6	110					
●	SIR/L0008K-08E-10	10	5.9	8	125			M2.2x5.1x3.1	T7	08NR/L
●	SIR/L0010M-11E-12	12	7.4	10	150					
●	SIR/L0012M-11E-15	15	8.5	12	150			M2.5x6.0x3.6	T8	11NR/L
●	SIR/L0016R-16E-19	19	11.7	16	200					
高硬度柄 (Y:圖二、Z:圖一) High Hardness Steel With Coolant (Y:Fig-2、Z:Fig-1)										
○	SIR0010K-11Y-12	12	7.4	10	125	-	-	M2.5x6.0x3.6	T8	11NR/L
●	SIR0010K-11Z-12	12	7.4	10	125					
●	SIR0012M-11Y-15	15	8.5	12	150					
●	SIR0012M-11Z-15	15	8.5	12	150					
●	SIR0016N-16Y-19	19	11.7	16	160			M3.5x7.6x5.1-60	T15	16NR/L
○	SIR0016N-16Z-19	19			150					
○	SIR0016Q-16Y-19	19			180					
●	SIR0016Q-16Z-19	19			180					
●	SIR0020R-16Y-24	24	13.7	20	200					
●	SIR0020R-16Z-24	24	13.7	20	200					

●:庫存 In Stock ○:非標準庫存(請確認交貨期) Non-standard Stock

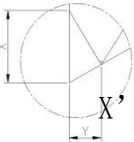
 <p>T 部詳圖 X' Y' 尺寸參考刀片 Insert 規格</p>					
型號 Model No.	最小螺紋	型號 Model No.	最小螺紋	型號 Model No.	最小螺紋
SIR0005H-06C-064	M8	SIR0012M-11C-15	M18	SIR0025S-16C-29	M33
SIR0008K-08C-10	M11	SIR0016M-16C-19(S)	M22		
SIR0010M-11C-12	M14	SIR0020R-16C-24(S)	M27		

Zy 縮小徑內徑牙刀 Internal Threading Boring Bars

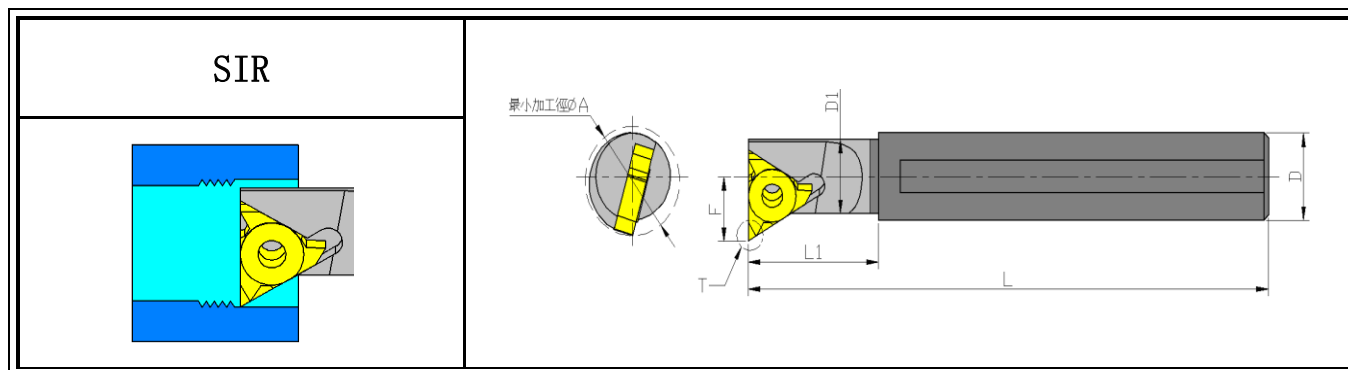

Stock	型號 Model No.	最小加工徑 A	F	D	D1	L	L1	螺絲 Screw	扳手 Wrench	刀片 Insert
鎢鋼柄 (圖一) Carbide Shank (Fig-1)										
●	SIR0008K-08C-09-20L	9	5	8	6.1	125	20	M2. 2x5. 1x3. 1	T7	08IR/L
●	SIR0008K-08C-10-20L	10	5.5	8	7.4	125	20			
合金鋼柄 (圖一) Alloy Steel (Fig-1)										
●	SINR0612-06-10L	6.4	4.3	12	5.1	125	10	M2x3. 7x2. 6-60	T6	06IR/L
●	SINR0816-08-18L	8	5	16	8	125	18	M2. 2x5. 1x3. 1	T7	08IR/L
●	SINR1012-11-25L	10	5.8	12	8.3	150	25	M2. 5x6. 0x3. 6	T8	11IR/L
●	SINR1216-11-25L	12	7.4	16	10	150	25			
●	SINR1516-11-30L	15	8.5	16	12	150	30			
高硬度柄 (Y:圖二、Z:圖一) High Hardness Steel With Coolant (Y:Fig-2、Z:Fig-1)										
●	SIR001206K-06Y-076-20L	7.6	4.48	12	6	125	20	M2x3. 7x2. 6-60	T6	06IR/L
●	SIR001206K-06Z-076-20L	7.6	4.48	12	6	125	20			
●	SIR001208H-11Z-10-25L	10	5.8	12	8.3	100	25	M2. 5x6. 0x3. 6	T8	11IR/L

●:庫存 In Stock ○:非標準庫存(請確認交貨期) Non-standard Stock

T 部詳圖

X' Y' 尺寸參考刀片 Insert 規格

型號 Model No.	最小螺紋
SIR0008K-08C-09-20L	M10
SIR0008K-08C-10-20L	M11

Zy 外徑牙刀 External Threading Turning Tools

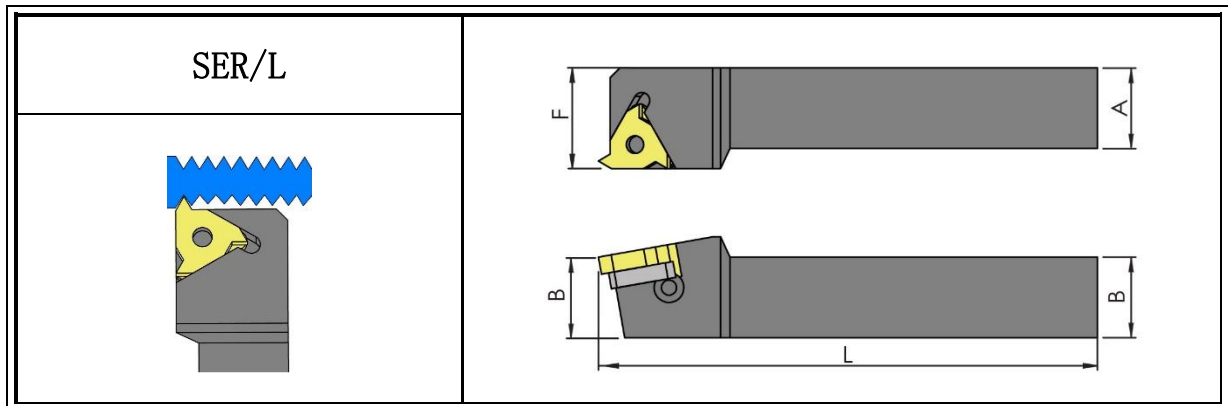



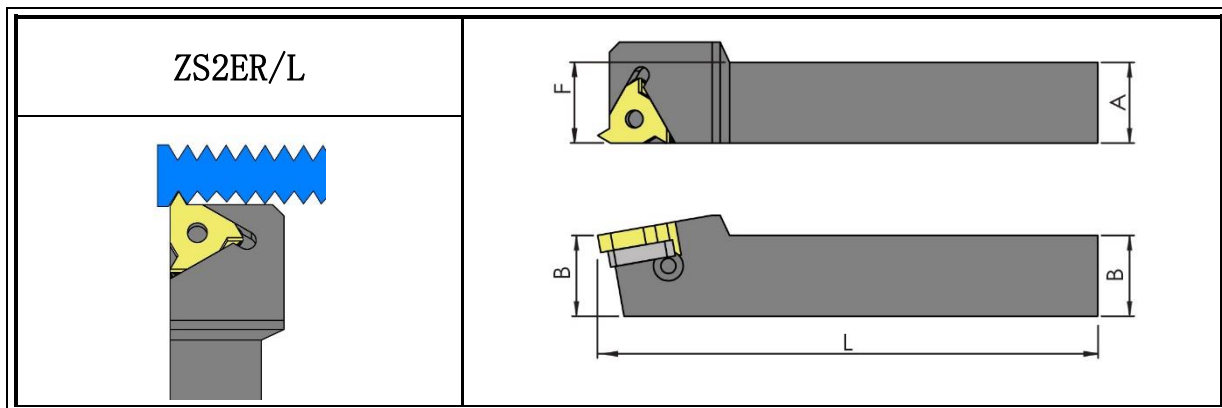

Stock	型號 Model No.	A	B	F	L	螺絲 Screw	墊片 Shim	螺絲 Shim Screw	板手 Wrench
●	SER-1616K-16	16	16	20	125	M3.5x11.4x5.1	GXE16 GXN16	M3	T15 L:2.5
●	SER-2020K-16	20	20	25	125				
●	SER-2525M-16	25	25	32	150				
●	SEL-1616K-16	16	16	20	125				
●	SEL-2020K-16	20	20	25	125				
●	SEL-2525M-16	25	25	32	150				

●:庫存 In Stock ○:非標準庫存(請確認交貨期) Non-standard Stock

Zy 外徑走心式牙刀 External Threading With Coolant For Automatic Lathes



Stock	型號 Model No.	A	B	F	L	 螺絲 Screw	 墊片 Shim	 螺絲 Shim Screw	 板手 Wrench
●	ZS2ER-1212K-16	12	12	12	125	M3.5x11.4x5.1	-	-	T15
●	ZS2ER-1616K-16	16	16	16	125		GXE16 GXN16	M3	T15 L:2.5

●:庫存 In Stock ○:非標準庫存(請確認交貨期) Non-standard Stock



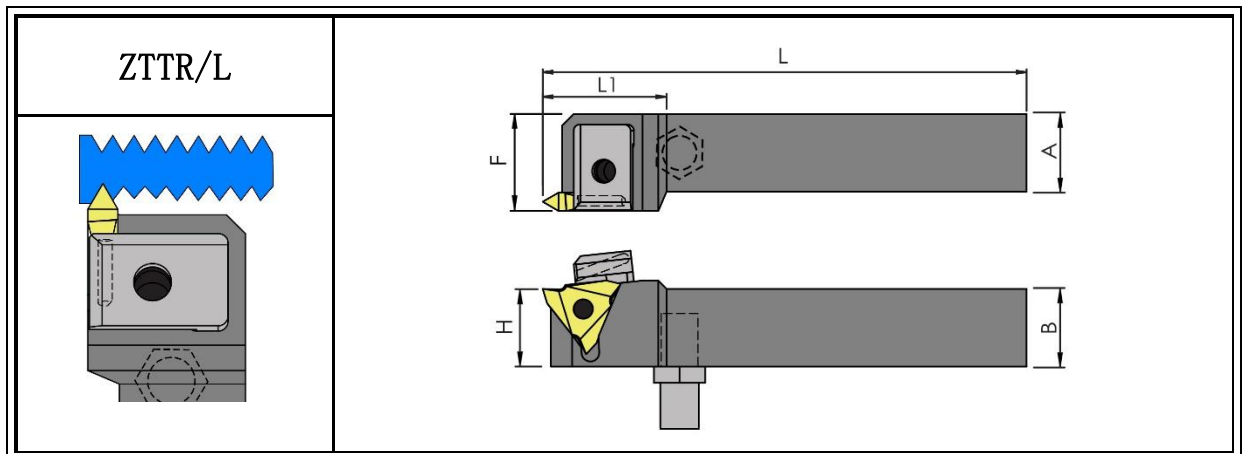



Zy 外徑牙刀 External Threading Turning Tools

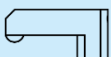

Stock	型號 Model No.	A	B	F	L	刀片 Insert
●	ZTTR/L-2020K-22	20	20	25	125	三菱
●	ZTTR/L-2525M-22	25	25	32	150	MTTR436002

●:庫存 In Stock ○:非標準庫存(請確認交貨期) Non-standard Stock

配件 Tool Parts :

 壓板 Clamp	 螺絲 Screw	 壓板螺絲 Clamp Screw	 螺絲 Clamp Screw	 彈簧 Spring	 板手 Wrench
ZMTK1R/L	M5x13L	M5x25L	DS625	SP5309	L3.0

Zy 模組化內徑牙刀頭 Modular Internal Threading Head With Coolant

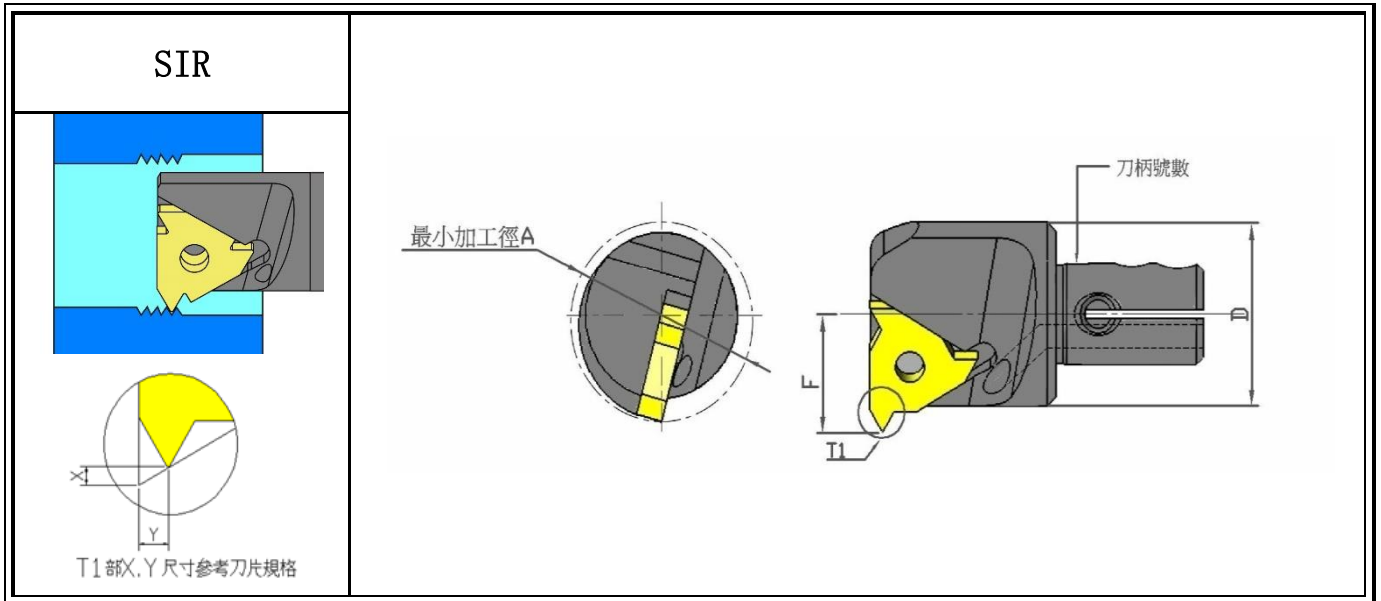

Stock	型號 Model No.	最小加工徑 A	F	D	L	 墊片 Shim	 墊片螺絲 Shim Screw	 螺絲 Screw	 板手 Wrench	刀片 Insert
●	SCK1-A20-SIR16-24	24	13.7	20	22	-	-	M3.5x7.6x5.1x60	T15	16NR/L
●	SCK2-A25-SIR16-29	29	16.2	25	27	STM16R	M3	M3.5x12.0x5.4x6		
●	SCK3-A32-SIR16-36	36	19.7	32	32	STM16R	M3	7		
●	SCK1-A20-SIR22-25	25	13.5	20	22	-	-	M4x11.1x6.8	T15	22NR/L
●	SCK2-A25-SIR22-32	32	18.1	25	27	-	-			
○	SCK3-A32-SIR22-40	40	20.95	32	32	STM22R	M4			