

模組化系統

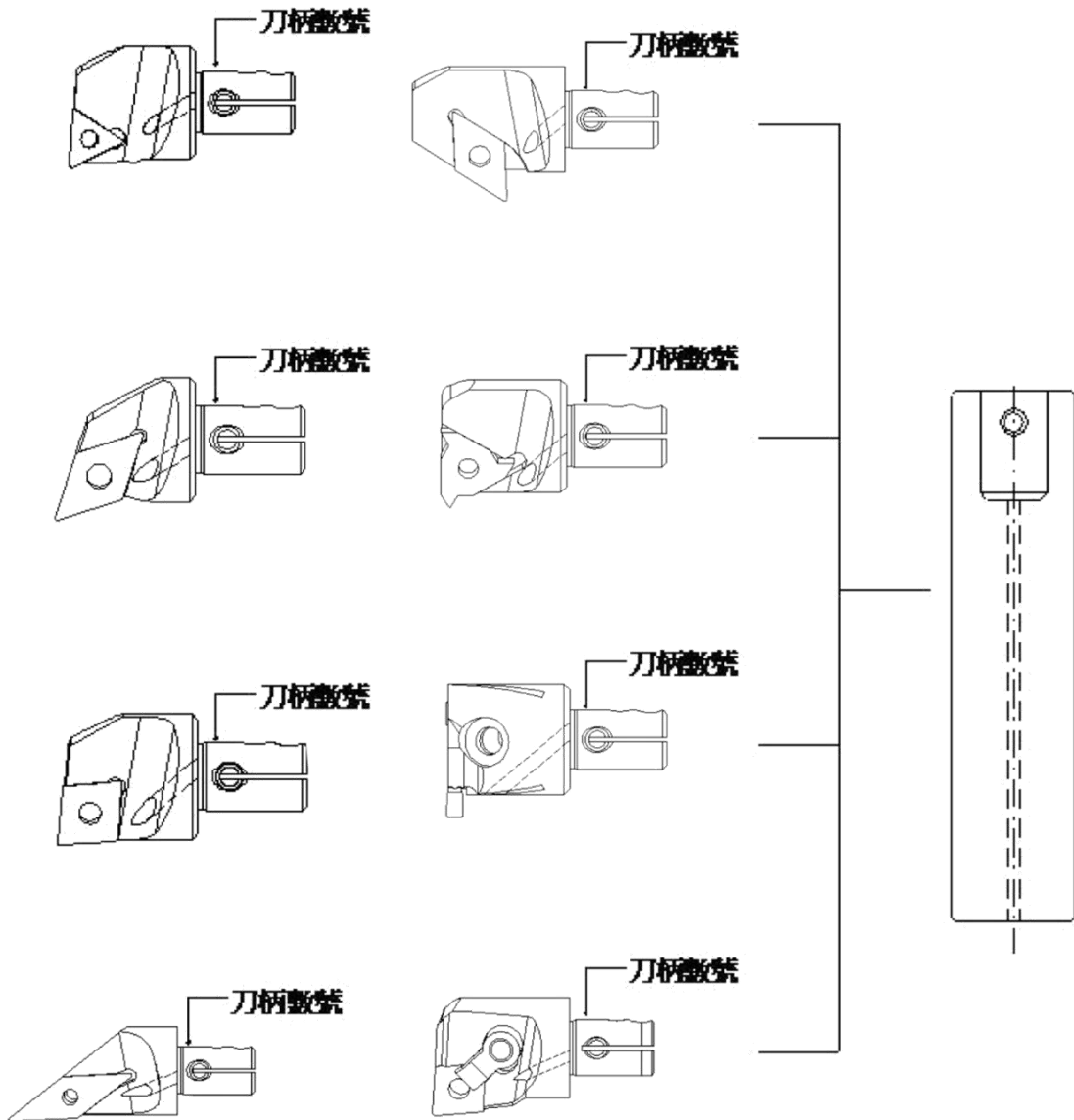

模組刀桿的使用價值

※ 價值一. 高鋼性,刀桿穩定,可延長刀片壽命 ※



超合金高硬度處理,產生高鋼性刀桿.



※ 價值二. 多樣選擇,減少重複購買 ※

一顆刀頭
可裝在不同材質,長度的刀桿上

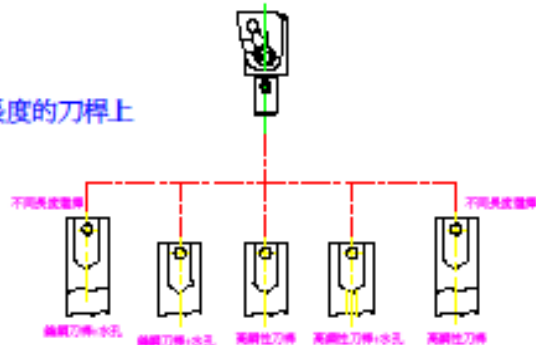

一支刀桿
可裝上不同功能性的刀頭

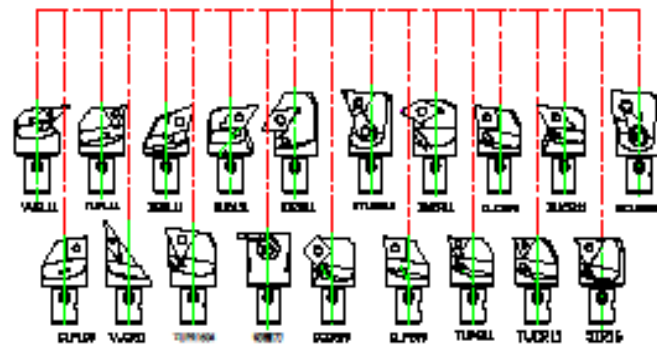

※ 價值三. 讓刀尖高度更準確,加工更穩定 ※

V槽與鋼珠的定
位結構,讓刀尖高
度準確

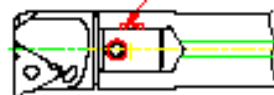

※ 價值四. 便宜 ※

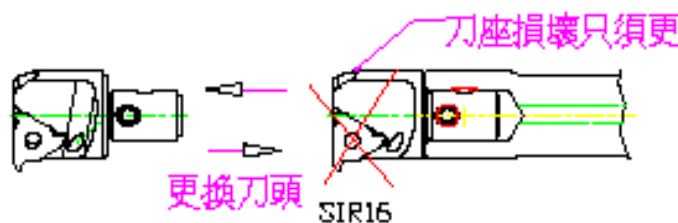

模組化刀桿及刀頭裝配步驟

軸向徑向貼合緊密

模組機構刀頭

裝配步驟 一.

鎖緊上下的固定螺絲。

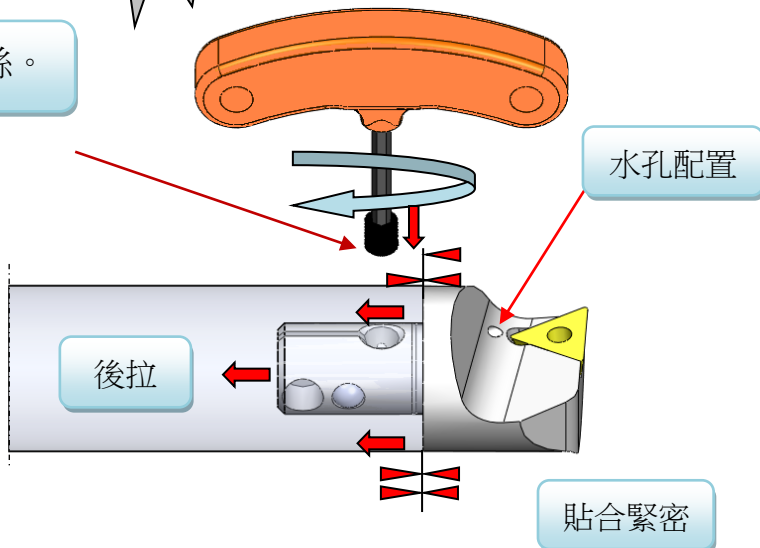

裝配步驟 二.

鎖緊第三孔頂開螺絲。

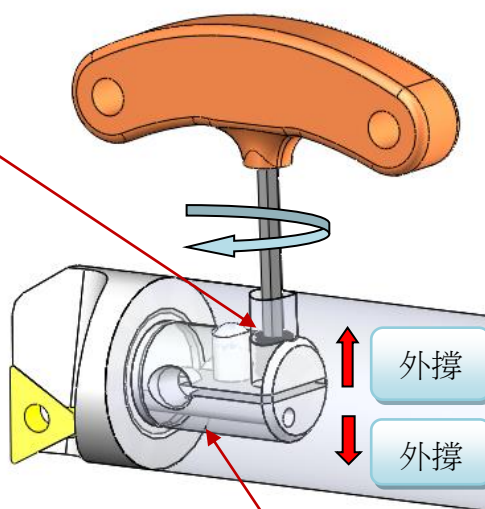

裝配步驟 三.

鎖緊第三孔止水螺絲。

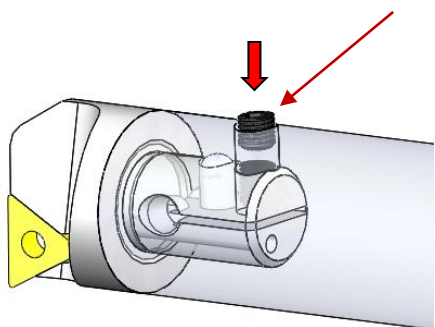

內部圓弧貼合緊密

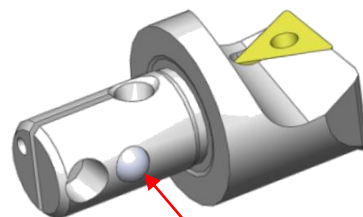

注意安全

注意拆卸時，步驟相反。

模組化刀頭拆裝時，需帶手套，避免刀片割傷手。

SCK系列刀桿表示方法

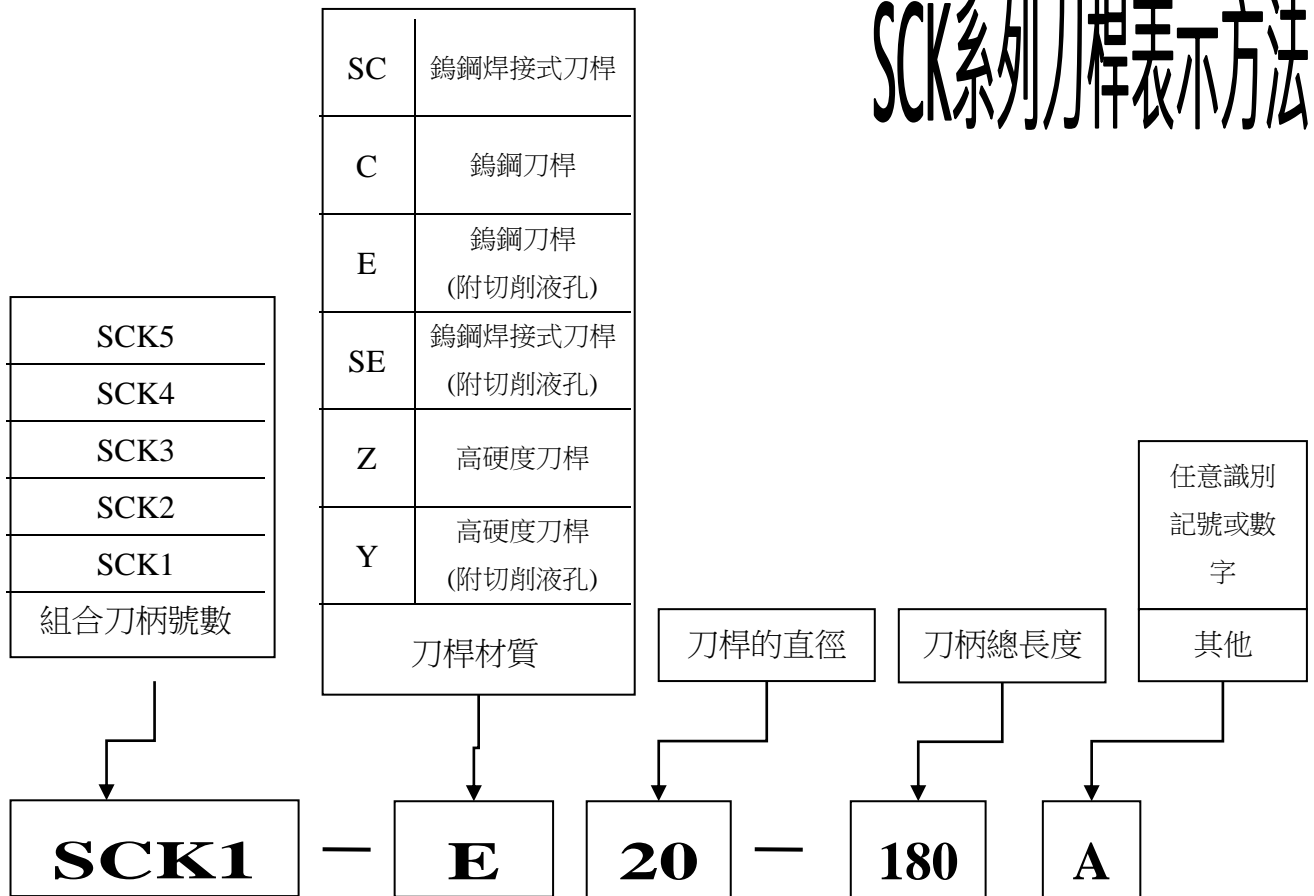

模組化 更換刀頭簡易，重複定位精準

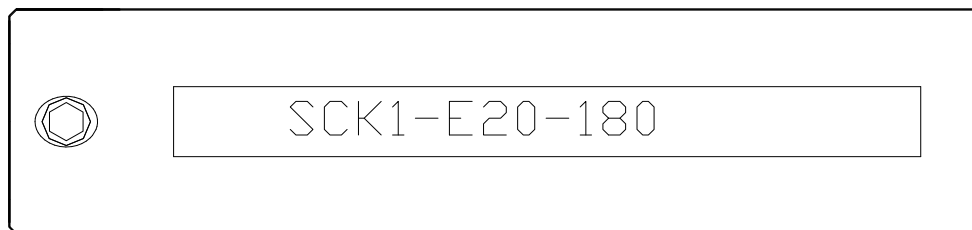

Zy 模組化高硬度高剛性刀桿 Modular Chang High-Hardness Steel Boring Bars

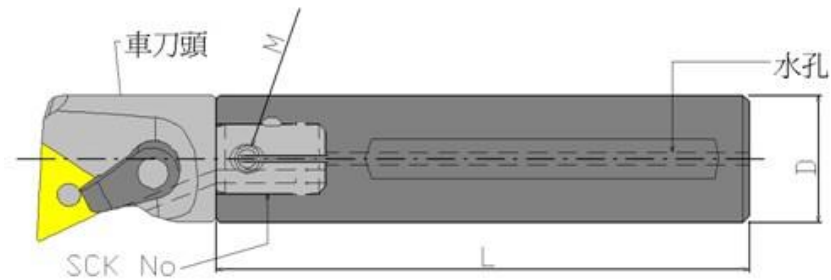

| Stock | 型號 Model No. | 組合刀柄 SCK NO | D | L | 螺絲 Screw | 扳手 Wrench |
|-------|---------------|----------------|----|-----|------------|-----------|
| ● | SCK1-Y20-180L | SCK1 | 20 | 180 | SETM5x8L | P2.5 |
| ● | SCK2-Y25-175L | SCK2 | 25 | 175 | SETM6x8L | P3.0 |
| ● | SCK2-Y25-225L | | 25 | 225 | SETM6x8L | P3.0 |
| ● | SCK3-Y32-170L | SCK3 | 32 | 170 | SETM6x10L | P3.0 |
| ● | SCK3-Y32-220L | | 32 | 220 | SETM6x10L | P3.0 |
| ● | SCK3-Y32-270L | | 32 | 270 | SETM6x10L | P3.0 |
| ● | SCK4-Y40-267L | SCK4 | 40 | 267 | SETM8x16L | P4.0 |
| ● | SCK5-Y50-290L | SCK5 | 50 | 290 | SETM10x16L | P5.0 |
| ● | SCK1-Z20-180L | SCK1 | 20 | 180 | SETM5x8L | P2.5 |
| ● | SCK2-Z25-175L | SCK2 | 25 | 175 | SETM6x8L | P3.0 |

Zy 模組化鎢鋼刀桿 Modular Chang Carbide Steel Boring Bars

| Stock | 型號 Model No. | 組合刀柄 SCK NO | D | L | 螺絲 Screw | 扳手 Wrench |
|-------|---------------|----------------|----|-----|------------|-----------|
| ● | SCK1-E20-180L | SCK1 | 20 | 180 | SETM5x8L | P2.5 |
| ● | SCK1-E20-230L | | 20 | 230 | SETM5x8L | P2.5 |
| ● | SCK2-E25-175L | SCK2 | 25 | 175 | SETM6x8L | P3.0 |
| ● | SCK2-E25-225L | | 25 | 225 | SETM6x8L | P3.0 |
| ● | SCK3-E32-170L | SCK3 | 32 | 170 | SETM6x10L | P3.0 |
| ● | SCK3-E32-220L | | 32 | 220 | SETM6x10L | P3.0 |
| ● | SCK3-E32-270L | | 32 | 270 | SETM6x10L | P3.0 |
| ○ | SCK4-E40-267L | SCK4 | 40 | 267 | SETM8x16L | P4.0 |
| ○ | SCK5-E50-300L | SCK5 | 50 | 300 | SETM10x16L | P5.0 |

●: 庫存 ○: 非標準庫存 (請確認交貨期)

SCK系列車刀頭表示方法

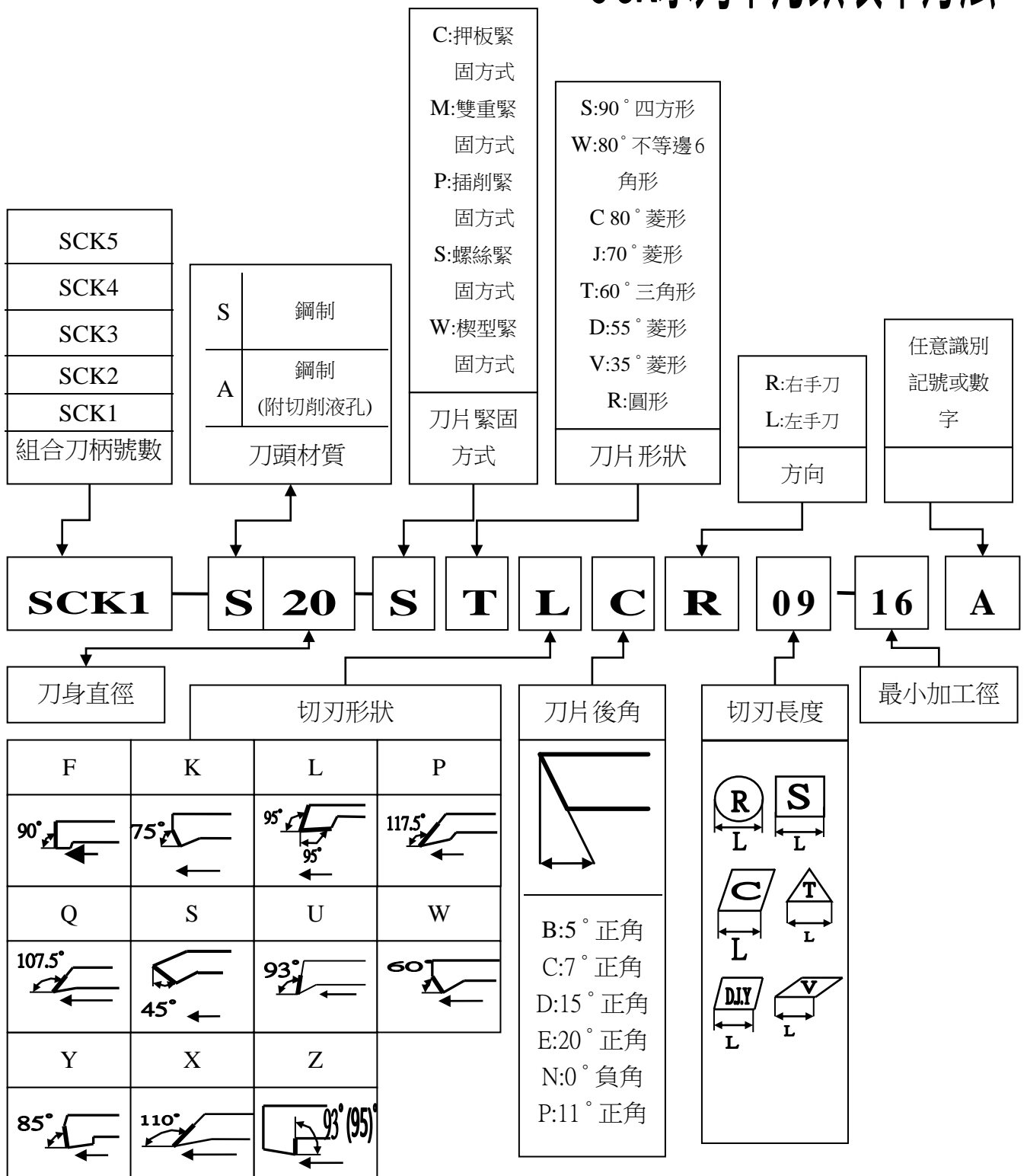

Zy 模組化內徑車刀頭 Modular Internal Head With Coolant

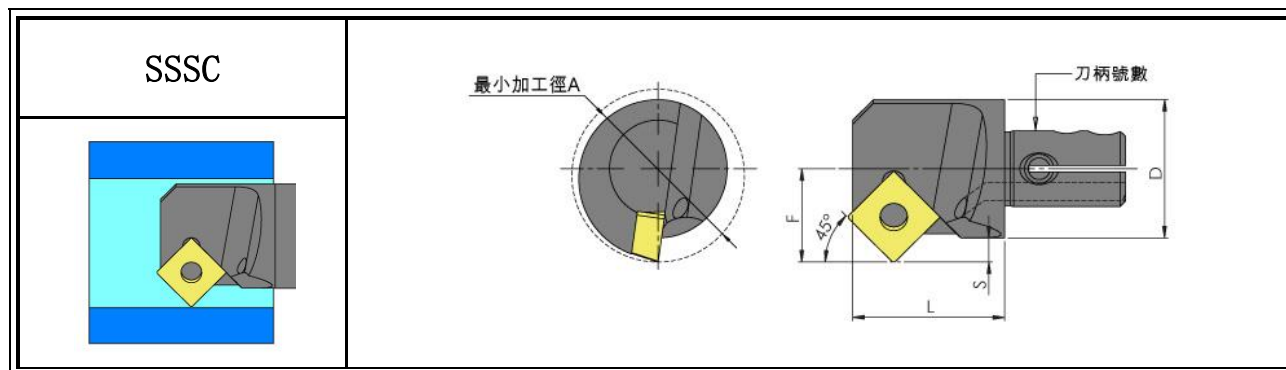

| Stock | 型號 Model No. | 最小加工徑 A | F | D | L | S | 螺絲 Screw | 扳手 Wrench | 刀片 Insert |
|-------|---------------------|---------|------|----|----|-----|------------|-----------|-----------|
| ● | SCK1-A20-SSSCR09-26 | 26 | 13.5 | 20 | 22 | 3.5 | M4x8.8x5.4 | T15 | SC09T3 |
| ○ | SCK2-A25-SSSCR09-31 | 31 | 16 | 25 | 27 | 3.5 | | | |
| ○ | SCK3-A32-SSSCR09-40 | 40 | 19.5 | 32 | 30 | 3.5 | | | |

●:庫存 In Stock ○:非標準庫存(請確認交貨期) Non-standard Stock

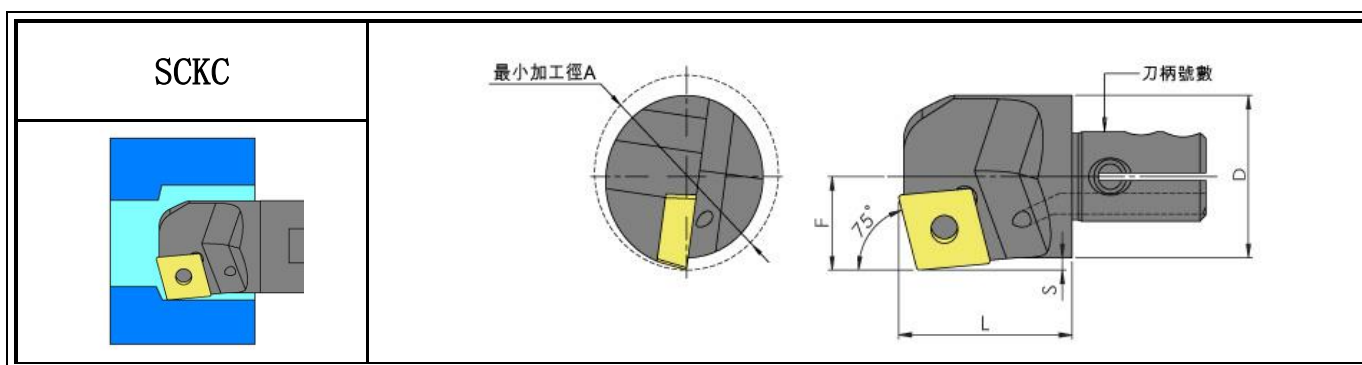

| Stock | 型號 Model No. | 最小加工徑 A | F | D | L | 螺絲 Screw | 扳手 Wrench | 刀片 Insert |
|-------|---------------------|---------|------|----|----|------------|-----------|-----------|
| ○ | SCK0-A16-SCKCR09-20 | 20 | 9 | 16 | 22 | M4x8.8x5.4 | T15 | CC09T3 |
| ● | SCK1-A20-SCKCR09-24 | 24 | 11.5 | 20 | 22 | | | |
| ○ | SCK2-A25-SCKCR09-30 | 30 | 15 | 25 | 25 | | | |
| ○ | SCK3-A32-SCKCR09-38 | 38 | 17.5 | 32 | 30 | | | |

●:庫存 In Stock ○:非標準庫存(請確認交貨期) Non-standard Stock

Zy 模組化內徑車刀頭 Modular Internal Head With Coolant

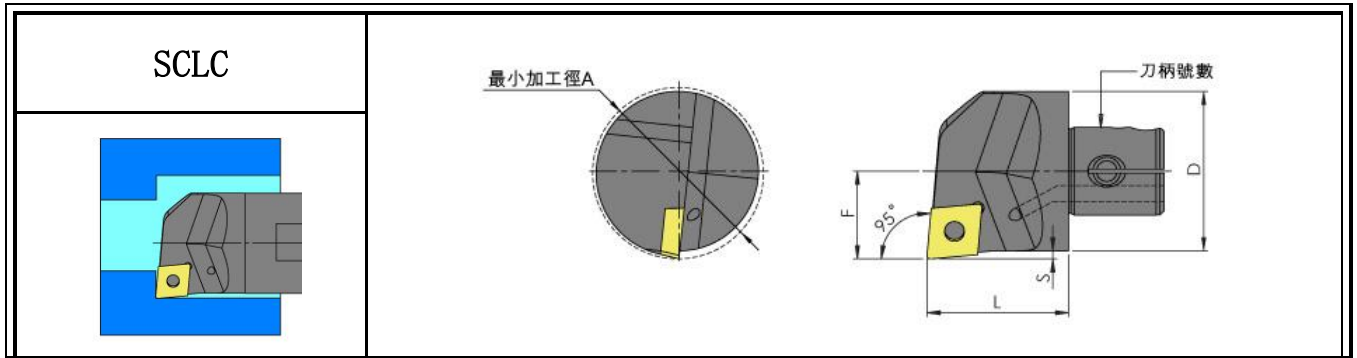

| Stock | 型號 Model No. | 最小加工徑 A | F | D | L | 螺絲 Screw | 扳手 Wrench | 刀片 Insert |
|-------|---------------------|---------|------|----|----|-------------|-----------|-----------|
| ○ | SCK0-A16-SCLCR09-18 | 18 | 9 | 16 | 22 | M4x10.6x5.6 | T15 | CC09T3 |
| ● | SCK1-A20-SCLCR09-22 | 22 | 11 | 20 | 22 | | | |
| ● | SCK1-A20-SCLCR09-24 | 24 | 13 | 20 | 22 | | | |
| ● | SCK2-A25-SCLCR09-28 | 28 | 14.5 | 25 | 25 | | | |
| ● | SCK3-A32-SCLCR09-38 | 38 | 17.5 | 32 | 30 | | | |
| ● | SCK4-A40-SCLCR09-43 | 43 | 21 | 40 | 33 | | | |
| ● | SCK5-A50-SCLCR09-60 | 60 | 30 | 50 | 35 | | | |

●:庫存 In Stock ○:非標準庫存(請確認交貨期) Non-standard Stock

Zy 模組化內徑車刀頭 Modular Internal Head With Coolant

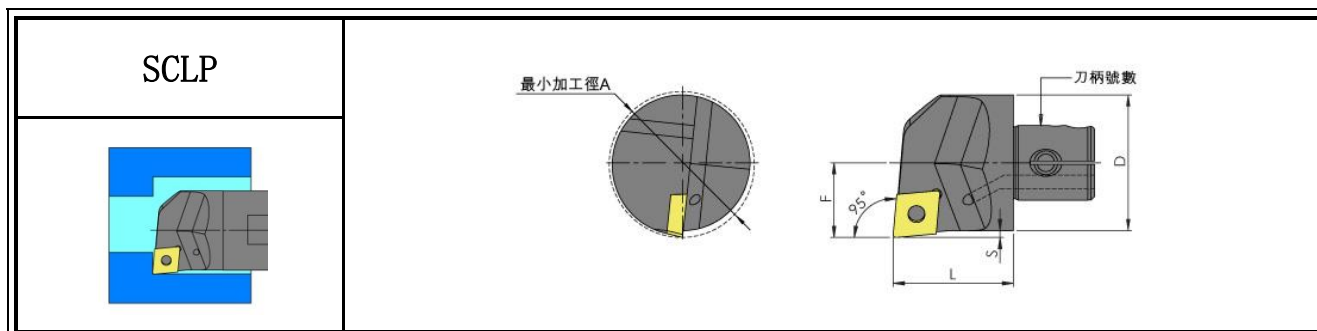

| Stock | 型號 Model No. | 最小加工徑 A | F | D | L | 螺絲 Screw | 扳手 Wrench | 刀片 Insert |
|-------|---------------------|---------|------|----|----|------------|-----------|-----------|
| ○ | SCK0-A16-SCLPR09-18 | 18 | 9 | 16 | 22 | M4x8.8x5.4 | T15 | CP0903 |
| ● | SCK1-A20-SCLPR09-22 | 22 | 11 | 20 | 22 | | | |
| ● | SCK2-A25-SCLPR09-28 | 28 | 14 | 25 | 25 | | | |
| ○ | SCK3-A32-SCLPR09-35 | 35 | 17.5 | 32 | 24 | | | |

●:庫存 In Stock ○:非標準庫存(請確認交貨期) Non-standard Stock

Zy 模組化內徑車刀頭 Modular Internal Head With Coolant

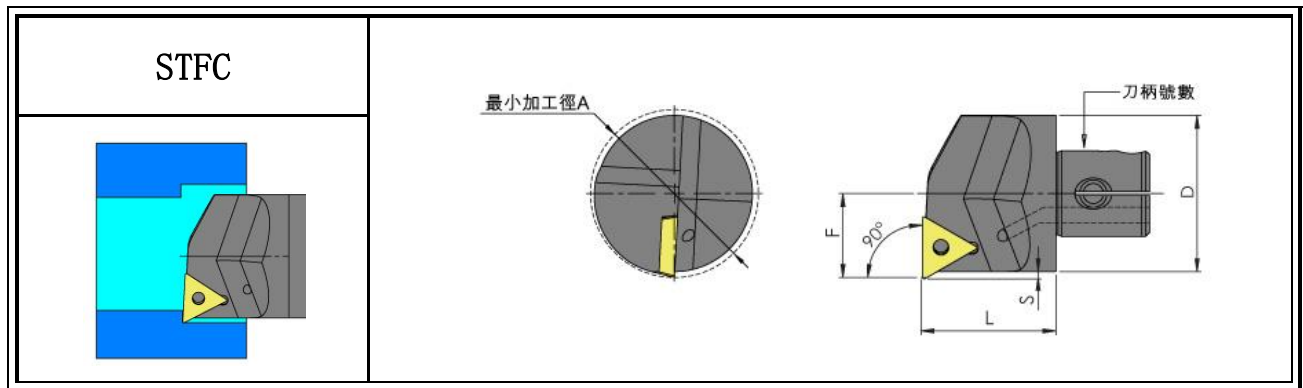

| Stock | 型號 Model No. | 最小加工徑 A | F | D | L | 螺絲 Screw | 扳手 Wrench | 刀片 Insert |
|-------|-----------------------|---------|------|----|----|--------------|-----------|-----------|
| ○ | SCK0-A16-STFCR11-18 | 18 | 9.5 | 16 | 22 | M2.5x6.0x3.6 | T8 | TC1102 |
| ● | SCK1-A20-STFCR11-22 | 22 | 11 | 20 | 22 | | | |
| ● | SCK2-A25-STFCR11-28 | 28 | 14 | 25 | 25 | | | |
| ● | SCK1-A20-STFCR16T3-22 | 22 | 11.5 | 20 | 22 | M4x8.8x5.4 | T15 | TC16T3 |
| ○ | SCK2-A25-STFCR16T3-28 | 28 | 14 | 25 | 27 | | | |
| ● | SCK3-A32-STFCR16T3-35 | 35 | 17.5 | 32 | 30 | | | |
| ● | SCK4-A40-STFCR16T3-43 | 43 | 21.5 | 40 | 33 | | | |
| ○ | SCK5-A50-STFCR16T3-53 | 53 | 27 | 50 | 35 | | | |

●:庫存 In Stock ○:非標準庫存(請確認交貨期) Non-standard Stock

Zy 模組化內徑車刀頭 Modular Internal Head With Coolant

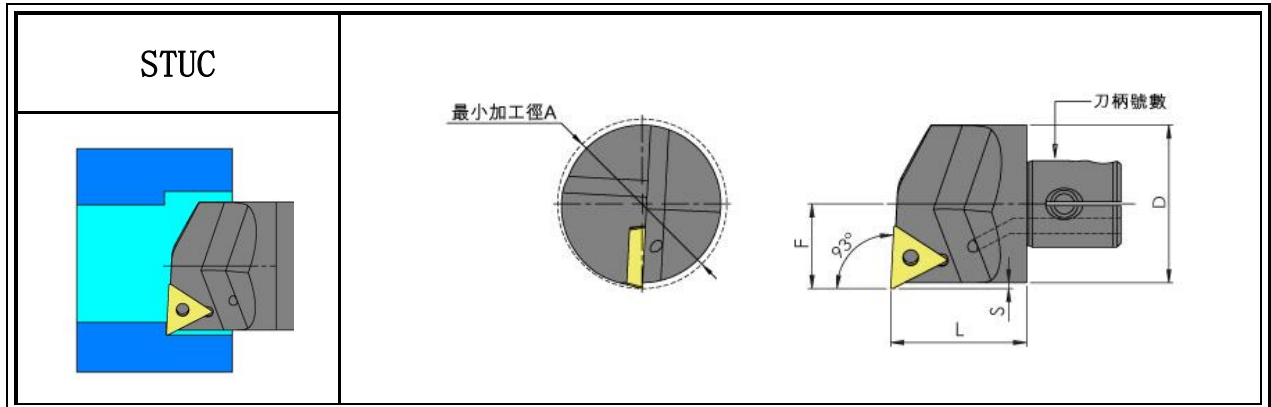

| Stock | 型號 Model No. | 最小加工徑 A | F | D | L | 螺絲 Screw | 扳手 Wrench | 刀片 Insert |
|-------|-----------------------|---------|------|----|----|--------------|-----------|-----------|
| ○ | SCK0-A16-STUCR11-18 | 18 | 9 | 16 | 22 | M2.5x6.0x3.6 | T8 | TC1102 |
| ● | SCK1-A20-STUCR11-22 | 22 | 11 | 20 | 22 | | | |
| ● | SCK2-A25-STUCR11-28 | 28 | 14 | 25 | 25 | | | |
| ● | SCK1-A20-STUCR16T3-22 | 22 | 11 | 20 | 22 | M4x8.8x5.4 | T15 | TC16T3 |
| ● | SCK2-A25-STUCR16T3-28 | 28 | 14 | 25 | 27 | | | |
| ● | SCK3-A32-STUCR16T3-38 | 38 | 17.5 | 32 | 30 | | | |
| ○ | SCK4-A40-STUCR16T3-50 | 50 | 21.5 | 40 | 33 | | | |
| ○ | SCK5-A50-STUCR16T3-60 | 60 | 26.5 | 50 | 35 | | | |

●:庫存 In Stock ○:非標準庫存(請確認交貨期) Non-standard Stock

Zy 模組化內徑車刀頭 Modular Internal Head With Coolant

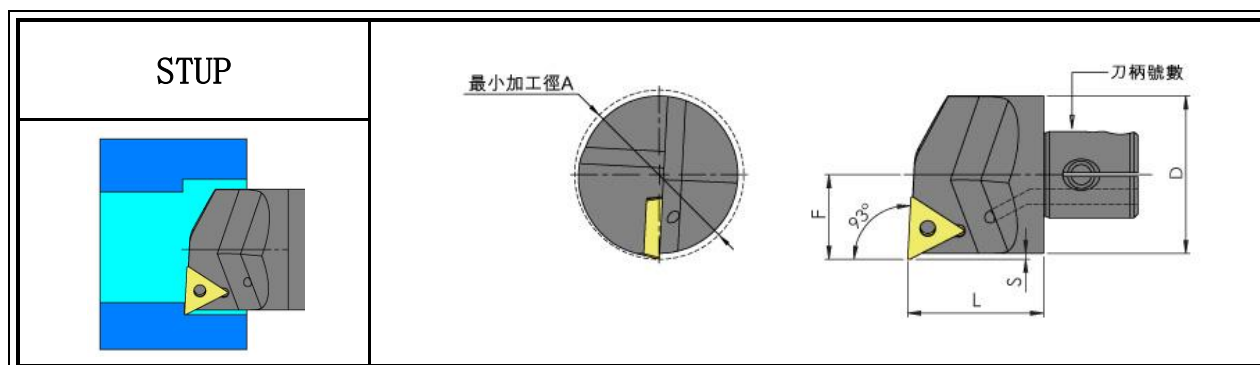

| Stock | 型號 Model No. | 最小加工徑 A | F | D | L | 螺絲 Screw | 板手 Wrench | 刀片 Insert |
|-------|-----------------------|---------|------|----|------|------------|-----------|-----------|
| ● | SCK1-A20-STUPR11-22 | 22 | 11.5 | 20 | 22 | M3x7.8x4.1 | T9 | TP1103 |
| ● | SCK2-A25-STUPR11-30 | 30 | 15 | 25 | 25 | | | |
| ● | SCK3-A32-STUPR11-36 | 36 | 18.5 | 32 | 30 | | | |
| ● | SCK1-A20-STUPR1603-25 | 25 | 13 | 20 | 25.5 | M4x8.8x5.4 | T15 | TP1603 |
| ● | SCK2-A25-STUPR1603-28 | 28 | 14 | 25 | 27 | | | |
| ● | SCK3-A32-STUPR1603-38 | 38 | 17.5 | 32 | 30 | | | |
| ○ | SCK4-A40-STUPR1603-43 | 43 | 21.5 | 40 | 33 | | | |
| ○ | SCK5-A50-STUPR1603-60 | 60 | 26.5 | 50 | 35 | | | |
| ● | SCK1-A20-STUPR16T3-25 | 25 | 13 | 20 | 25.5 | M4x8.8-5.4 | T15 | TP16T3 |
| ● | SCK2-A25-STUPR16T3-28 | 28 | 14 | 25 | 27 | | | |
| ○ | SCK3-A32-STUPR16T3-35 | 38 | 17.5 | 32 | 30 | | | |
| ○ | SCK4-A40-STUPR16T3-50 | 50 | 21.5 | 40 | 33 | | | |
| ○ | SCK5-A50-STUPR16T3-53 | 53 | 27 | 50 | 35 | | | |
| ● | SCK1-A20-STUPR1604-25 | 25 | 13 | 20 | 25.5 | M4x8.8x5.6 | T15 | TP1604 |
| ● | SCK2-A25-STUPR1604-28 | 28 | 14 | 25 | 27 | | | |
| ● | SCK3-A32-STUPR1604-38 | 38 | 17.5 | 32 | 30 | | | |
| ● | SCK4-A40-STUPR1604-43 | 43 | 21.5 | 40 | 33 | | | |
| ○ | SCK5-A50-STUPR1604-60 | 60 | 26.5 | 50 | 35 | | | |

●:庫存 In Stock ○:非標準庫存(請確認交貨期) Non-standard Stock

Zy 模組化內徑車刀頭 Modular Internal Head With Coolant

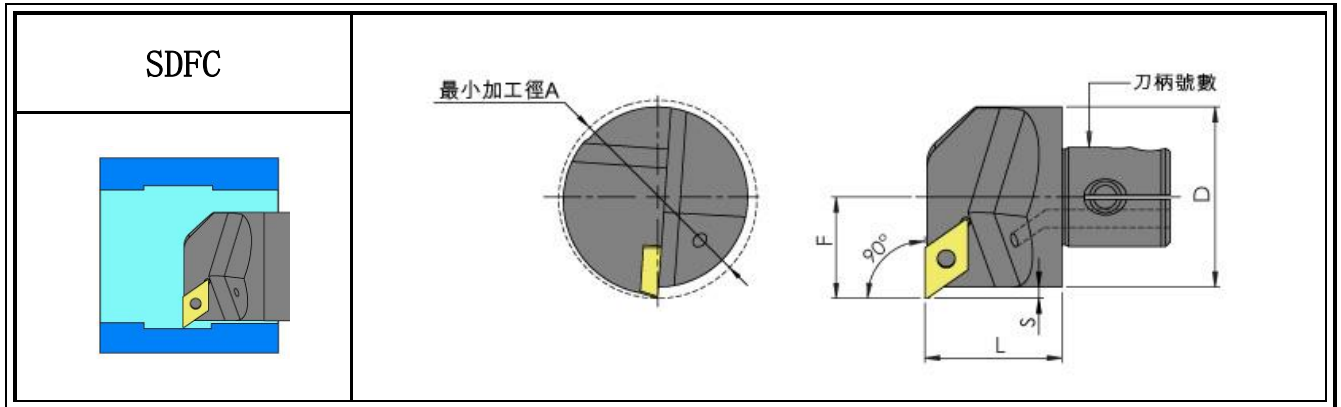

| Stock | 型號 Model No. | 最小加工徑 A | F | D | L | S | 螺絲 Screw | 扳手 Wrench | 刀片 Insert |
|-------|---------------------|---------|------|----|----|-----|--------------|-----------|-----------|
| ● | SCK1-A20-SDFCR11-24 | 25 | 13 | 20 | 22 | 3 | M4x8. 8x5. 4 | T15 | DC11T3 |
| ● | SCK2-A25-SDFCR11-32 | 32 | 17 | 25 | 27 | 3 | | | |
| ● | SCK3-A32-SDFCR11-36 | 36 | 18 | 32 | 27 | 2 | | | |
| ● | SCK4-A40-SDFCR11-44 | 44 | 22.5 | 40 | 27 | 2.5 | | | |

●:庫存 In Stock ○:非標準庫存(請確認交貨期) Non-standard Stock

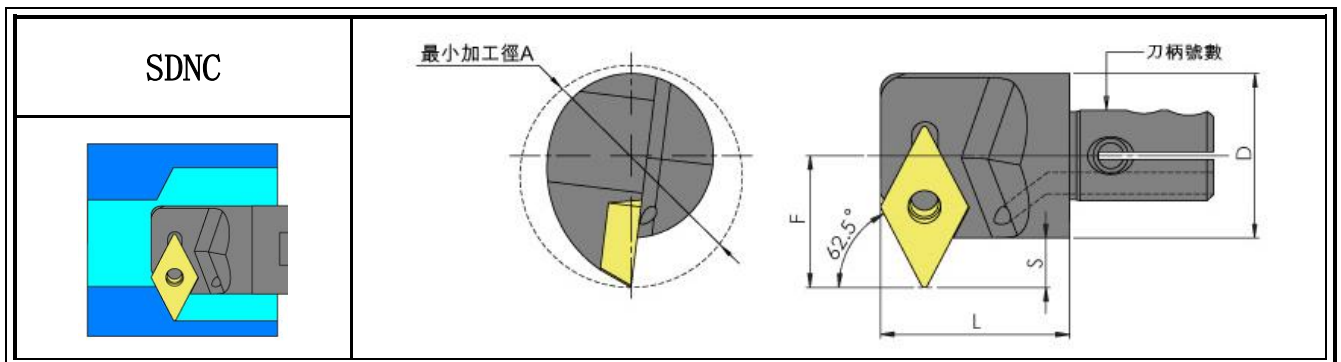

| Stock | 型號 Model No. | 最小加工徑 A | F | D | L | S | 螺絲 Screw | 扳手 Wrench | 刀片 Insert |
|-------|---------------------|---------|------|----|----|-----|--------------|-----------|-----------|
| ● | SCK1-A20-SDNCR11-27 | 27 | 16 | 20 | 22 | 6 | M4x8. 8x5. 4 | T15 | DC11T3 |
| ○ | SCK2-A25-SDNCR11-32 | 32 | 18 | 25 | 27 | 5.5 | | | |
| ● | SCK3-A32-SDNCR11-38 | 38 | 20.5 | 32 | 30 | 4.5 | | | |

●:庫存 In Stock ○:非標準庫存(請確認交貨期) Non-standard Stock

Zy 模組化內徑車刀頭 Modular Internal Head With Coolant

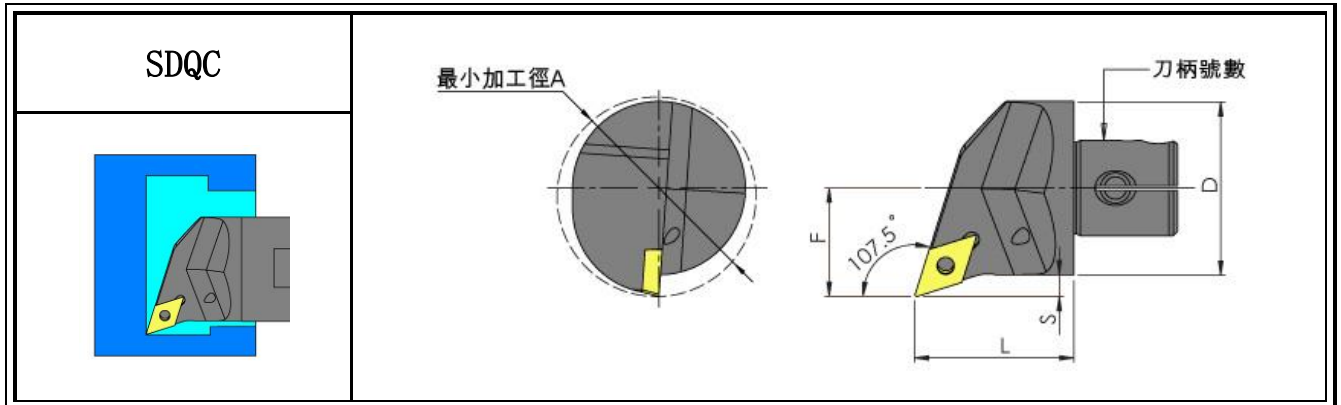

| Stock | 型號 Model No. | 最小加工徑 A | F | D | L | S | 螺絲 Screw | 板手 Wrench | 刀片 Insert |
|-------|---------------------|---------|----|----|----|---|--------------|-----------|-----------|
| ● | SCK1-A20-SDQCR11-25 | 25 | 13 | 20 | 22 | 3 | M4x8. 8x5. 4 | T15 | DC11T3 |
| ● | SCK2-A25-SDQCR11-32 | 32 | 17 | 25 | 27 | 3 | | | |
| ● | SCK3-A32-SDQCR11-40 | 40 | 20 | 32 | 30 | 4 | | | |
| ● | SCK4-A40-SDQCR11-46 | 46 | 25 | 40 | 33 | 5 | | | |
| ● | SCK5-A50-SDQCR11-56 | 56 | 30 | 50 | 35 | 5 | | | |

●:庫存 In Stock ○:非標準庫存(請確認交貨期) Non-standard Stock

Zy 模組化內徑車刀頭 Modular Internal Head With Coolant

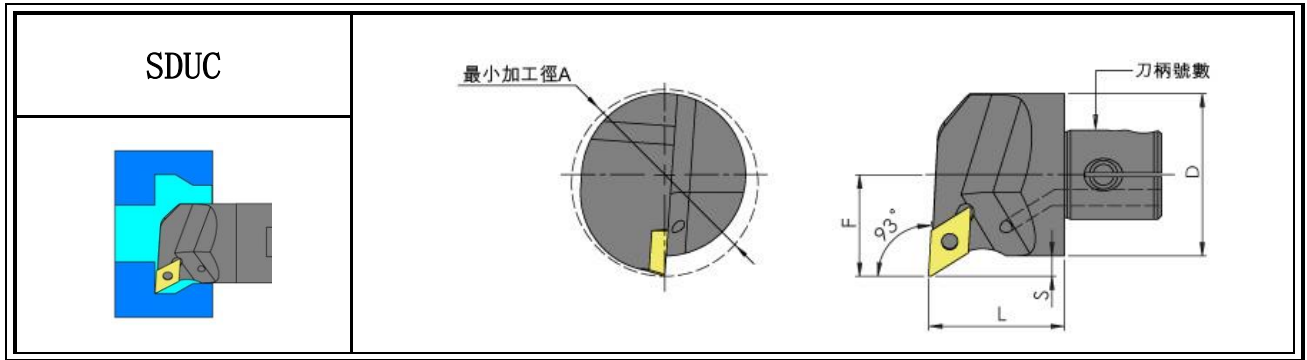

| Stock | 型號 Model No. | 最小加工徑 A | F | D | L | S | 螺絲 Screw | 扳手 Wrench | 刀片 Insert |
|-------|---------------------|---------|------|----|----|-----|--------------|-----------|-----------|
| ● | SCK1-A20-SDUCR07-25 | 25 | 13 | 20 | 22 | 3 | M2.5x6.0x3.6 | T8 | DC0702 |
| ● | SCK1-A20-SDUCR11-23 | 23 | 12.5 | 20 | 22 | 2.5 | M4x8.8x5.4 | T15 | DC11T3 |
| ● | SCK1-A20-SDUCR11-25 | 25 | 13 | 20 | 22 | 3 | | | |
| ● | SCK2-A25-SDUCR11-32 | 32 | 17 | 25 | 25 | 4.5 | | | |
| ● | SCK3-A32-SDUCR11-37 | 37 | 20 | 32 | 30 | 4 | | | |
| ● | SCK4-A40-SDUCR11-46 | 46 | 25 | 40 | 33 | 5 | | | |
| ● | SCK5-A50-SDUCR11-56 | 56 | 30 | 50 | 35 | 5 | | | |

●:庫存 In Stock ○:非標準庫存(請確認交貨期) Non-standard Stock

Zy 模組化內徑車刀頭 Modular Internal Head With Coolant

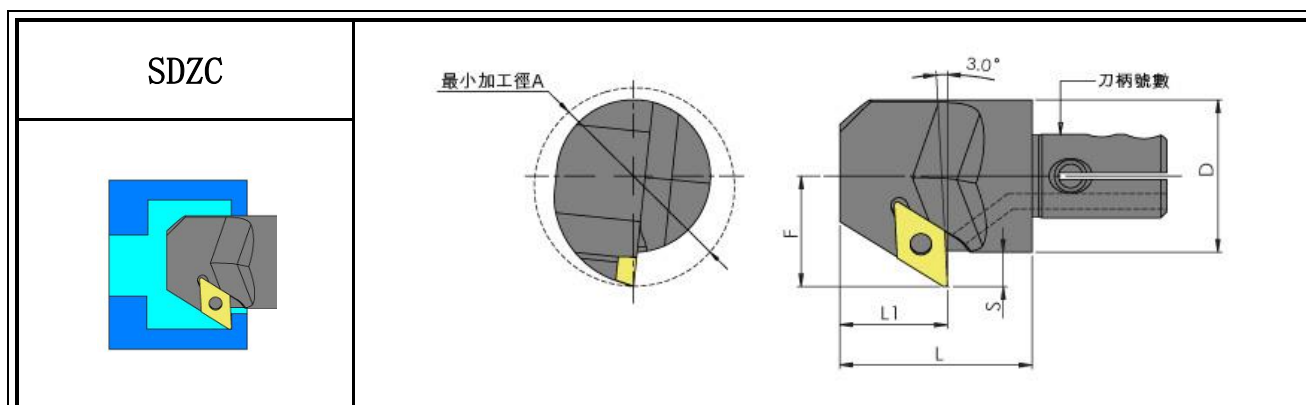

| Stock | 型號 Model No. | 最小加工徑 A | F | D | L | L1 | S | 螺絲 Screw | 扳手 Wrench | 刀片 Insert |
|-------|---------------------|---------|------|----|----|----|-----|------------|-----------|-----------|
| ● | SCK1-A20-SDZCR11-26 | 26 | 15.5 | 20 | 29 | 18 | 5.5 | M4x8.8x5.4 | T15 | DC11T3 |
| ● | SCK1-A20-SDZCR11-28 | 28 | 17 | 20 | 29 | 18 | 7.0 | | | |
| ● | SCK2-A25-SDZCR11-33 | 33 | 18 | 25 | 34 | 18 | 5.5 | | | |
| ● | SCK3-A32-SDZCR11-40 | 40 | 21.5 | 32 | 35 | 18 | 5.5 | | | |

●:庫存 In Stock ○:非標準庫存(請確認交貨期) Non-standard Stock

Zy 模組化內徑車刀頭 Modular Internal Head With Coolant

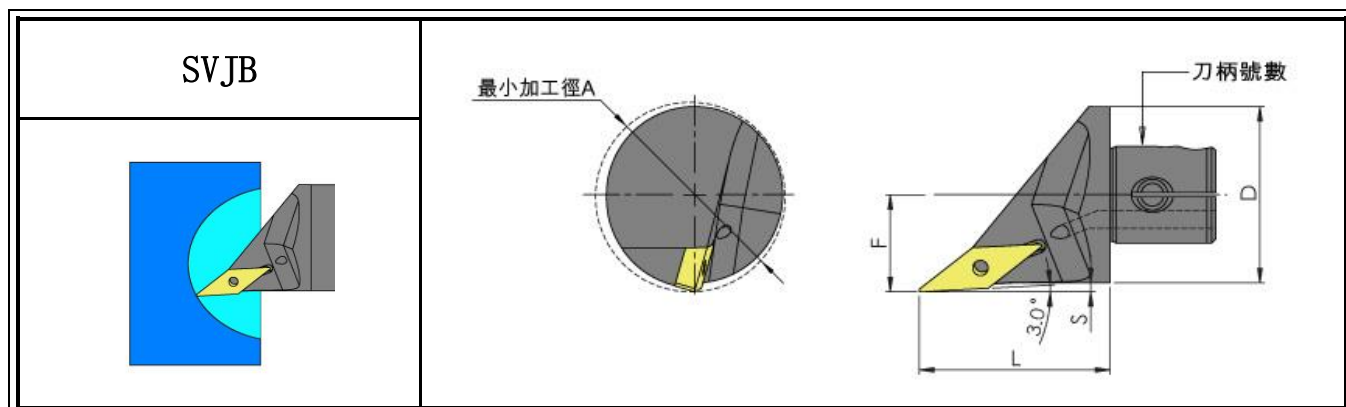

| Stock | 型號 Model No. | 最小加工徑 A | F | D | L | S | 螺絲 Screw | 扳手 Wrench | 刀片 Insert |
|-------|---------------------|---------|------|----|----|-----|---------------|-----------|-----------|
| ● | SCK1-A20-SVJBR11-22 | 22 | 11 | 20 | 29 | 1 | M2.5x6.0x3.6 | T8 | VB1103 |
| ● | SCK2-A25-SVJBR11-28 | 28 | 14 | 25 | 32 | 1.5 | | | |
| ● | SCK3-A32-SVJBR16-35 | 35 | 17.5 | 32 | 42 | 1.5 | M3.5x12.0x5.4 | T15 | VB1604 |
| ● | SCK4-A40-SVJBR16-43 | 43 | 22 | 40 | 42 | 2 | | | |

●:庫存 In Stock ○:非標準庫存(請確認交貨期) Non-standard Stock

Zy 模組化內徑車刀頭 Modular Internal Head With Coolant

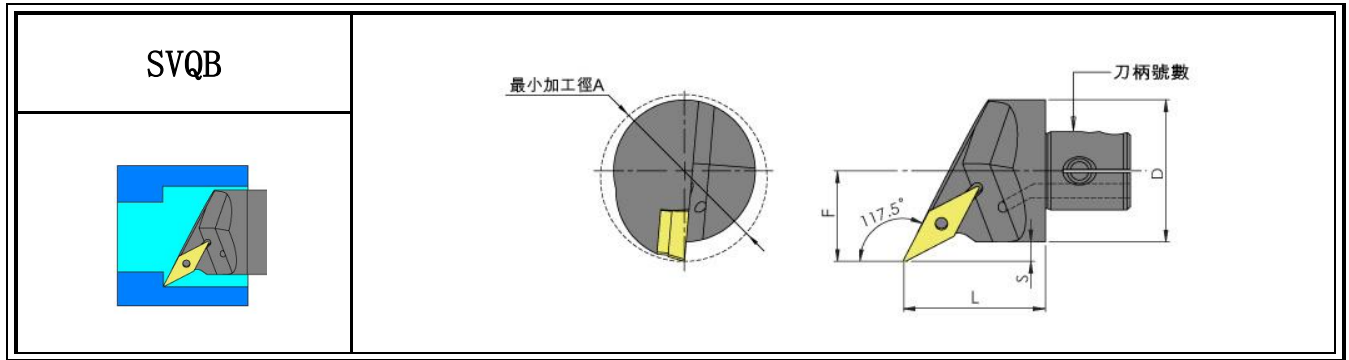

| Stock | 型號 Model No. | 最小加工徑 A | F | D | L | S | 墊片 Shim | 螺絲 Screw | 板手 Wrench | 刀片 Insert |
|-------|---------------------|---------|----|----|------|-----|---------|---------------|-----------|-----------|
| ● | SCK1-A20-SVQBR11-25 | 25 | 14 | 20 | 25.5 | 4 | - | M2.5x6.0x3.6 | T8 | VB1103 |
| ○ | SCK2-A25-SVQBR11-32 | 32 | 18 | 25 | 27 | 5.5 | - | | | |
| ○ | SCK1-A20-SVQBR16-25 | 25 | 14 | 20 | 25.5 | 4 | - | M3.5x12.0x5.4 | T15 | VB1604 |
| ○ | SCK2-A25-SVQBR16-32 | 32 | 18 | 25 | 27 | 5.5 | - | | | |
| ● | SCK3-A32-SVQBR16-37 | 37 | 20 | 32 | 32 | 4 | - | | | |
| ● | SCK4-A40-SVQBR16-47 | 47 | 26 | 40 | 42 | 6 | VSS322 | M3.5x11.4x5.7 | | |
| ● | SCK5-A32-SVQBR16-58 | 58 | 32 | 50 | 45 | 7 | | | | |

●:庫存 In Stock ○:非標準庫存(請確認交貨期) Non-standard Stock

Zy 模組化內徑車刀頭 Modular Internal Head With Coolant

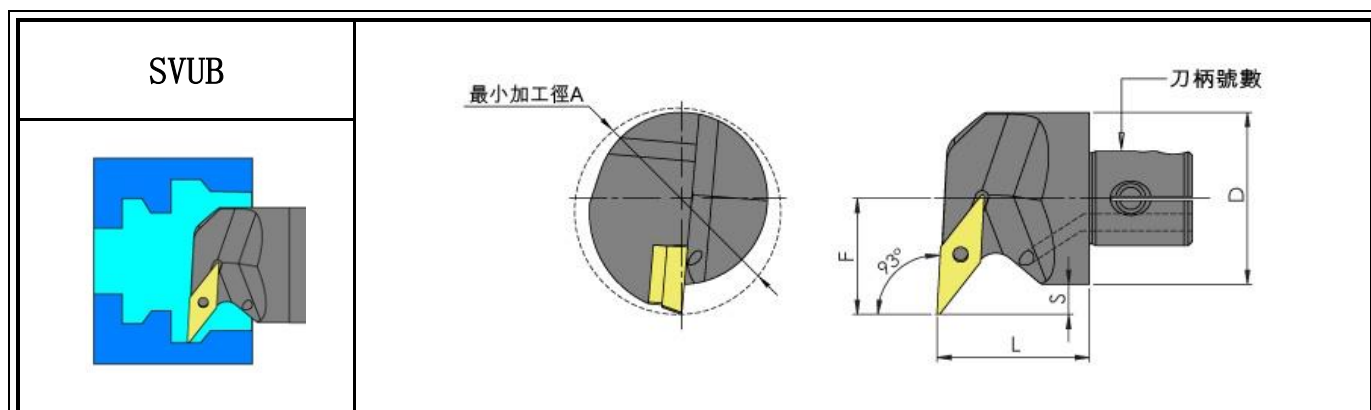

| Stock | 型號 Model No. | 最小加工徑 A | F | D | L | S | 墊片 Shim | 螺絲 Screw | 板手 Wrench | 刀片 Insert |
|-------|---------------------|---------|----|----|----|-----|---------|---------------|-----------|-----------|
| ● | SCK1-A20-SVUBR11-27 | 27 | 15 | 20 | 22 | 5 | - | M2.5x6.0x3.6 | T8 | VB1103 |
| ● | SCK1-A20-SVUBR16-31 | 31 | 19 | 20 | 27 | 9 | - | M3.5x12.0x5.4 | T15 | VB1604 |
| ● | SCK2-A25-SVUBR16-33 | 33 | 18 | 25 | 27 | 5.5 | - | | | |
| ● | SCK3-A32-SVUBR16-40 | 40 | 22 | 32 | 30 | 6 | - | | | |
| ● | SCK3-A32-SVUBR16-40 | 40 | 23 | 32 | 30 | 7 | VSS322 | M3.5x11.4x5.7 | T15 | VB1604 |
| ● | SCK4-A40-SVUBR16-48 | 48 | 27 | 40 | 35 | 7 | | | | |
| ● | SCK4-A40-SVUBR16-51 | 51 | 30 | 40 | 35 | 10 | | | | |
| ● | SCK5-A50-SVUBR16-58 | 58 | 32 | 50 | 42 | 7 | | | | |

●:庫存 In Stock ○:非標準庫存(請確認交貨期) Non-standard Stock

Zy 模組化內徑車刀頭 Modular Internal Head With Coolant

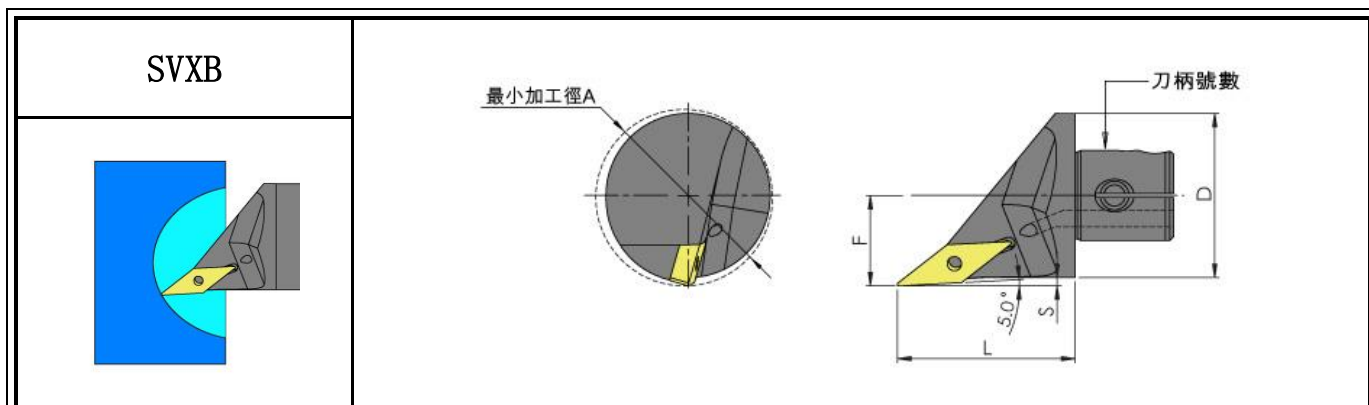

| Stock | 型號 Model No. | 最小加工徑 A | F | D | L | S | 螺絲 Screw | 扳手 Wrench | 刀片 Insert |
|-------|---------------------|---------|----|----|----|---|---------------|-----------|-----------|
| ● | SCK3-A32-SVXBR16-35 | 35 | 18 | 32 | 35 | 2 | M3.5x12.0x5.4 | T15 | VB1604 |
| ● | SCK4-A40-SVXBR16-43 | 43 | 25 | 40 | 36 | 5 | | | |
| ● | SCK5-A50-SVXBR16-53 | 53 | 27 | 50 | 45 | 2 | | | |

●:庫存 In Stock ○:非標準庫存(請確認交貨期) Non-standard Stock

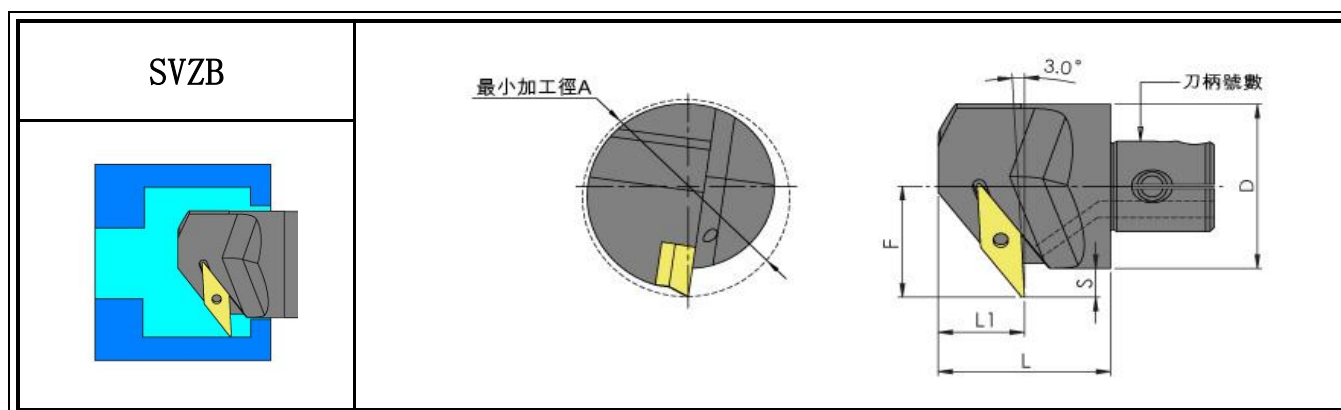

| Stock | 型號 Model No. | 最小加工徑 A | F | D | L | L1 | S | 螺絲 Screw | 扳手 Wrench | 刀片 Insert |
|-------|---------------------|---------|----|----|----|----|-----|---------------|-----------|-----------|
| ● | SCK1-A20-SVZBR11-25 | 25 | 14 | 20 | 25 | 12 | 4 | M2.5x6.0x3.6 | T8 | VB1103 |
| ○ | SCK1-A20-SVZBR16-29 | 29 | 18 | 20 | 31 | 20 | 8 | M3.5x12.0x5.4 | T15 | VB1604 |
| ○ | SCK2-A25-SVZBR16-35 | 35 | 21 | 25 | 36 | 20 | 8.5 | | | |
| ○ | SCK3-A32-SVZBR16-42 | 42 | 23 | 32 | 41 | 19 | 7 | | | |

●:庫存 In Stock ○:非標準庫存(請確認交貨期) Non-standard Stock

Zy 模組化內徑車刀頭 Modular Internal Head With Coolant

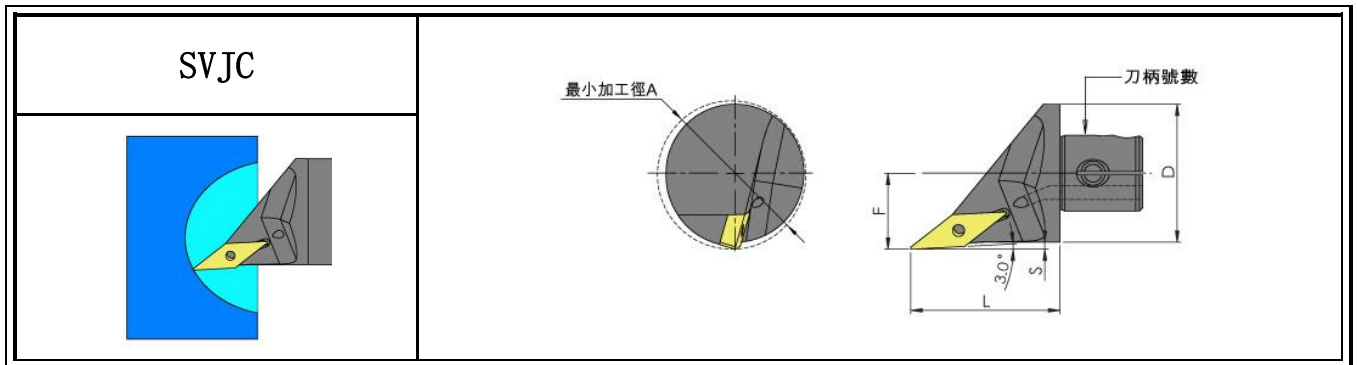

| Stock | 型號 Model No. | 最小加工徑 A | F | D | L | 螺絲 Screw | 板手 Wrench | 刀片 Insert |
|-------|---------------------|---------|------|----|----|---------------|-----------|-----------|
| ● | SCK1-A20-SVJCR11-22 | 22 | 11 | 20 | 29 | M2.5x6.0x3.6 | T8 | VC1103 |
| ● | SCK1-A20-SVJCR16-23 | 23 | 11.5 | 20 | 33 | M3.5x12.0x5.4 | T15 | VC1604 |
| ● | SCK2-A25-SVJCR16-28 | 28 | 14 | 25 | 35 | | | |
| ● | SCK3-A32-SVJCR16-35 | 35 | 17.5 | 32 | 39 | | | |

●:庫存 In Stock ○:非標準庫存(請確認交貨期) Non-standard Stock

Zy 模組化內徑車刀頭 Modular Internal Head With Coolant

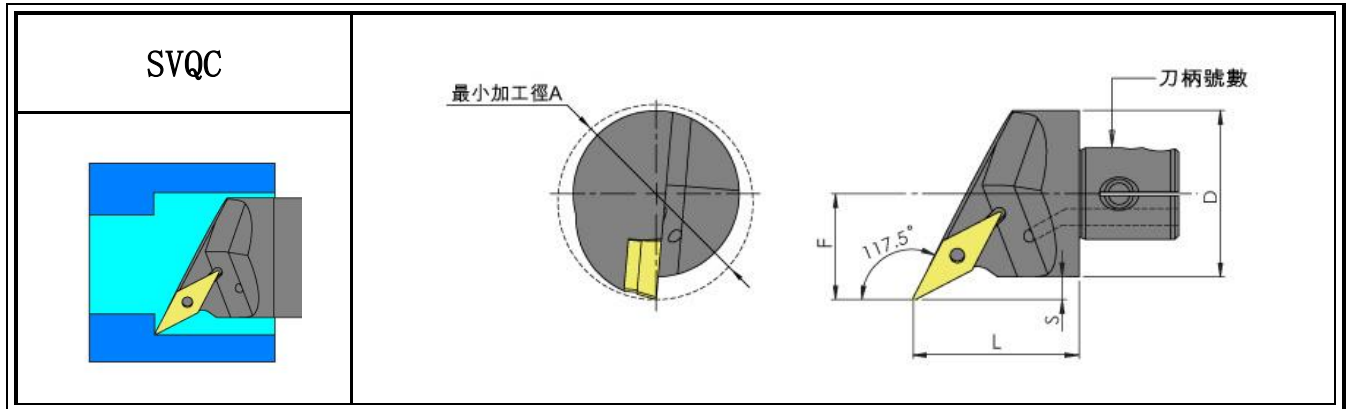

| Stock | 型號 Model No. | 最小加工徑 A | F | D | L | S | 墊片 Shim | 螺絲 Screw | 板手 Wrench | 刀片 Insert |
|-------|---------------------|---------|----|----|------|-----|---------|---------------|-----------|-----------|
| ● | SCK1-A20-SVQCR11-25 | 25 | 14 | 20 | 25.5 | 4 | - | M2.5x6.0x3.6 | T8 | VC1103 |
| ● | SCK2-A25-SVQCR11-32 | 32 | 18 | 25 | 27 | 5.5 | - | | | |
| ○ | SCK1-A20-SVQCR16-25 | 25 | 14 | 20 | 25.5 | 4 | - | M3.5x12.0x5.4 | T15 | VC1604 |
| ● | SCK2-A25-SVQCR16-32 | 32 | 18 | 25 | 27 | 5.5 | - | | | |
| ● | SCK3-A32-SVQCR16-37 | 37 | 20 | 32 | 32 | 4 | - | | | |
| ● | SCK4-A40-SVQCR16-47 | 47 | 26 | 40 | 42 | 6 | VSS322 | M3.5x11.4x5.7 | | |
| ● | SCK5-A32-SVQCR16-58 | 58 | 32 | 50 | 45 | 7 | | | | |

●:庫存 In Stock ○:非標準庫存(請確認交貨期) Non-standard Stock

Zy 模組化內徑車刀頭 Modular Internal Head With Coolant

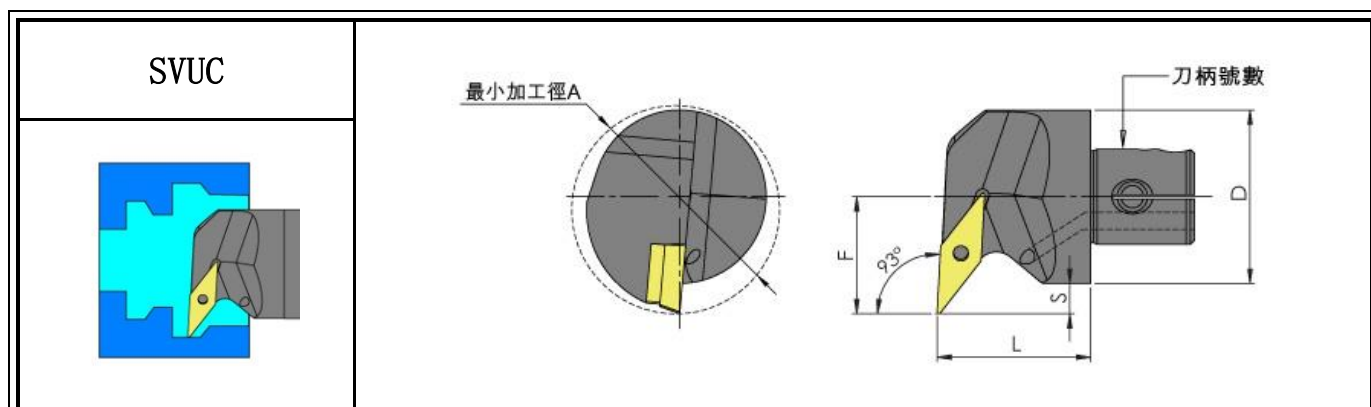

| Stock | 型號 Model No. | 最小加工徑 A | F | D | L | S | 墊片 Shim | 螺絲 Clamp Screw | 板手 Wrench | 刀片 Insert |
|-------|---------------------|---------|----|----|----|-----|---------|----------------|-----------|-----------|
| ● | SCK1-A20-SVUCR11-27 | 27 | 15 | 20 | 22 | 5 | - | M2.5x6.0x3.6 | T8 | VC1103 |
| ● | SCK2-A25-SVUCR11-31 | 31 | 17 | 25 | 25 | 4.5 | - | | | |
| ● | SCK1-A20-SVUCR16-31 | 31 | 19 | 20 | 27 | 9 | - | M3.5x12.0x5.4 | T15 | VC1604 |
| ● | SCK2-A25-SVUCR16-33 | 33 | 18 | 25 | 27 | 5.5 | - | | | |
| ● | SCK2-A25-SVUCR16-35 | 35 | 20 | 25 | 27 | 7.5 | - | | | |
| ● | SCK3-A32-SVUCR16-40 | 40 | 22 | 32 | 30 | 6 | - | | | |
| ● | SCK4-A40-SVUCR16-48 | 48 | 27 | 40 | 33 | 7 | - | | | |
| ● | SCK5-A50-SVUCR16-58 | 58 | 32 | 50 | 42 | 7 | VSS322 | M3.5x11.4x5.7 | | |

●:庫存 In Stock ○:非標準庫存(請確認交貨期) Non-standard Stock

Zy 模組化內徑車刀頭 Modular Internal Head With Coolant

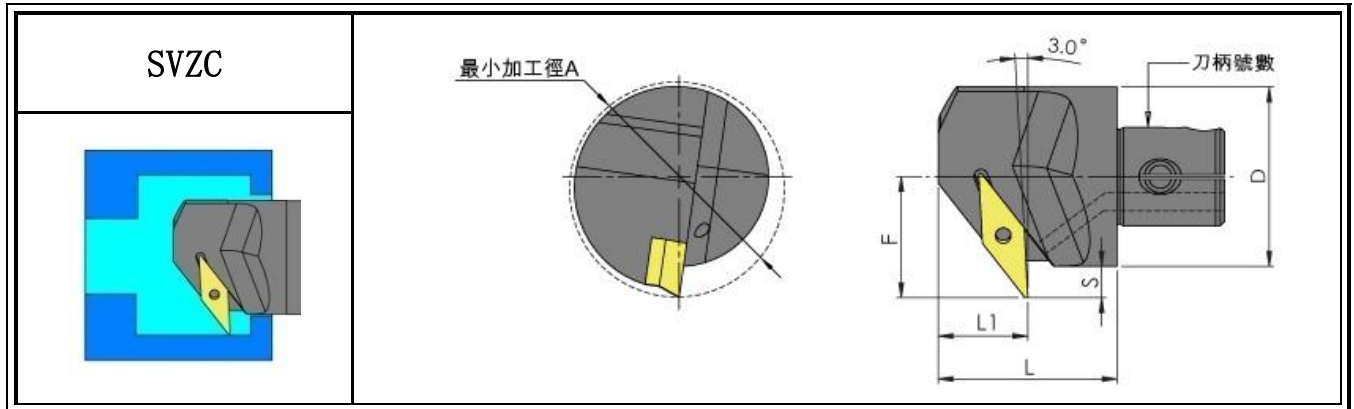

| Stock | 型號 Model No. | 最小加工徑 A | F | D | L | L1 | S | 墊片 Shim | 螺絲 Screw | 板手 Wrench | 刀片 Insert |
|-------|---------------------|---------|------|----|----|----|---|---------|---------------|-----------|-----------|
| ● | SCK2-A25-SVZCR16-34 | 34 | 19.5 | 25 | 36 | 20 | 7 | - | M3.5x11.4x5.7 | T15 | VC1604 |
| ● | SCK3-A32-SVZCR16-40 | 40 | 23 | 32 | 41 | 19 | 7 | VSS322 | M3.5x12.0x5.4 | | |
| ● | SCK4-A40-SVZCR16-48 | 48 | 27 | 40 | 40 | 20 | 7 | | | | |
| ● | SCK5-A50-SVZCR16-58 | 58 | 32 | 50 | 45 | 22 | 7 | | | | |

●:庫存 In Stock ○:非標準庫存(請確認交貨期) Non-standard Stock

Zy 模組化內徑車刀頭 Modular Internal Head With Coolant

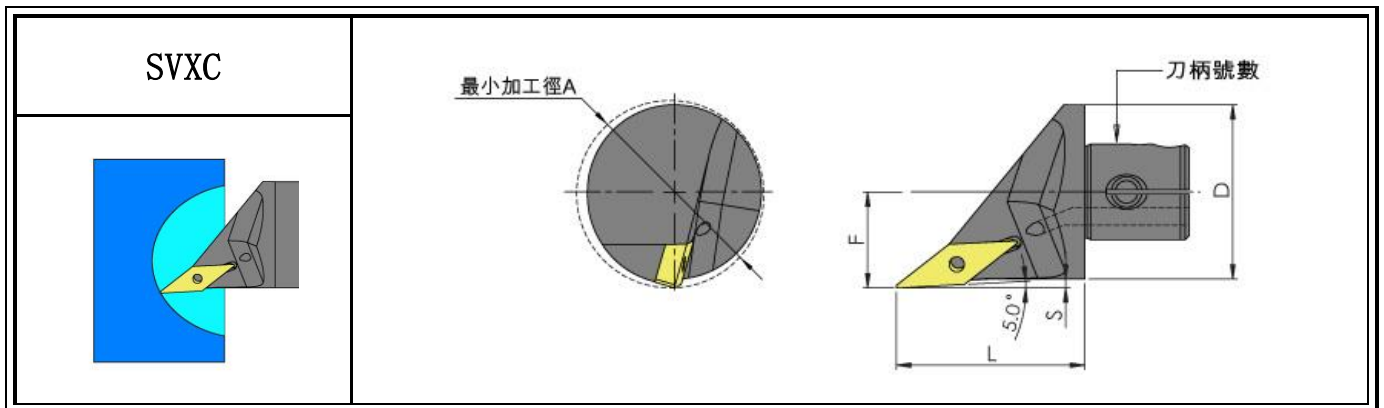

| Stock | 型號 Model No. | 最小加工徑 A | F | D | L | S | 螺絲 Screw | 扳手 Wrench | 刀片 Insert |
|-------|---------------------|---------|----|----|----|-----|---------------|-----------|-----------|
| ● | SCK1-A20-SVXCR11-22 | 22 | 11 | 20 | 28 | 1 | M2.5x6.0x3.6 | T8 | VC1103 |
| ○ | SCK2-A25-SVXCR11-28 | 28 | 14 | 25 | 29 | 1.5 | | | |
| ○ | SCK3-A32-SVXCR11-34 | 34 | 17 | 32 | 29 | 1 | | | |
| ○ | SCK4-A40-SVXCR11-42 | 42 | 21 | 40 | 29 | 1 | | | |
| ○ | SCK5-A50-SVXCR11-52 | 52 | 26 | 50 | 29 | 1 | | | |
| ● | SCK2-A25-SVXCR16-28 | 28 | 14 | 25 | 35 | 1.5 | M3.5x12.0x5.4 | T15 | VC1604 |
| ○ | SCK3-A32-SVXCR16-35 | 35 | 18 | 32 | 35 | 2 | | | |
| ● | SCK4-A40-SVXCR16-43 | 43 | 22 | 40 | 35 | 2 | | | |
| ○ | SCK5-A50-SVXCR16-52 | 52 | 26 | 50 | 35 | 1 | | | |

●:庫存 In Stock ○:非標準庫存(請確認交貨期) Non-standard Stock

Zy 模組化內徑車刀頭 Modular Internal Head With Coolant

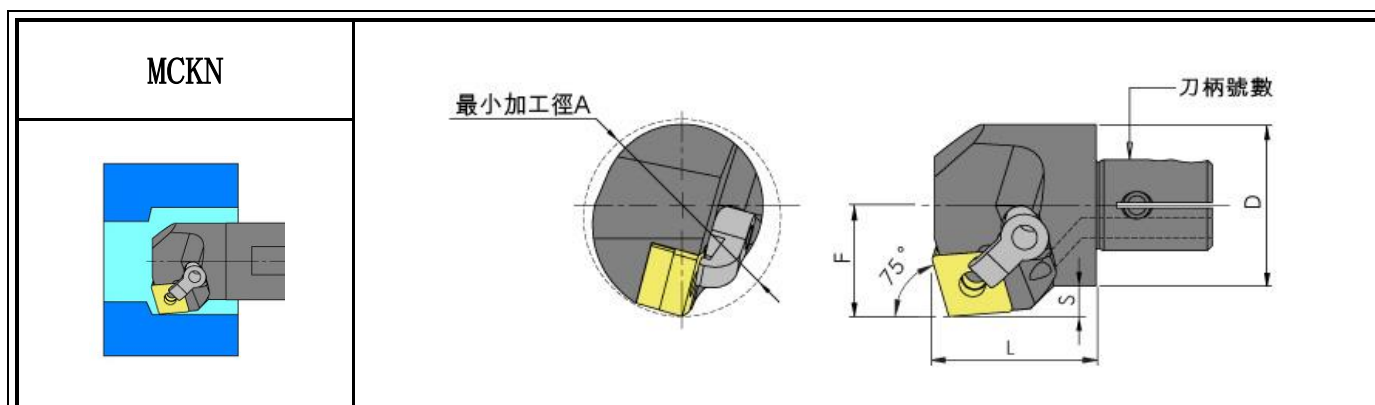

| Stock | 型號 Model No. | 最小加工徑 A | F | D | L | S | 墊片 Shim | 偏心螺絲 Shim Screw | 壓板 Clamp | 雙頭螺絲 Clamp Screw | 板手 Wrench |
|-------|---------------------|---------|----|----|----|---|---------|-----------------|----------|------------------|--------------|
| ● | SCK3-A32-MCKNR12-39 | 39 | 22 | 32 | 35 | 6 | CMS432 | LCS-617 | CP50-22 | MS625 | L2.5 L3.0 |
| ● | SCK4-A40-MCKNR12-46 | 46 | 25 | 40 | 35 | 5 | | | | | |
| | SCK5-A50-MCKNR12-60 | 60 | 30 | 50 | 36 | 5 | | | | | |

刀片 Insert : CNMG1204

●:庫存 In Stock ○:非標準庫存(請確認交貨期) Non-standard Stock

Zy 模組化內徑車刀頭 Modular Internal Head With Coolant

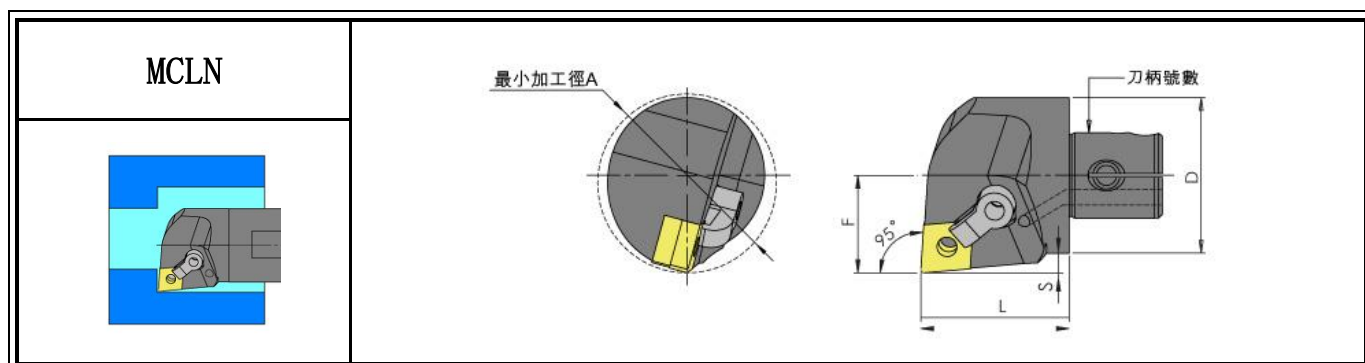

| Stock | 型號 Model No. | 最小加工徑 A | F | D | L | S | 墊片 Shim | 偏心螺絲 Shim Screw | 壓板 Clamp | 雙頭螺絲 Clamp Screw | 扳手 Wrench |
|-------|---------------------|---------|----|----|----|-----|---------|-----------------|----------|------------------|--------------|
| ● | SCK1-A20-MCLNR12-25 | 25 | 13 | 20 | 33 | 3 | - | LCS-511 | CP50-12 | MS520 | L2.5 |
| ● | SCK2-A25-MCLNR12-32 | 32 | 17 | 25 | 34 | 4.5 | - | LCS-511 | CP50-22 | MS620 | L2.5 L3.0 |
| ● | SCK3-A32-MCLNR12-40 | 40 | 20 | 32 | 35 | 4 | CMS432 | LCS-617 | CP50-22 | MS620 | L3.0 |
| ● | SCK4-A40-MCLNR12-46 | 46 | 25 | 40 | 35 | 5 | | LCS-617 | CP50-22 | MS625 | |
| ● | SCK5-A50-MCLNR12-60 | 60 | 30 | 50 | 36 | 5 | | LCS-617 | CP50-22 | MS625 | |

刀片 Insert : CNMG1204

●:庫存 In Stock ○:非標準庫存(請確認交貨期) Non-standard Stock

Zy 模組化內徑車刀頭 Modular Internal Head With Coolant

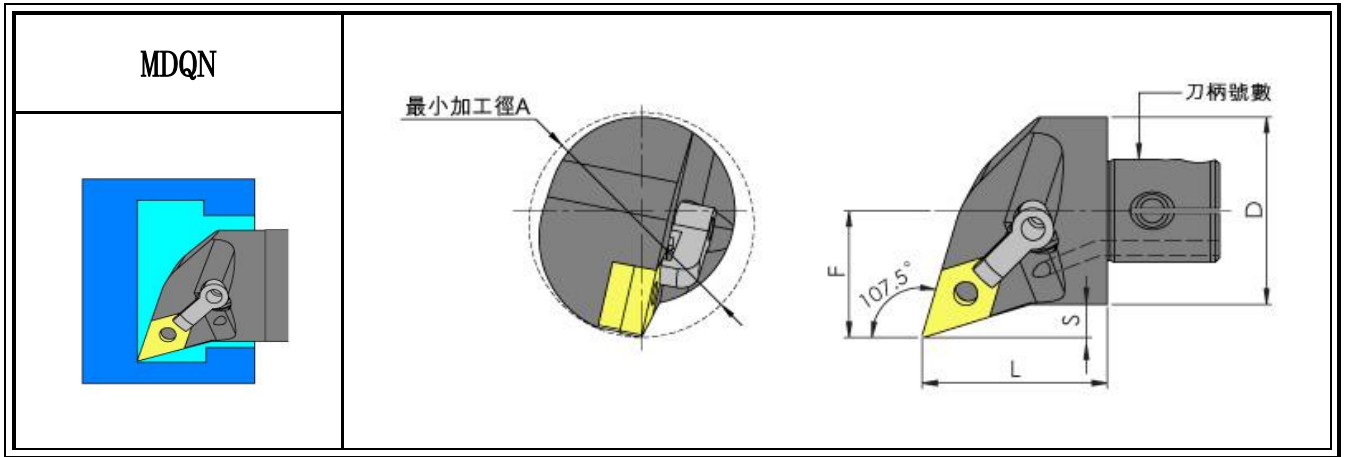

| Stock | 型號 Model No. | 最小加工徑 A | F | D | L | S | 墊片 Shim | 偏心螺絲 Shim Screw | 壓板 Clamp | 雙頭螺絲 Clamp Screw | 扳手 Wrench |
|-------|---------------------|---------|----|----|----|-----|---------|-----------------|----------|------------------|-----------|
| ○ | SCK2-A25-MDQNR15-32 | 32 | 16 | 25 | 36 | 3.5 | - | LCS-617 | CP50-24 | MS625 | L3.0 |
| ● | SCK3-A32-MDQNR15-39 | 39 | 22 | 32 | 39 | 6 | DMS442 | | | | |
| ● | SCK4-A40-MDQNR15-48 | 48 | 27 | 40 | 42 | 7 | | | | | |
| ● | SCK5-A50-MDQNR15-58 | 58 | 32 | 50 | 45 | 7 | | | | | |

刀片 Insert : DN1504

●:庫存 In Stock ○:非標準庫存(請確認交貨期) Non-standard Stock

Zy 模組化內徑車刀頭 Modular Internal Head With Coolant

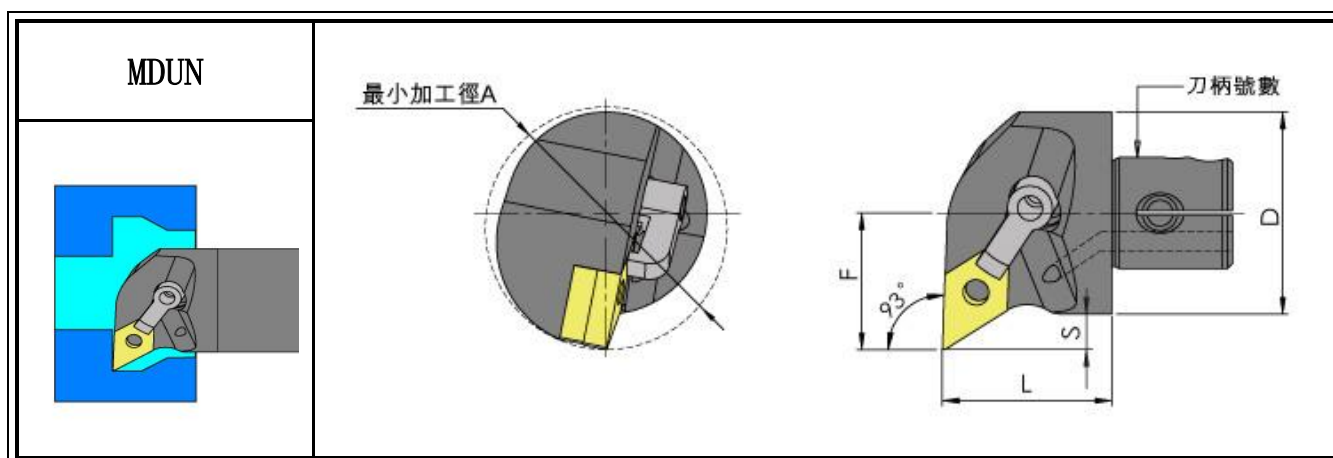

| Stock | 型號 Model No. | 最小加工徑 A | F | D | L | S | 墊片 Shim | 偏心螺絲 Shim Screw | 壓板 Clamp | 雙頭螺絲 Clamp Screw | 板手 Wrench |
|-------|---------------------|---------|----|----|----|-----|---------|-----------------|----------|------------------|-----------|
| ○ | SCK2-A25-MDUNR15-32 | 32 | 16 | 25 | 36 | 3.5 | - | LCS-617 | CP50-24 | MS625 | L3.0 |
| ● | SCK3-A32-MDUNR15-39 | 39 | 22 | 32 | 39 | 6 | DMS442 | | | | |
| ● | SCK4-A40-MDUNR15-48 | 48 | 27 | 40 | 42 | 7 | | | | | |
| ● | SCK5-A50-MDUNR15-60 | 60 | 32 | 50 | 45 | 7 | | | | | |

刀片 Insert : DN1504

●: 庫存 ○: 非標準庫存 (請確認交貨期)

Zy 模組化內徑車刀頭

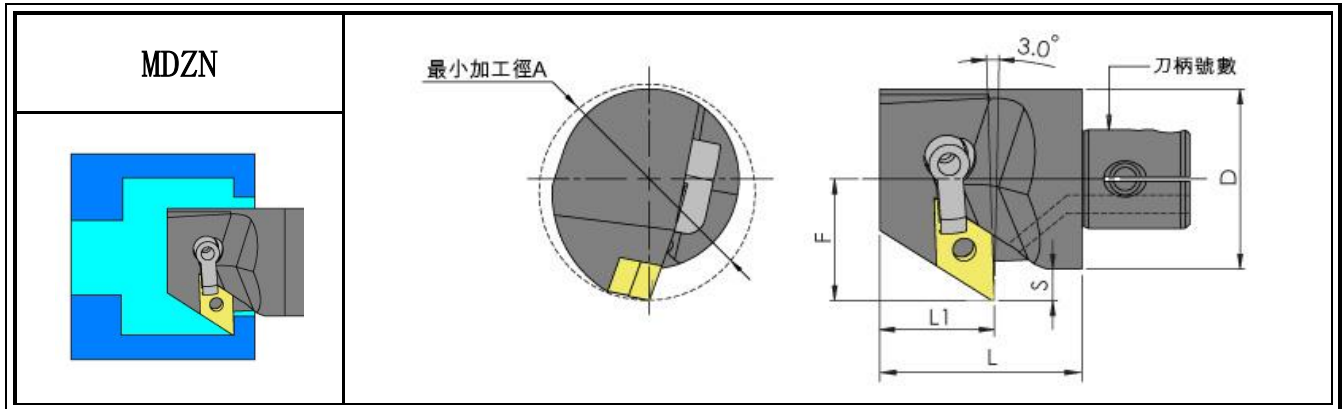

| Stock | 型號 Model No. | 最小加工徑 A | F | D | L | S | 墊片 Shim | 偏心螺絲 Shim Screw | 壓板 Clamp | 雙頭螺絲 Clamp Screw | 板手 Wrench |
|-------|---------------------|---------|------|----|----|-----|---------|-----------------|----------|------------------|-----------|
| ● | SCK3-A32-MDZNR15-39 | 39 | 22 | 32 | 39 | 6 | DMS442 | LCS-617 | CP50-24 | MS625 | L3.0 |
| ● | SCK4-A40-MDZNR15-48 | 48 | 27 | 40 | 42 | 7 | | | | | |
| | SCK5-A50-MDZNR15-59 | 59 | 32.5 | 50 | 45 | 7.5 | | | | | |

刀片 Insert : DN1504

●:庫存 In Stock ○:非標準庫存(請確認交貨期) Non-standard Stock

Zy 模組化內徑車刀頭 Modular Internal Head With Coolant

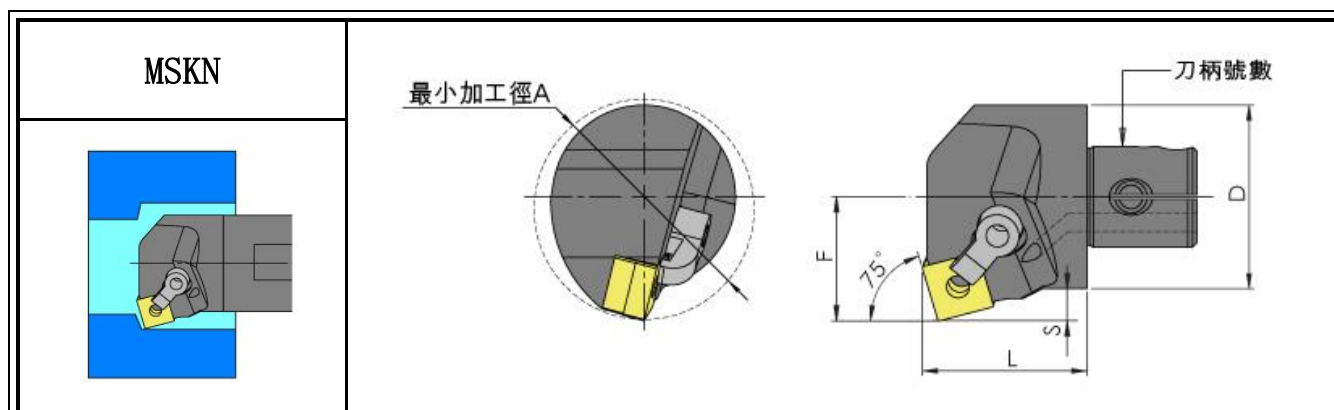

| Stock | 型號 Model No. | 最小加工徑 A | F | D | L | S | 墊片 Shim | 偏心螺絲 Shim Screw | 壓板 Clamp | 雙頭螺絲 Clamp Screw | 板手 Wrench |
|-------|---------------------|---------|------|----|----|-----|---------|-----------------|----------|------------------|-----------|
| ● | SCK3-A32-MSKNR12-39 | 39 | 22 | 32 | 39 | 6 | GMS432 | LCS-617 | CP50-22 | MS625 | L3.0 |
| ● | SCK4-A40-MSKNR12-48 | 48 | 27 | 40 | 42 | 7 | | | | | |
| ● | SCK5-A50-MSKNR12-59 | 59 | 32.5 | 50 | 45 | 7.5 | | | | | |

刀片 Insert : SN1204

●:庫存 In Stock ○:非標準庫存(請確認交貨期) Non-standard Stock

Zy 模組化內徑車刀頭 Modular Internal Head With Coolant

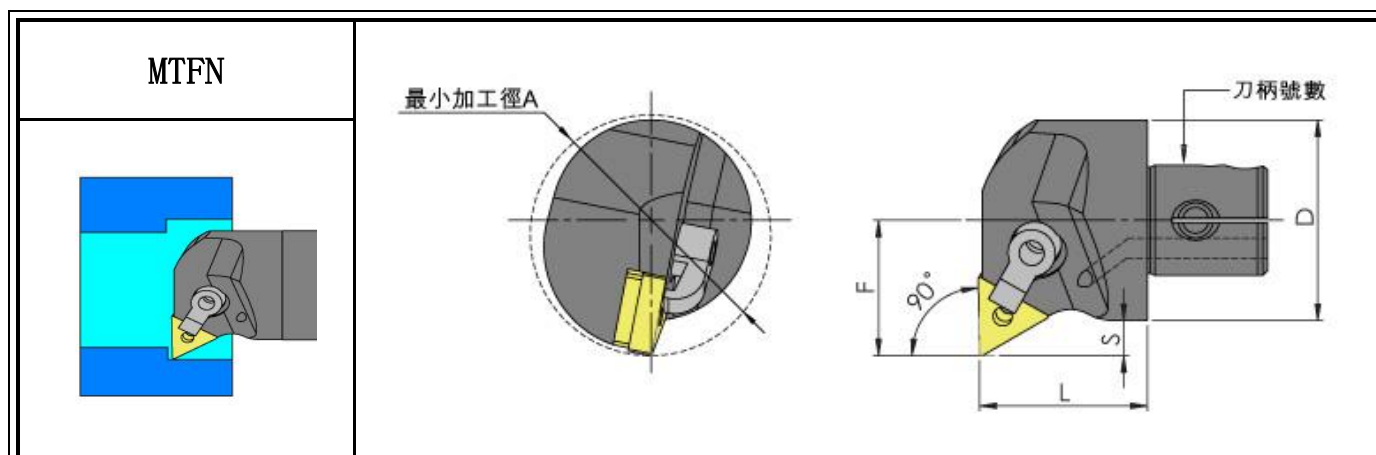

| Stock | 型號 Model No. | 最小加工徑 A | F | D | L | S | 墊片 Shim | 偏心螺絲 Shim Screw | 壓板 Clamp | 雙頭螺絲 Clamp Screw | 扳手 Wrench |
|-------|---------------------|---------|----|----|----|---|---------|-----------------|----------|------------------|--------------|
| ● | SCK3-A32-MTFNR16-39 | 39 | 22 | 32 | 35 | 6 | TMS322 | LCS-513 | CP50-22 | MS625 | L2.0 L3.0 |
| ● | SCK4-A40-MTFNR16-48 | 48 | 27 | 40 | 35 | 7 | | | | | |
| ● | SCK5-A50-MTFNR16-57 | 57 | 31 | 50 | 36 | 6 | | | | | |

刀片 Insert : TN1604

●:庫存 In Stock ○:非標準庫存(請確認交貨期) Non-standard Stock

Zy 模組化內徑車刀頭 Modular Internal Head With Coolant

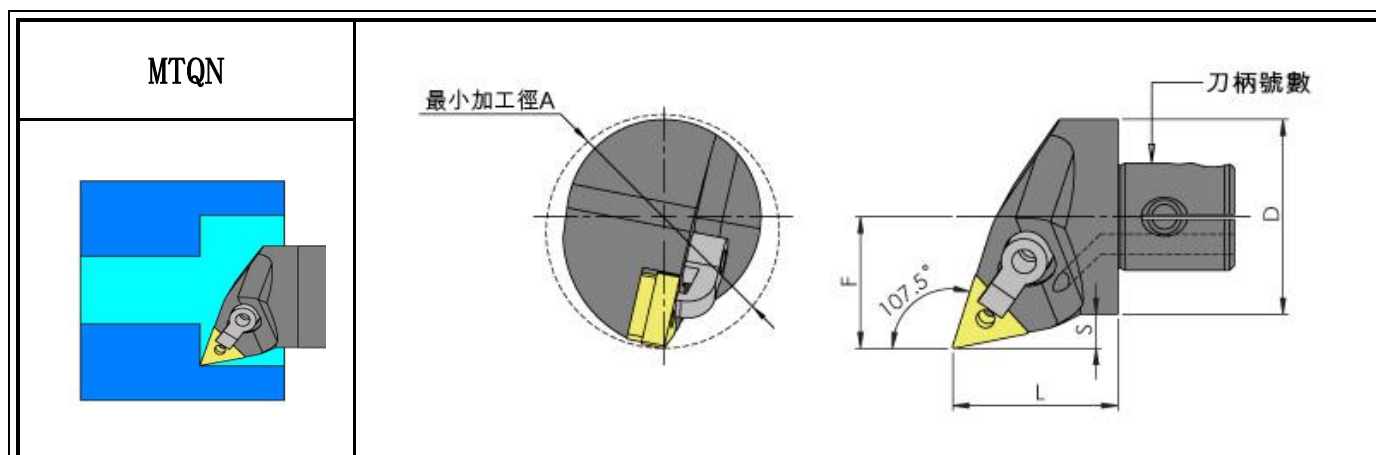

| Stock | 型號 Model No. | 最小加工徑 A | F | D | L | S | 墊片 Shim | 偏心螺絲 Shim Screw | 壓板 Clamp | 雙頭螺絲 Clamp Screw | 板手 Wrench |
|-------|---------------------|---------|------|----|----|-----|---------|-----------------|----------|------------------|--------------|
| ○ | SCK1-A20-MTQNR16-25 | 25 | 13 | 20 | 29 | 3 | - | LCS-510 | CP50-12 | MS520 | L2.0 L2.5 |
| ● | SCK2-A25-MTQNR16-29 | 29 | 12.5 | 25 | 29 | 2.5 | - | LCS-510 | CP50-22 | MS625 | L2.0 L3.0 |
| ○ | SCK3-A32-MTQNR16-40 | 40 | 22.5 | 32 | 35 | 6.5 | TMS322 | LCS-513 | CP50-22 | MS625 | L2.0 L3.0 |
| ● | SCK4-A40-MTQNR16-48 | 48 | 27 | 40 | 35 | 7 | | | | | |
| ● | SCK5-A50-MTQNR16-57 | 57 | 31 | 50 | 36 | 6 | | | | | |

刀片 Insert : TN1604

●:庫存 In Stock ○:非標準庫存(請確認交貨期) Non-standard Stock

Zy 模組化內徑車刀頭 Modular Internal Head With Coolant

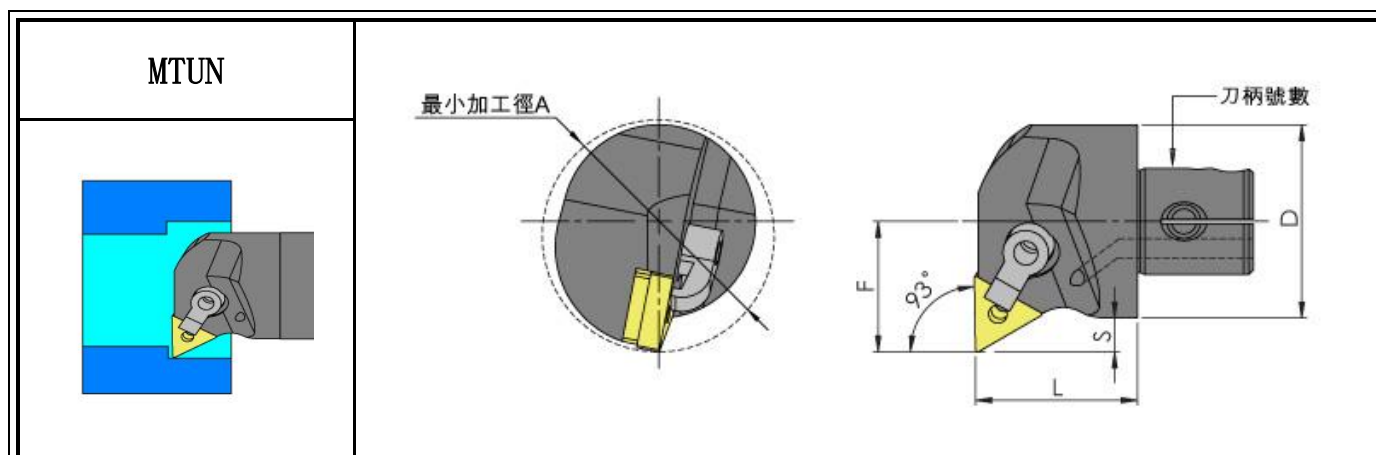

| Stock | 型號 Model No. | 最小加工徑 A | F | D | L | S | 墊片 Shim | 偏心螺絲 Shim Screw | 壓板 Clamp | 雙頭螺絲 Clamp Screw | 板手 Wrench |
|-------|----------------------|---------|----|----|----|-----|---------|-----------------|----------|------------------|--------------|
| ● | SCK1-A20-MTUNR16-25A | 25 | 13 | 20 | 29 | 3 | - | LCS-510 | CP50-12 | MS520 | L2.0 L2.5 |
| ● | SCK2-A25-MTUNR16-32A | 32 | 17 | 25 | 30 | 4.5 | - | LCS-510 | CP50-22 | MS620 | L2.0 L3.0 |
| ● | SCK3-A32-MTUNR16-40A | 40 | 20 | 32 | 34 | 4 | TMS322 | LCS-513 | | MS625 | |
| ● | SCK4-A40-MTUNR16-47A | 47 | 26 | 40 | 35 | 6 | | | | | |
| ● | SCK5-A50-MTUNR16-57A | 57 | 31 | 50 | 45 | 7 | | | | | |

刀片 Insert : TN1604

●:庫存 In Stock ○:非標準庫存(請確認交貨期) Non-standard Stock

Zy 模組化內徑車刀頭 Modular Internal Head With Coolant

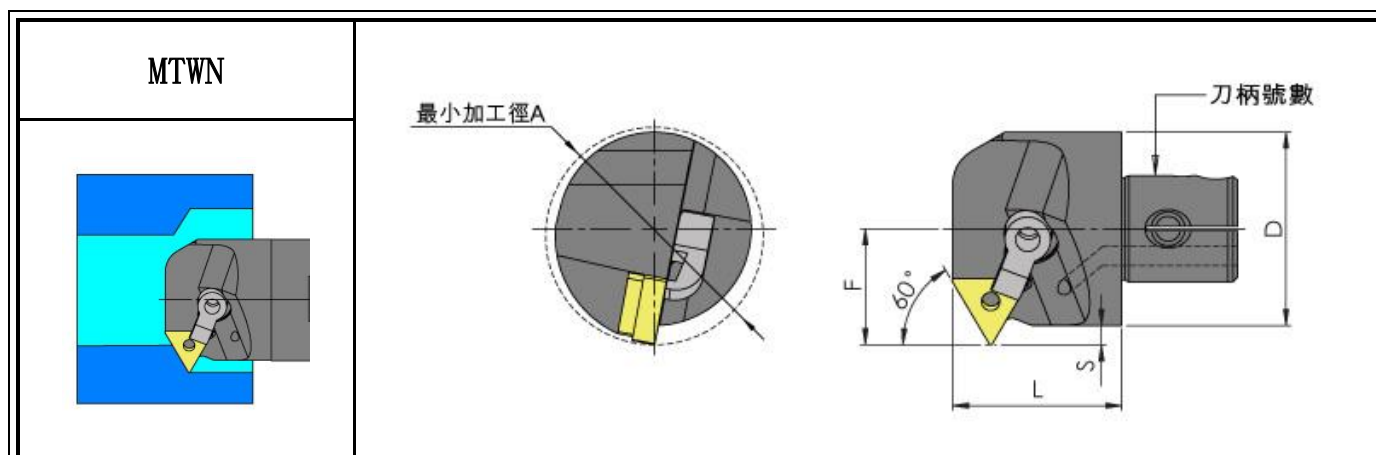

| Stock | 型號 Model No. | 最小加工徑 A | F | D | L | S | 墊片 Shim | 偏心螺絲 Shim Screw | 壓板 Clamp | 雙頭螺絲 Clamp Screw | 板手 Wrench |
|-------|--------------------|---------|----|----|----|---|---------|-----------------|----------|------------------|--------------|
| ● | SCK3-A32-MTWR16-37 | 40 | 20 | 32 | 35 | 4 | TMS322 | LCS-513 | CP50-22 | MS625 | L2.0 L3.0 |
| ● | SCK4-A40-MTWR16-45 | 48 | 24 | 40 | 35 | 4 | | | | | |
| ● | SCK5-A50-MTWR16-55 | 57 | 29 | 50 | 36 | 4 | | | | | |

刀片 Insert : TN1604

●:庫存 In Stock ○:非標準庫存(請確認交貨期) Non-standard Stock

Zy 模組化內徑車刀頭

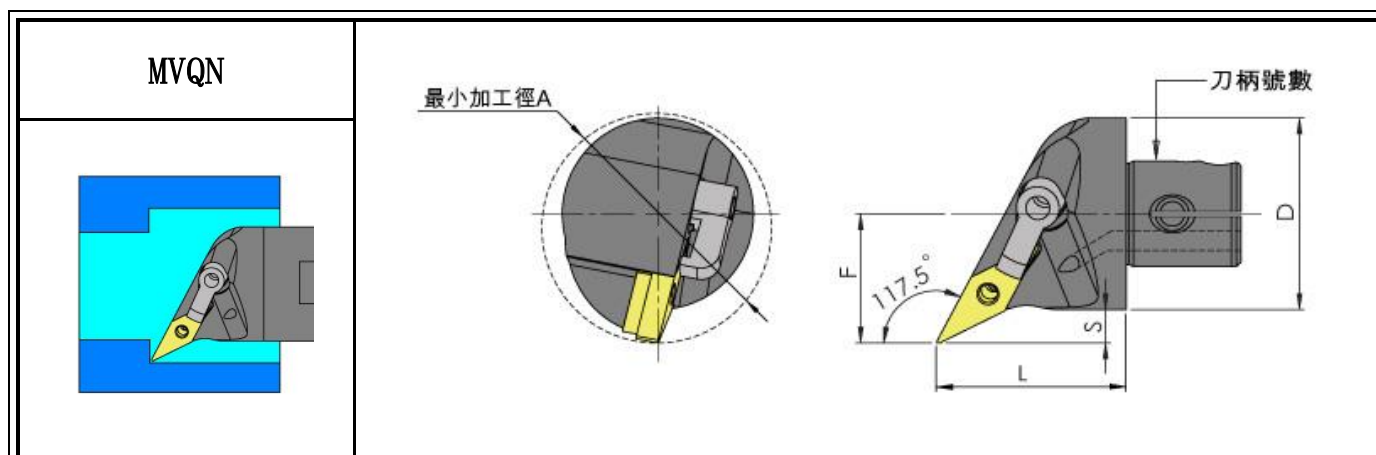

| Stock | 型號 Model No. | 最小加工徑 A | F | D | L | S | 墊片 Shim | 偏心螺絲 Shim Screw | 壓板 Clamp | 雙頭螺絲 Clamp Screw | 板手 Wrench |
|-------|---------------------|---------|----|----|----|-----|---------|-----------------|----------|------------------|--------------|
| ○ | SCK2-A25-MVQNR16-32 | 32 | 20 | 25 | 35 | 7.5 | - | LCS-513 | CP50-24 | MS625 | L2.0 L3.0 |
| ● | SCK3-A32-MVQNR16-40 | 40 | 23 | 32 | 35 | 7 | | | | | |
| ● | SCK4-A40-MVQNR16-48 | 48 | 27 | 40 | 35 | 7 | | | | | |
| ● | SCK5-A50-MVQNR16-59 | 59 | 33 | 50 | 35 | 8 | | | | | |

刀片 Insert : VN1604

●:庫存 In Stock ○:非標準庫存(請確認交貨期) Non-standard Stock

Zy 模組化內徑車刀頭 Modular Internal Head With Coolant

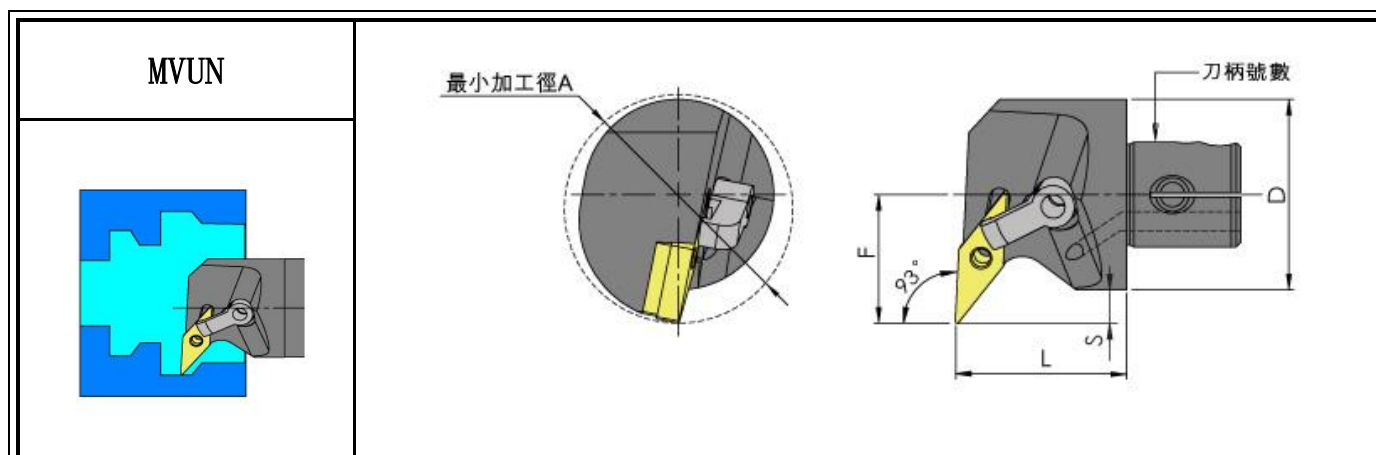

| Stock | 型號 Model No. | 最小加工徑 A | F | D | L | S | 墊片 Shim | 偏心螺絲 Shim Screw | 壓板 Clamp | 雙頭螺絲 Clamp Screw | 扳手 Wrench |
|-------|---------------------|---------|----|----|----|-----|---------|-----------------|----------|------------------|--------------|
| ● | SCK2-A25-MVUNR16-32 | 32 | 18 | 25 | 35 | 5.5 | - | LCS-513 | CP50-24 | MS625 | P2.0 P3.0 |
| ● | SCK3-A32-MVUNR16-39 | 39 | 23 | 32 | 35 | 6 | | | | | |
| ● | SCK4-A40-MVUNR16-48 | 48 | 27 | 40 | 35 | 7 | | | | | |
| ● | SCK5-A50-MVUNR16-59 | 59 | 33 | 50 | 35 | 8 | | | | | |

刀片 Insert : VN1604

●:庫存 In Stock ○:非標準庫存(請確認交貨期) Non-standard Stock

Zy 模組化內徑車刀頭 Modular Internal Head With Coolant

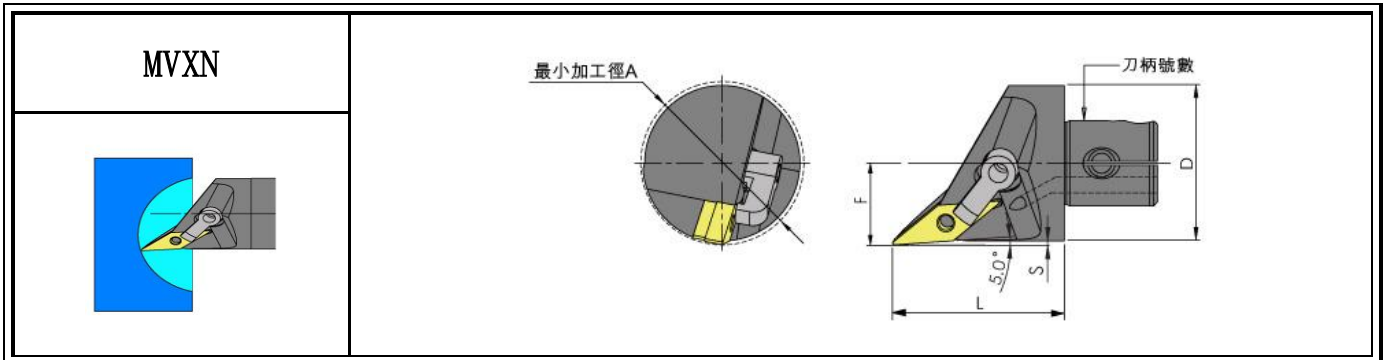

| Stock | 型號 Model No. | 最小加工徑 A | F | D | L | S | 墊片 Shim | 偏心螺絲 Shim Screw | 壓板 Clamp | 雙頭螺絲 Clamp Screw | 板手 Wrench |
|-------|---------------------|---------|----|----|----|---|---------|-----------------|----------|------------------|-----------|
| ● | SCK3-A32-MVXNR16-40 | 40 | 23 | 32 | 35 | 7 | | | | | |
| ● | SCK4-A40-MVXNR16-42 | 42 | 21 | 40 | 35 | 1 | GMV322 | LCS-513 | CP50-24 | MS625 | L2.0 |
| ● | SCK5-A50-MVXNR16-57 | 57 | 31 | 50 | 35 | 6 | | | | | L3.0 |

刀片 Insert : VN1604

●:庫存 In Stock ○:非標準庫存(請確認交貨期) Non-standard Stock

Zy 模組化內徑車刀頭 Modular Internal Head With Coolant

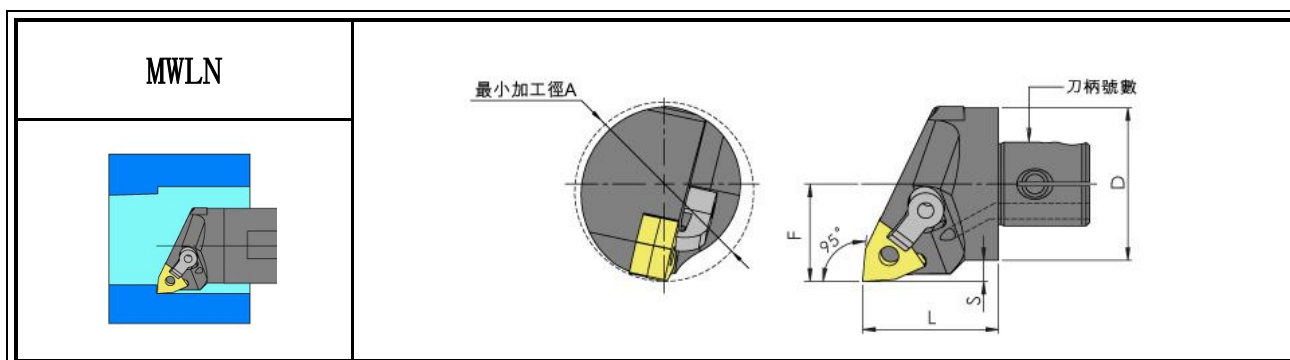

| Stock | 型號 Model No. | 最小加工徑 A | F | D | L | S | 墊片 Shim | 偏心螺絲 Shim Screw | 壓板 Clamp | 雙頭螺絲 Shim Screw | 板手 Wrench |
|-------|----------------------|---------|------|----|----|-----|---------|-----------------|----------|-----------------|--------------|
| ● | SCK1-A20-MWLN R08-25 | 25 | 13 | 20 | 36 | 3 | - | LCS-511 | CP50-12 | MS520 | L2.5 |
| ● | SCK2-A25-MWLN R08-32 | 32 | 17 | 25 | 36 | 4.5 | - | | | | |
| ● | SCK3-A32-MWLN R08-40 | 40 | 20 | 32 | 39 | 4 | WMS432 | LCS-617 | CP50-22 | MS625 | L2.5 L3.0 |
| ● | SCK4-A40-MWLN R08-47 | 47 | 25.5 | 40 | 42 | 5.5 | | | | | |
| ● | SCK5-A50-MWLN R08-57 | 57 | 30.5 | 50 | 45 | 5.5 | | | | | |

刀片 Insert : WN0804

●:庫存 In Stock ○:非標準庫存(請確認交貨期) Non-standard Stock