

切槽刀系列

- 內徑切槽刀
- 內徑端面切槽
- 外徑切槽
- 外徑端面切槽

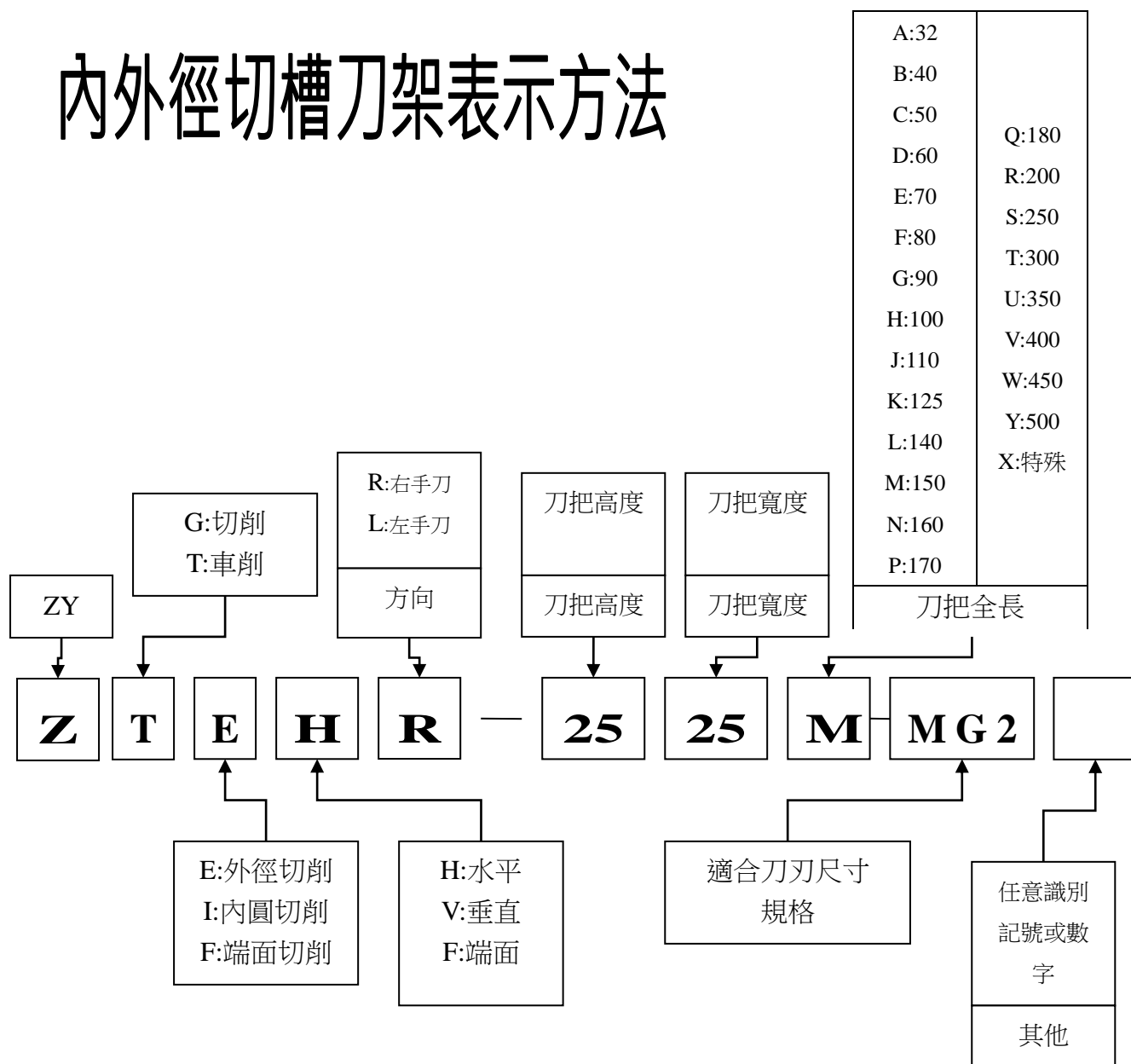





內外徑切槽刀架表示方法

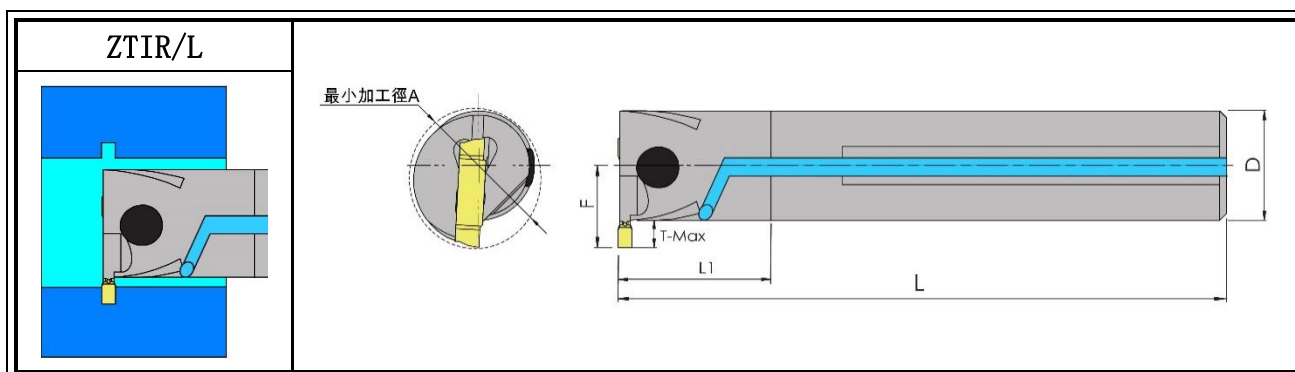

Zy 內徑切槽刀 Internal Grooving With Coolant



Stock		型號 Model No.	最小加工徑 A	F	D	L	L1	T-Max	 螺絲 Screw	 板手 Wrench
R	L									
●	○	ZTIR/L-2016K-MG2-4	20	12	16	125	25	4	M4-12-5.6-60	T15

Stock		型號 Model No.	最小加工徑	F	D	L	L1	T-Max	 螺絲 Screw	 板手 Wrench
R	L									
○	○	ZTIR/L-2520M-MG2-4	25	14.5	20	150	25	4	HTM5x12L	P4.0
○	○	ZTIR/L-2925R-MG2-4	29	16.5	25	200	30	4		
○	○	ZTIR/L-2620M-MG3-6	26	16	20	150	25	6	HTM5x12L	P4.0
○	○	ZTIR/L-3125R-MG3-6	31	18.5	25	200	30	6		
●	○	ZTIR/L-3832S-MG3-6	38	22	32	250	40	6	HTM5x12L	P4.0
○	○	ZTIR/L-2620M-MG4-6	26	16	20	150	25	6		
○	○	ZTIR/L-3125R-MG4-6	31	18.5	25	200	30	6	HTM5x12L	P4.0
○	○	ZTIR/L-3832S-MG4-6	38	22	32	250	40	6		
○	○	ZTIR/L-3125R-MG5-8	31	19.5	25	200	30	8	HTM6x16L	P5.0
○	○	ZTIR/L-3832S-MG5-6	38	22	32	250	40	6		

●:庫存 In Stock ○:非標準庫存(請確認交貨期) Non-standard Stock

刀片 Insert : KORLOY

MG2= MGMT200

MG3= MGMT300

MG4= MGMT400

MG5= MGMT500



Zy 內徑切槽刀 Internal Grooving With Coolant

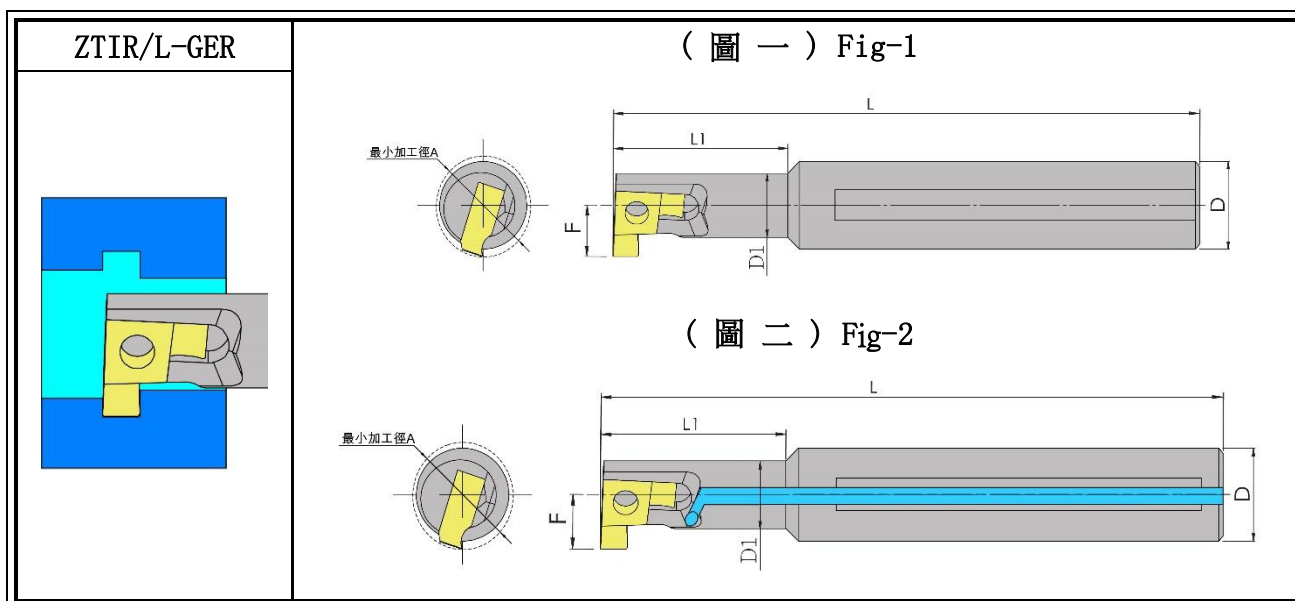

Stock	型號 Model No.	最小加工徑 A	F	D	D1	L	L1	螺絲 Screw	扳手 Wrench	刀片 Insert
鎢鋼柄 (圖一) Carbide Shank (Fig-1)										
○	ZTIR-C0808J-GER-A	8	4.8	8	5.9	110	20	M2. 2x5. 6x3. 3	T7	GER...A
●	ZTIR-C1008K-GER-B	10	5.85	8	7.3	125	15			GER...B
○	ZTIR-C1010K-GER-B	10	6.2	10	7	125	25			GER...B
○	ZTIR-C1210K-GER-B	12	7	10	9	125	30			GER...B
鎢鋼柄 + 水孔 (圖二) Carbide Shank With Coolant (Fig-2)										
○	ZTIR-E0808J-GER-A	8	4.8	8	5.9	110	20	M2. 2x5. 6x3. 3	T7	GER...A
●	ZTIR-E1008K-GER-B	10	5.85	8	7.3	125	15			GER...B
○	ZTIR-E1010K-GER-B	10	6.2	10	7	125	25			GER...B
○	ZTIR-E1210K-GER-B	12	7	10	9	125	30			GER...B

●:庫存 In Stock ○:非標準庫存(請確認交貨期) Non-standard Stock

Zy 內徑端面切槽刀 Internal Face Grooving With Coolant

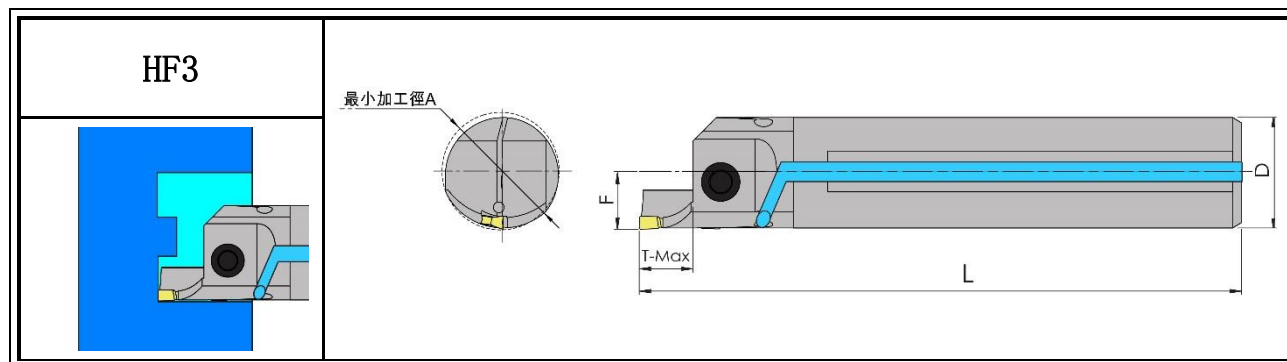

Stock	型號 Model No.	A 最小 A Max	A 最大 A Min	F	D	L	T-Max	螺絲 Screw	板手 Wrench
●	ZTIFR-2530A25M-HF3-12	25	30	13.5	25	150	12	HTM5x16L	P4.0
●	ZTIFR-3038A25M-HF3-12	30	38		25	150			
●	ZTIFR-3848A25M-HF3-12	38	48		25	150			
●	ZTIFR-4860A25M-HF3-12	48	60		25	150			
●	ZTIFR-6075A25M-HF3-22	60	75		25	150	22		
●	ZTIFR-75100A25M-HF3-25	75	100		25	150	25		

●:庫存 In Stock ○:非標準庫存(請確認交貨期) Non-standard Stock

刀片 Insert : ISCAR

Zy 內徑端面切槽刀 Internal Face Grooving With Coolant

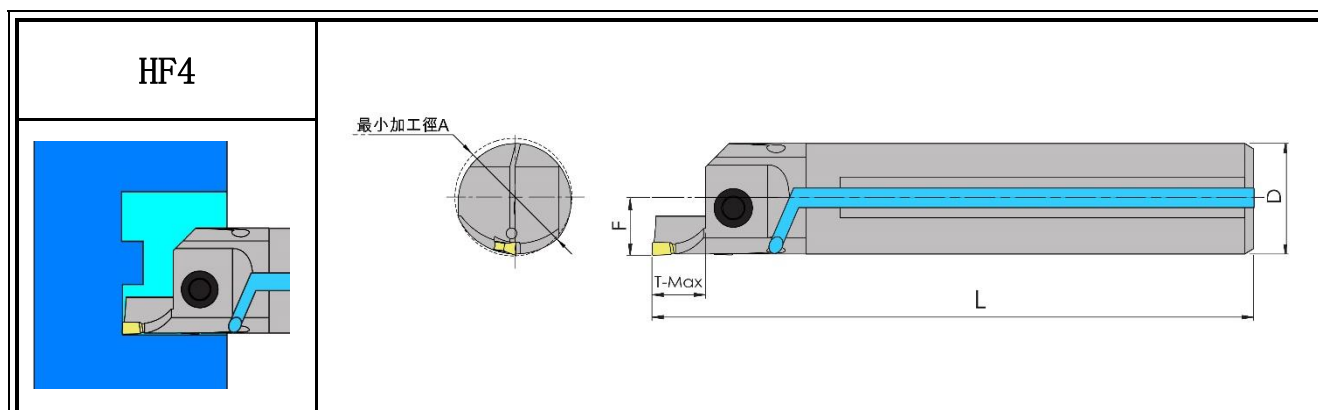

Stock	型號 Model No.	A 最小 A Max	A 最大 A Min	F	D	L	T-Max	螺絲 Screw	扳手 Wrench
●	ZTIFR-2529A25M-HF4-12	25	29	13.5	25	150	12	HTM5x16L	P4.0
●	ZTIFR-2934A25M-HF4-12	29	34		25	150			
●	ZTIFR-3440A25M-HF4-20	34	40		25	150			
●	ZTIFR-4048A25M-HF4-25	40	48		25	150	25		
●	ZTIFR-4860A25M-HF4-25	48	60		25	150			
●	ZTIFR-6075A25M-HF4-25	60	75		25	150			
●	ZTIFR-75100A32R-HF4-25	75	100	17	32	200	25	HTM5x16L	P4.0
●	ZTIFR-100140A32R-HF4-25	100	140		32	200			
●	ZTIFR-140240A32R-HF4-25	140	240		32	200			
●	ZTIFR-240800A32R-HF4-25	240	800		32	200			

●:庫存 In Stock ○:非標準庫存(請確認交貨期) Non-standard Stock

刀片 Insert : ISCAR

Zy 內徑端面切槽刀 Internal Face Grooving With Coolant

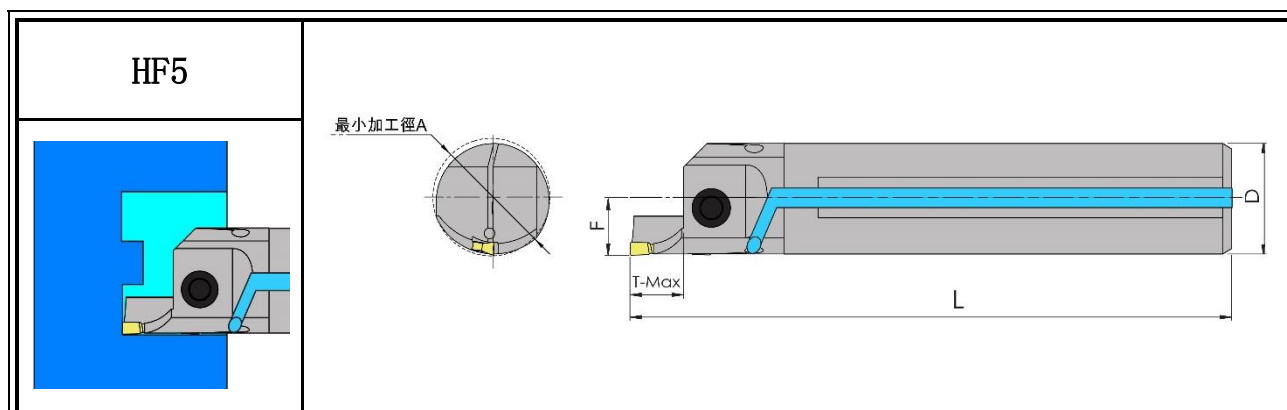



Stock	型號 Model No.	A 最小 A Max	A 最大 A Min	F	D	L	T-Max	螺絲 Screw	扳手 Wrench
●	ZTIFR-2529A25M-HF5-20	25	29	13.5	25	150	20	HTM5x16L	P4.0
●	ZTIFR-2530A25M-HF5-12	25	30		25	150	12		
●	ZTIFR-2831A25M-HF5-17	28	31		25	150	17		
●	ZTIFR-3135A25M-HF5-17	31	35		25	150	17		
●	ZTIFR-3540A25M-HF5-20	32	40		25	150	20		
●	ZTIFR-4045A25M-HF5-20	40	45		25	150	20		
●	ZTIFR-4555A25M-HF5-25	45	55		25	150	25		
○	ZTIFR-5570A32R-HF5-25	55	70	17	32	200	25	HTM5x16L	P4.0
○	ZTIFR-7095A32R-HF5-25	70	95		32	200			
○	ZTIFR-95130A32R-HF5-25	95	130		32	200			
○	ZTIFR-130180A32R-HF5-25	130	180		32	200			
○	ZTIFR-180800A32R-HF5-25	180	800		32	200			
○	ZTIFR-200800A32R-HF5-25	200	800		32	200			

●:庫存 In Stock ○:非標準庫存(請確認交貨期) Non-standard Stock

刀片 Insert : ISCAR

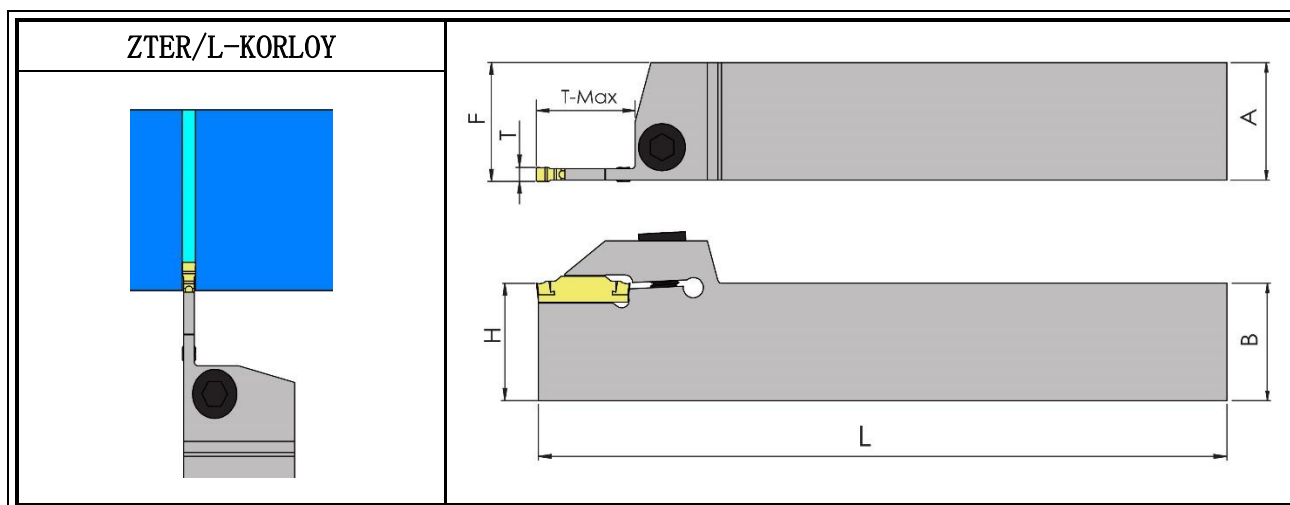
Zy 外徑切槽刀 External Grooving



Stock		型號 Model No.	A	B=H	F	L	T	T-Max	 螺絲 Screw	 板手 Wrench
R	L									
●	●	ZTER/L-2020K-MG2-14	20	20	20	125	2	14	HTM6x20L	P5.0
●	●	ZTER/L-2020K-MG2-18	20	20	20	125		18	HTM6x20L	
●	●	ZTER/L-2525M-MG2-14	25	25	25	150	2	14	HTM6x25L	
●	●	ZTER/L-2525M-MG2-18	25	25	25	150		18	HTM6x25L	
●	●	ZTER/L-2020K-MG3-20	20	20	20	125	3	20	HTM6x20L	P5.0
●	○	ZTER/L-2525M-MG3-10	25	25	25	150		10	HTM6x25L	
●	●	ZTER/L-2525M-MG3-20	25	25	25	150		20	HTM6x25L	
●	●	ZTER/L-2020K-MG4-20	20	20	20	125	4	20	HTM6x20L	P5.0
●	●	ZTER/L-2525M-MG4-20	25	25	25	150		20	HTM6x25L	
○	○	ZTER/L-2020K-MG5-25	20	20	20	125	5	25	HTM6x20L	P5.0
●	●	ZTER/L-2525M-MG5-25	25	25	25	150		25	HTM6x25L	

●:庫存 In Stock ○:非標準庫存(請確認交貨期) Non-standard Stock

刀片 Insert : KORLOY

MG2= MGN200

MG3= MGN300



MG4= MGN400

MG5= MGN500

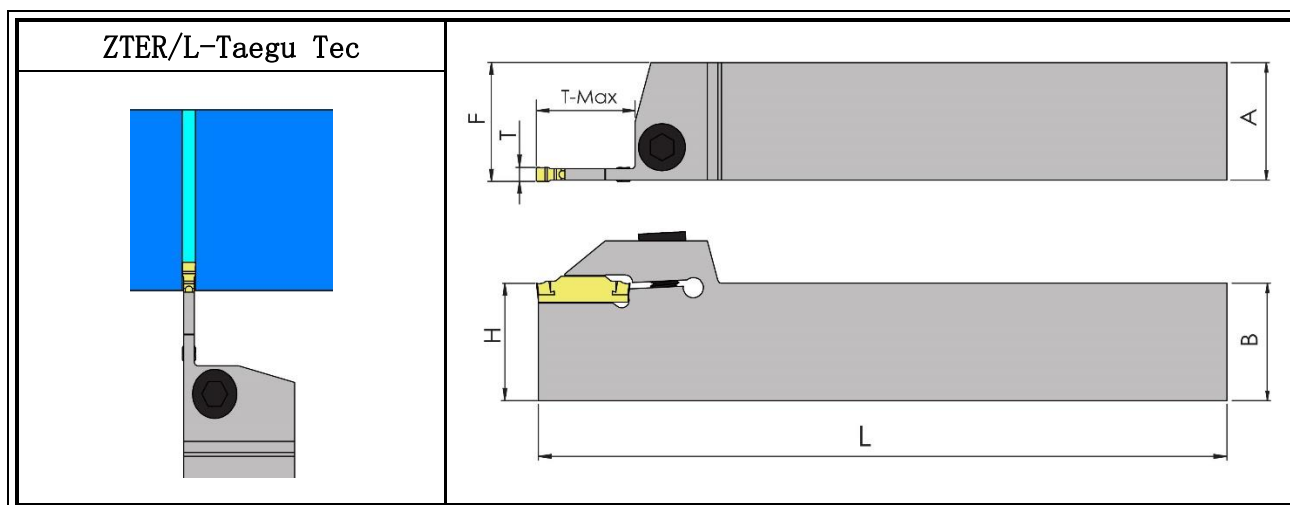

Zy 外徑切槽刀 External Grooving





Stock		型號 Model No.	A	B=H	F	L	T	T-Max	 螺絲 Screw	 板手 Wrench
R	L									
●	●	ZTER/L-2020K-TD2-17	20	20.1	20	125	2	17	HTM6x20L	P5.0
●	○	ZTER/L-2525M-TD2-17	25	25.1	25	150	2	17	HTM6x25L	
●	○	ZTER/L-2020K-TD3-20	20	20.3	20	125	3	20	HTM6x20L	
●	○	ZTER/L-2525M-TD3-20	25	25.3	25	150	3	20	HTM6x25L	
●	○	ZTER/L-2525M-TD4-25	25	25.5	25	150	4	25	HTM6x16L	
●	○	ZTER/L-2525M-TD5-32	25	25.5	25	150	5	32	HTM6x25L	

●:庫存 In Stock ○:非標準庫存(請確認交貨期) Non-standard Stock

刀片 Insert : Taegu Tec

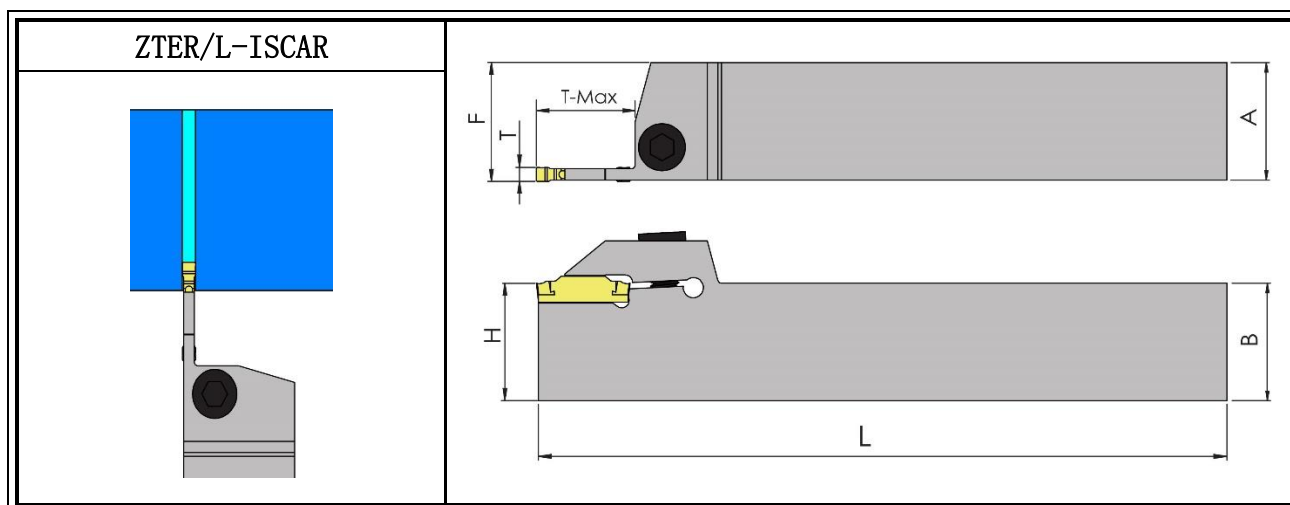
Zy 外徑切槽刀 External Grooving



Stock		型號 Model No.	A	B=H	F	L	T	T-Max	 螺絲 Screw	 板手 Wrench
R	L									
●	●	ZTER/L-2020K-DGN2-17	20	20	20	125	2	17	HTM6x20L	P5.0
●	●	ZTER/L-2525M-DGN2-17	25	25	25	150	2	17	HTM6x25L	
●	●	ZTER/L-2020K-DGN3-20	20	20	20	125	3	20	HTM6x20L	
●	●	ZTER/L-2525M-DGN3-20	25	25	25	150	3	20	HTM6x25L	



●:庫存 In Stock ○:非標準庫存(請確認交貨期) Non-standard Stock

刀片 Insert : ISCAR

Zy 外徑切槽刀-自動車床用

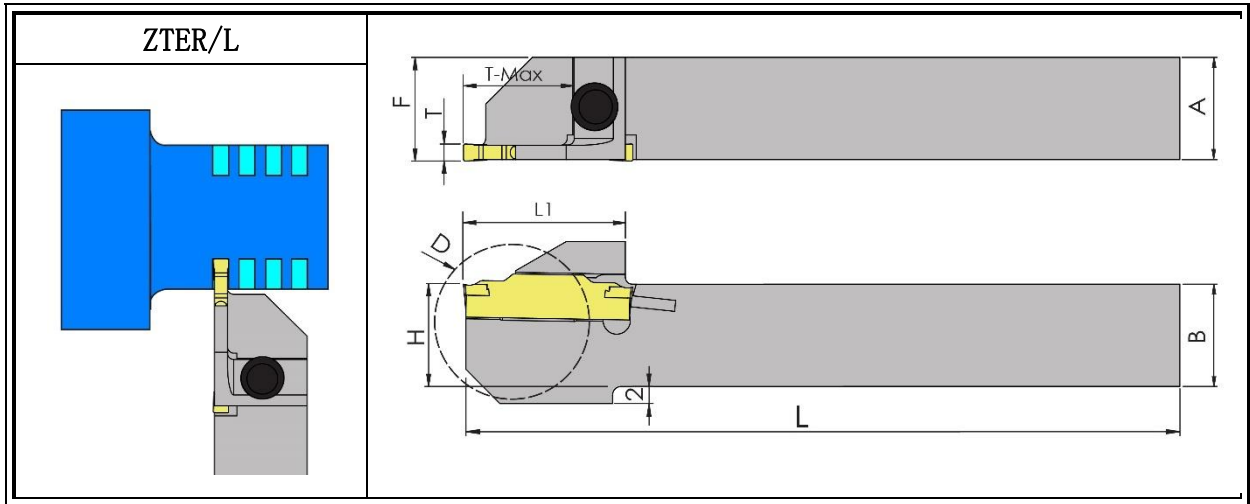

External Grooving
For Automatic Lathes



Stock		型號 Model No.	D	A	B=H	L	L1	T	T-Max	 螺絲 Screw	 板手 Wrench
R	L										
●	●	ZTER/L-1010K-MGX20A-10	20	10	10	125	18	2	10.5	M4x12.0x5.6	T15
●	●	ZTER/L-1212K-MGX20A-12.5	25	12	12	125	19.5		13	M4x16.1x5.4	
●	●	ZTER/L-1616K-MGX20A-16	32	16	16	125	25		16.5		



●:庫存 In Stock ○:非標準庫存(請確認交貨期) Non-standard Stock

刀片 Insert : KORLOY

Stock		型號 Model No.	D	A	B=H	L	L1	T	T-Max	 螺絲 Screw	 板手 Wrench
R	L										
●	●	ZTER/L-1212K-TD2SH-24	24	12	12	125	19	2	12	M4x16.1x5.4	T15
●	●	ZTER/L-1616K-TD2SH-32	32	16	16	125	24		16	M4x20.0x5.4	

●:庫存 In Stock ○:非標準庫存(請確認交貨期) Non-standard Stock

刀片 Insert : Taegu Tec

Stock		型號 Model No.	D	A	B=H	L	L1	T	T-Max	 螺絲 Screw	 板手 Wrench
R	L										
●	●	ZTER/L-1212K-DGN2-12.5	12.5	12	12	125	19.5	2	12	M4x16.1x5.4	T15
●	●	ZTER/L-1616K-DGN2-16	16	16	16	125	25		16	M4x20.0x5.4	

●:庫存 In Stock ○:非標準庫存(請確認交貨期) Non-standard Stock

刀片 Insert : ISCAR

Zy 外徑端面切槽刀架 External Face Grooving

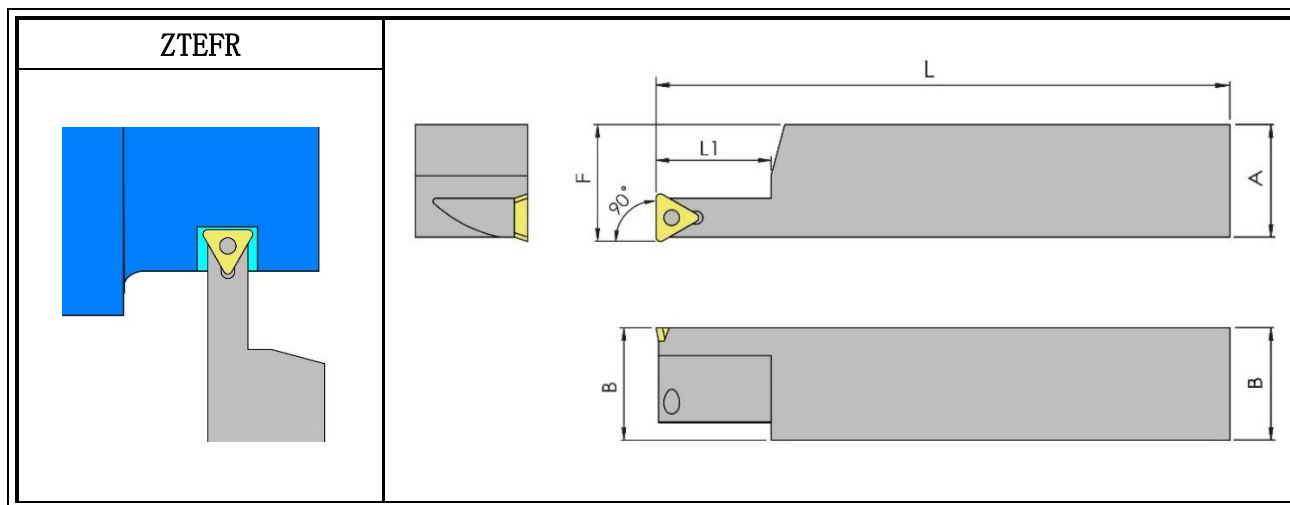



Stock	型號 Model No.	A	B	F	L	L1	螺絲 Screw	扳手 Wrench	刀片 Insert
●	ZTEFR-50/100 2525M-TP09-20	25	25	25.8	150	20	M2.5x6.0x3.6	T15	TP0902
●	ZTEFR-50/100 2525M-TP11-20	25	25	25	150	20	M3x7.8x4.1	T9	TP1103

●:庫存 In Stock ○:非標準庫存(請確認交貨期) Non-standard Stock

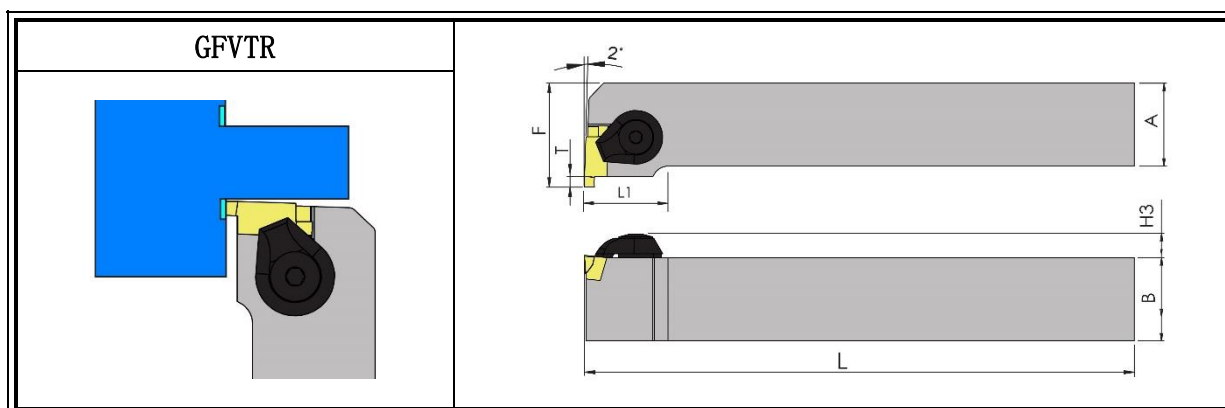
Zy 外徑端面切槽刀架 External Face Grooving



Stock	型號 Model No.	A	B	F	L	L1	T	H3	 螺絲 Screw	 板手 Wrench	刀片 Insert
●	GFVTR-1212K-08AA	12	12	16	125	16	2.2	5.5	GCPA-0513 GCPC0514-51	T20	GVFL100AA GVFL300AA
●	GFVTR-1616K-08AA	16	16	20	125						
●	GFVTR-2020K-08AA	20	20	25	125						
●	GFVTR-2525M-08AA	25	25	32	150						



●:庫存 In Stock ○:非標準庫存(請確認交貨期) Non-standard Stock

刀片 Insert : Kyocera (京瓷)

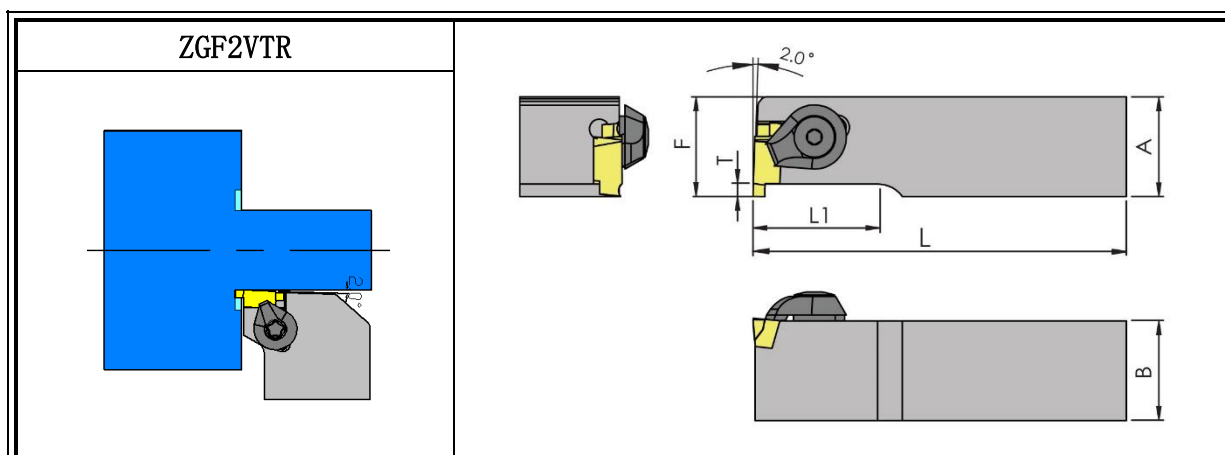

Zy 走心式外徑端面切槽刀架 External Face Grooving For Automatic Lathes



Stock	型號 Model No.	A	B	F	L	L1	T	 螺絲 Screw	 板手 Wrench	刀片 Insert
●	ZGF2VTR-1010K-08AA	10	10	10	125	20	2.2	GCPA-0513 GCPC0514-51	T20	GVFL100AA GVFL300AA
●	ZGF2VTR-1212K-08AA	12	12	12	125					
●	ZGF2VTR-1616K-08AA	16	16	16	125					

●:庫存 In Stock ○:非標準庫存(請確認交貨期) Non-standard Stock

刀片 Insert : Kyocera (京瓷)

Zy 模組化內徑切槽刀頭 Modular Internal Grooving Head With Coolant

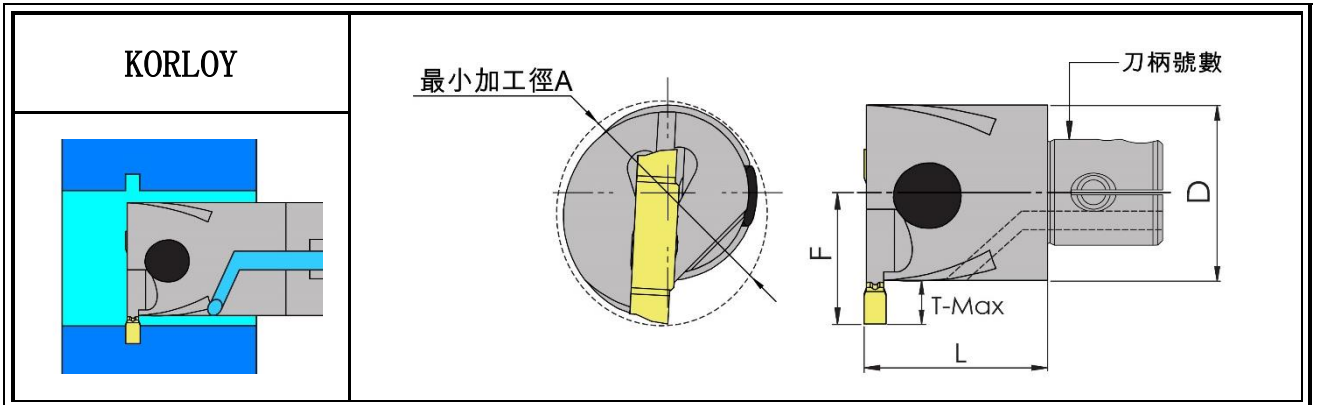

Stock	型號 Model No.	最小加工徑 A	F	D	L	T-Max	S	螺絲 Screw	板手 Wrench
●	SCK1-A2720-MG2-6	27	14	20	24	4.5	24	M5	P4.0
●	SCK1-A2720-MG3-6	27	15.6	20	24	5	25.6		
●	SCK1-A2720-MG4-6	27	15.6	20	24	6	25.6		
●	SCK2-A3225-MG4-6	32	18.9	25	25	6	31.4		
●	SCK2-A3225-MG2-6	32	17.2	25	25	4.5	29.7		
●	SCK2-A3225-MG3-6	32	18.9	25	25	6	31.4		

●:庫存 In Stock ○:非標準庫存(請確認交貨期) Non-standard Stock

刀片 Insert : KORLOY

MG2 = MGMN200

MG3 = MGMN300

MG4 = MGMN400

MG5 = MGMN500

Zy 模組化內徑切槽刀頭 Modular Internal Grooving Head With Coolant

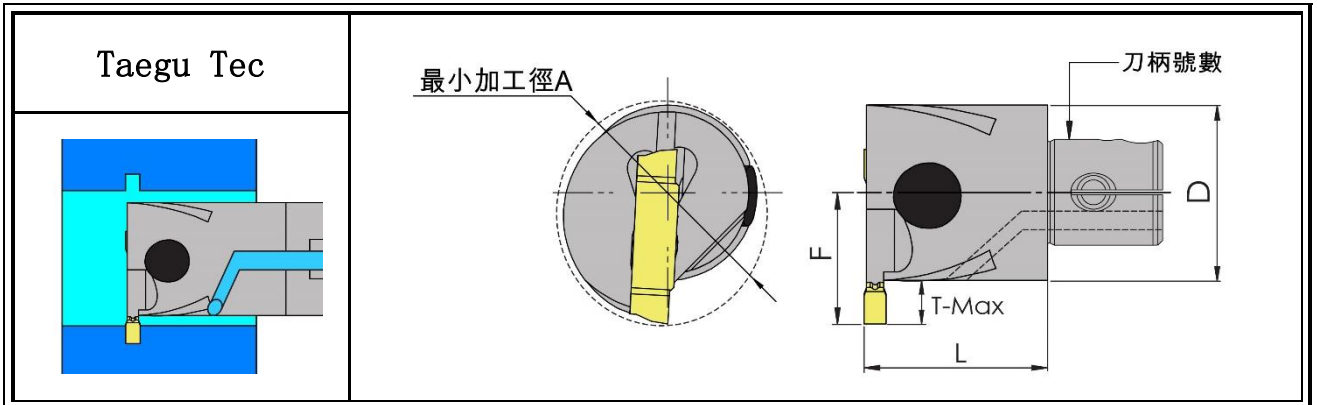

Stock	型號 Model No.	最小加工徑 A	F	D	L	T	S	螺絲 Screw	板手 Wrench
○	SCK1-A2720-TD2-6	27	15.8	20	24	6	25.8	M5	P4.0
○	SCK1-A2720-TD3-6	27	15.8	20	24	6	25.8		
○	SCK2-A3225-TD2-6	32	17.5	25	25	5	30		
○	SCK2-A3225-TD3-6	32	17.5	25	25	5.1	30		

●:庫存 In Stock ○:非標準庫存(請確認交貨期) Non-standard Stock

刀片 Insert : Taegu Tec

Zy 模組化內徑端面切槽刀頭 Modular Internal Face Grooving Head With Coolant

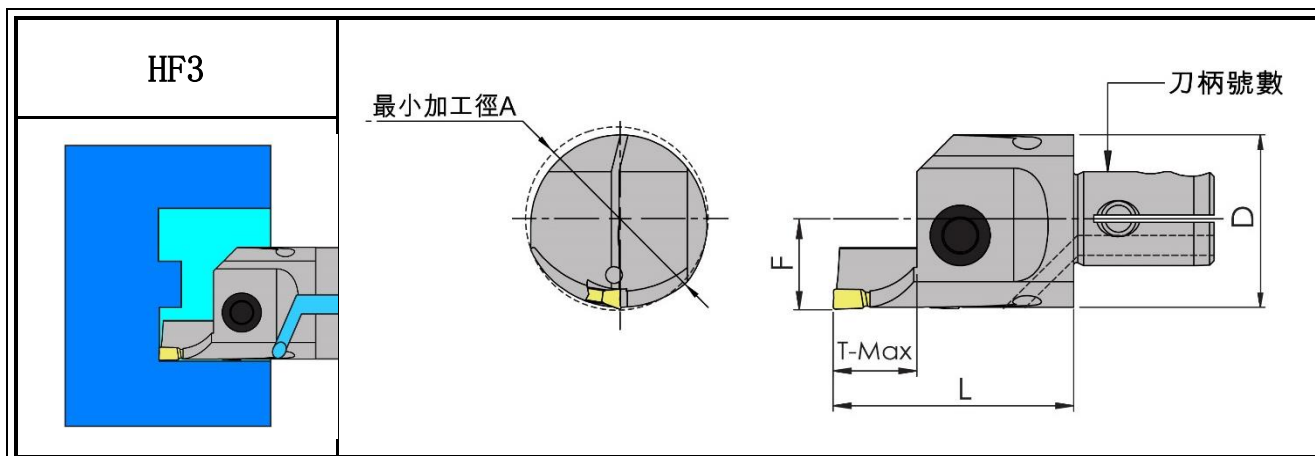

Stock	型號 Model No.	A 最小 A Max	A 最大 A Min	F	D	L	T-Max	螺絲 Screw	板手 Wrench
●	ZTIFR-2530SCK2-HF3-12L	25	30	13.5	25	150	12	HTM5x16L	L4.0
●	ZTIFR-3038SCK2-HF3-12L	30	38		25	150			
●	ZTIFR-3848SCK2-HF3-12L	38	48		25	150			
●	ZTIFR-4860SCK2-HF3-22L	48	60		25	150	22		
●	ZTIFR-6075SCK2-HF3-22L	60	75		25	150			
●	ZTIFR-75100SCK2-HF3-25L	75	100		25	150			

●:庫存 In Stock ○:非標準庫存(請確認交貨期) Non-standard Stock

刀片 Insert : ISCAR

Zy 模組化內徑端面切槽刀頭 Modular Internal Face Grooving Head With Coolant

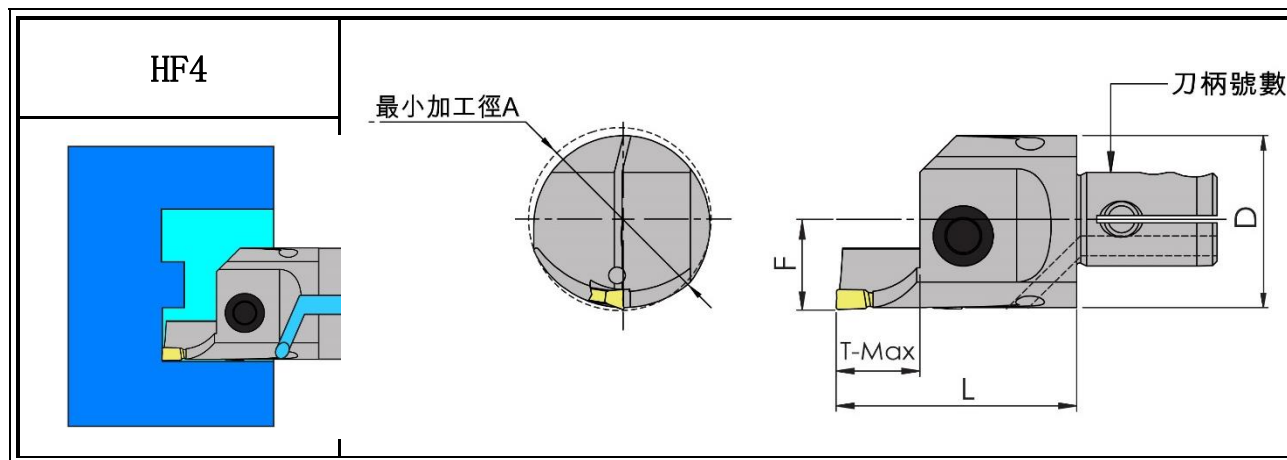

Stock	型號 Model No.	A 最小 A Max	A 最大 A Min	F	D	L	T-Max	螺絲 Screw	板手 Wrench
●	ZTIFR-2529SCK2-HF4-12L	25	29	13.5	25	150	12	HTM5x16L	P4.0
●	ZTIFR-2934SCK2-HF4-12L	29	34		25	150			
●	ZTIFR-3440SCK2-HF4-20L	34	40		25	150	20		
●	ZTIFR-4048SCK2-HF4-25L	40	48		25	150	25		
●	ZTIFR-4860SCK2-HF4-25L	48	60		25	150			
●	ZTIFR-6075SCK2-HF4-25L	60	75		25	150			
●	ZTIFR-75100SCK2-HF4-25L	75	100	25	200				
●	ZTIFR-100140SCK3-HF4-25L	100	140	17	32	200	25	HTM5x16L	P4.0
●	ZTIFR-140240SCK3-HF4-25L	140	240		32	200			
●	ZTIFR-240800SCK3-HF4-25L	240	800		32	200			

●:庫存 In Stock ○:非標準庫存(請確認交貨期) Non-standard Stock

刀片 Insert : ISCAR

Zy 模組化內徑端面切槽刀頭 Modular Internal Face Grooving Head With Coolant

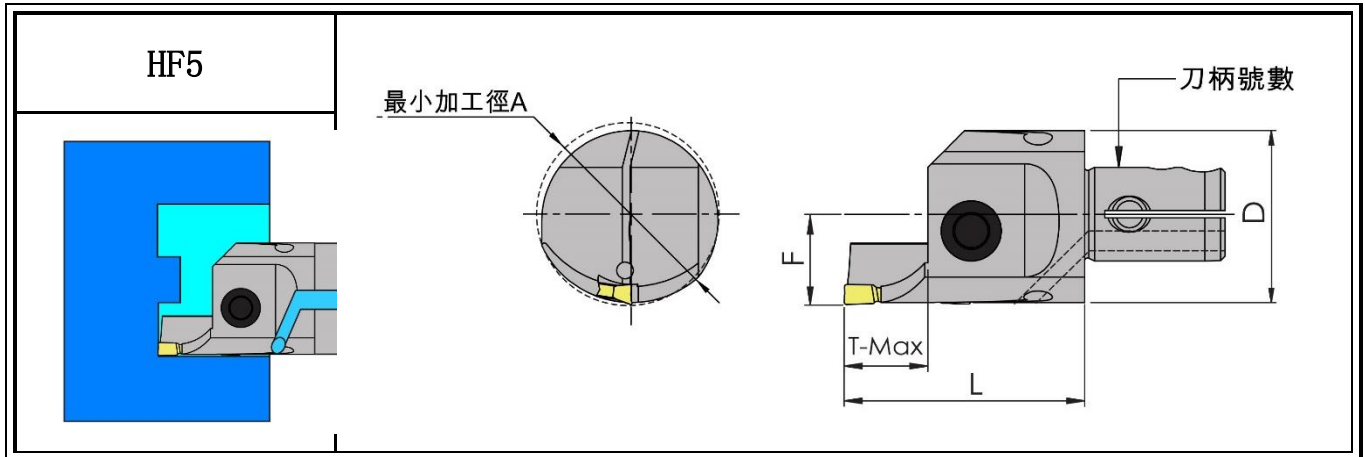

Stock	型號 Model No.	A 最小 A Max	A 最大 A Min	F	D	L	T-Max	螺絲 Screw	板手 Wrench
●	ZTIFR-2529SCK2-HF5-20L	25	29	13.5	25	150	20	HTM5x16L	P4.0
●	ZTIFR-2530SCK2-HF5-12L	25	30		25	150	12		
●	ZTIFR-2831SCK2-HF5-17L	28	31		25	150	17		
●	ZTIFR-3135SCK2-HF5-17L	31	35		25	150	17		
●	ZTIFR-3540SCK2-HF5-20L	32	40		25	150	20		
●	ZTIFR-4045SCK2-HF5-20L	40	45		25	150	20		
●	ZTIFR-4555SCK2-HF5-25L	45	55		25	150	25		
●	ZTIFR-5570SCK3-HF5-25L	55	70	17	32	200	25	HTM5x16L	P4.0
●	ZTIFR-7095SCK3-HF5-25L	70	95		32	200			
●	ZTIFR-95130SCK3-HF5-25L	95	130		32	200			
●	ZTIFR-130180SCK3-HF5-25L	130	180		32	200			
●	ZTIFR-180800SCK3-HF5-25L	180	800		32	200			
●	ZTIFR-200800SCK3-HF5-25L	200	800		32	200			

●:庫存 In Stock ○:非標準庫存(請確認交貨期) Non-standard Stock

刀片 Insert : ISCAR