

外徑車刀



外徑車刀架表示方法

Turning Tool Holders Identification System

A	背面押板緊固方式
C	押板緊固方式
M	雙重緊固方式
P	插銷緊固方式 (槓桿緊固方式)
S	螺絲緊固方式
W	楔型緊固方式
ZS	螺絲緊固方式
刀片緊固方式	

R:圓形
S:90° 四方形
T:60° 三角形
C:80° 菱形
J:70° 菱形
D:55° 菱形
V:35° 菱形
W:80° 不等邊六角形
刀片形狀

R:右手刀 L:左手刀
方向

刀把高度
刀把高度

刀把寬度
刀把寬度

A:32	Q:180
B:40	R:200
C:50	S:250
D:60	T:300
E:70	U:350
F:80	V:400
G:90	W:450
H:100	Y:500
J:110	X:特殊
K:125	
L:140	
M:150	
N:160	
P:170	
刀把全長	

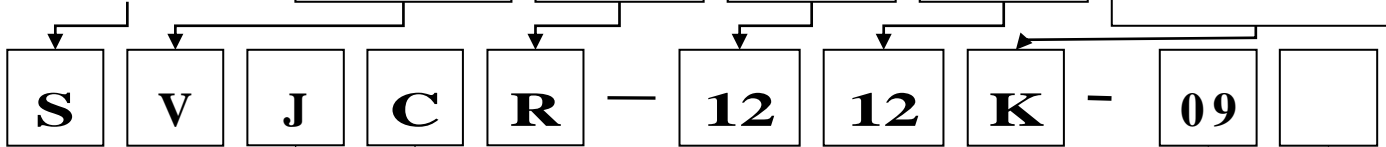

切刃形狀				
A	B	C	D	E
F	G	J	K	L
N	R	S	T	U
W	Y	L2		

刀片後角
B:5° 正角 C:7° 正角 D:15° 正角 E:20° 正角 N:0° 負角 P:11° 正角

切刃長度

任意識別 記號或數 字
其他



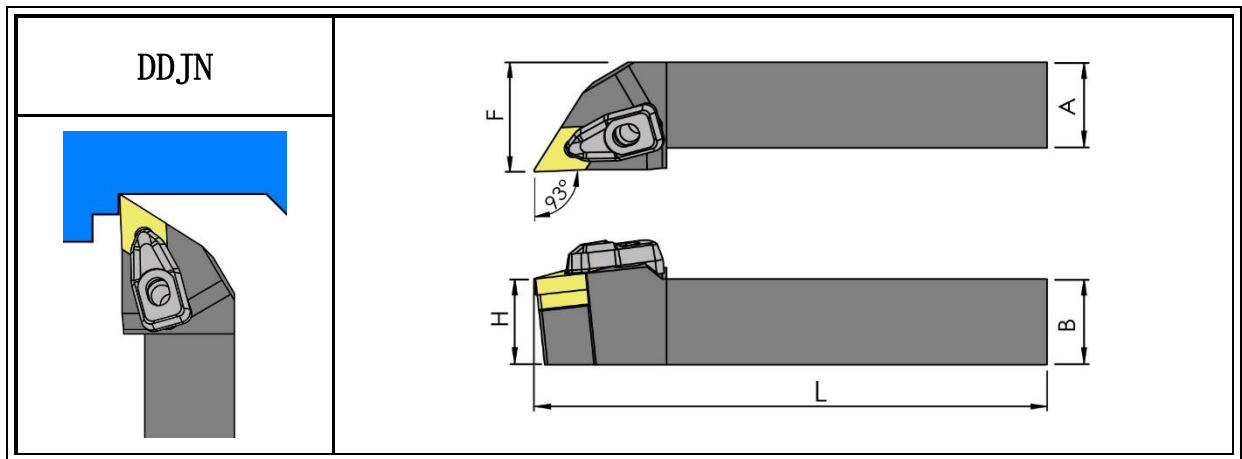

Zy 外徑車刀 Turning Tools

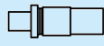

Stock	型號 Model No.	A	B=H	F	L	刀片 Insert
●	DDJNR/L-2020K-15	20	20	25	125	DN1504
●	DDJNR/L-2525M-15	25	25	32	150	

●:庫存 In Stock ○:非標準庫存(請確認交貨期) Non-standard Stock

配件 Tool Parts :

 墊片 Shim	 中心柱 Shim Screw	 壓板 Clamp	 螺絲 Clamp Screw	 彈簧 Spring	 板手 Wrench
DMS442	DDSM4	DDPS-2814	DS625	SP85	L2.5 L3.0



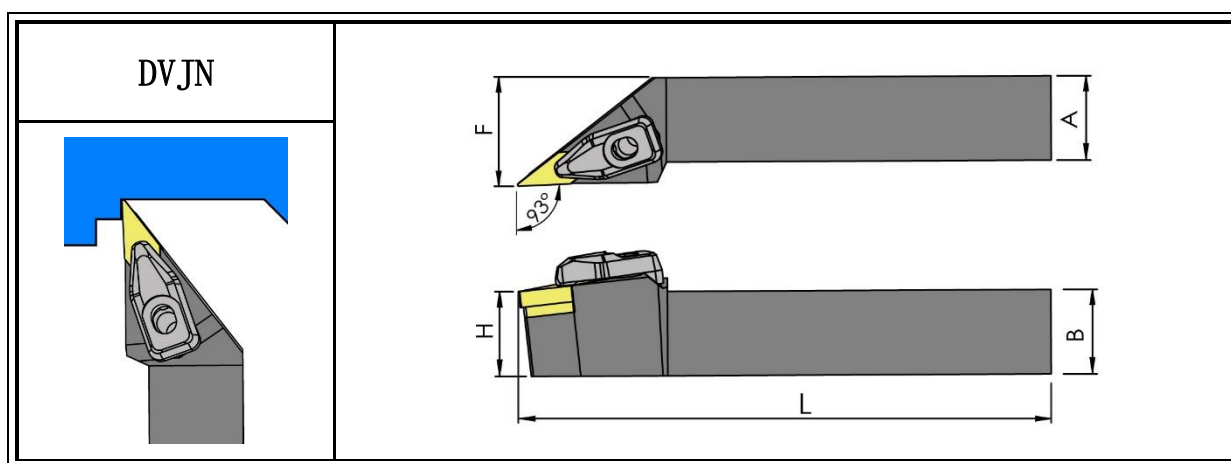

Zy 外徑車刀 Turning Tools

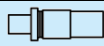

Stock	型號 Model No.	A	B=H	F	L	刀片 Insert
●	DVJNR/L-2020K-16	20	20	25	125	VN1604
●	DVJNR/L-2525M-16	25	25	32	150	

●:庫存 In Stock ○:非標準庫存(請確認交貨期) Non-standard Stock

配件 Tool Parts :

 墊片 Shim	 中心柱 Shim Screw	 壓板 Clamp	 螺絲 Clamp Screw	 彈簧 Spring	 板手 Wrench
GMV322	DVSM4	DVPS-3214	DS625	SP85	L2.5 L3.0



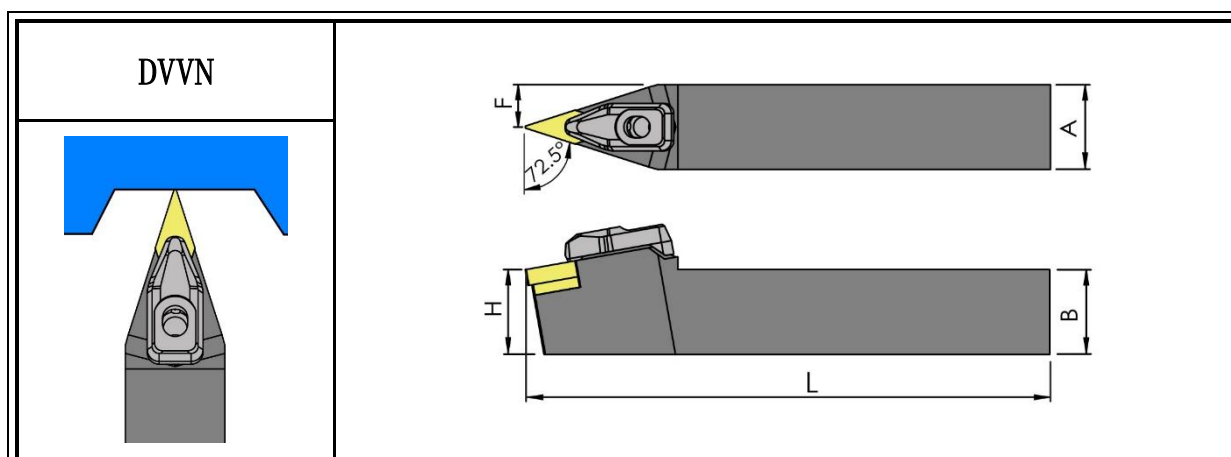

Zy 外徑車刀 Turning Tools

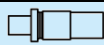

Stock	型號 Model No.	A	B=H	F	L	刀片 Insert
●	DVVN-2020K-16	20	20	25	125	VN1604
●	DVVN-2525M-16	25	25	32	150	

●:庫存 In Stock ○:非標準庫存(請確認交貨期) Non-standard Stock

配件 Tool Parts :

 墊片 Shim	 中心柱 Shim Screw	 壓板 Clamp	 螺絲 Clamp Screw	 彈簧 Spring	 板手 Wrench
GMV322	DVSM4	DVPS-3214	DS625	SP85	L2.5 L3.0



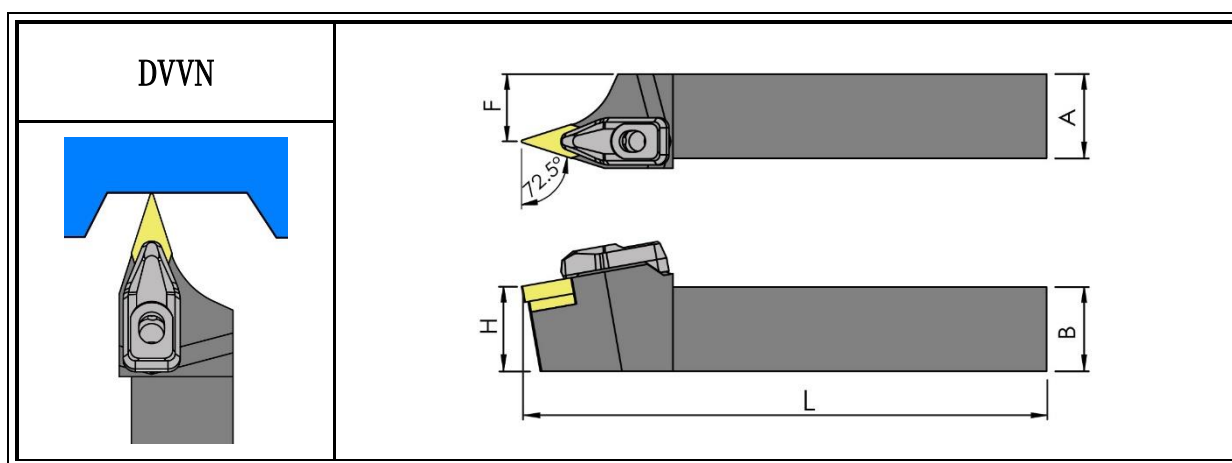

Zy 外徑車刀 Turning Tools



Stock	型號 Model No.	A	B=H	F	L	刀片 Insert
●	DVVNR/L-2020K-16	20	20	25	125	VN1604
●	DVVNR/L-2525M-16	25	25	32	150	

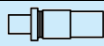

●:庫存 In Stock ○:非標準庫存(請確認交貨期) Non-standard Stock

配件 Tool Parts :

 墊片 Shim	 中心柱 Shim Screw	 壓板 Clamp	 螺絲 Clamp Screw	 彈簧 Spring	 板手 Wrench
GMV322	DVSM4	DVPS-3214	DS625	SP85	L2.5 L3.0

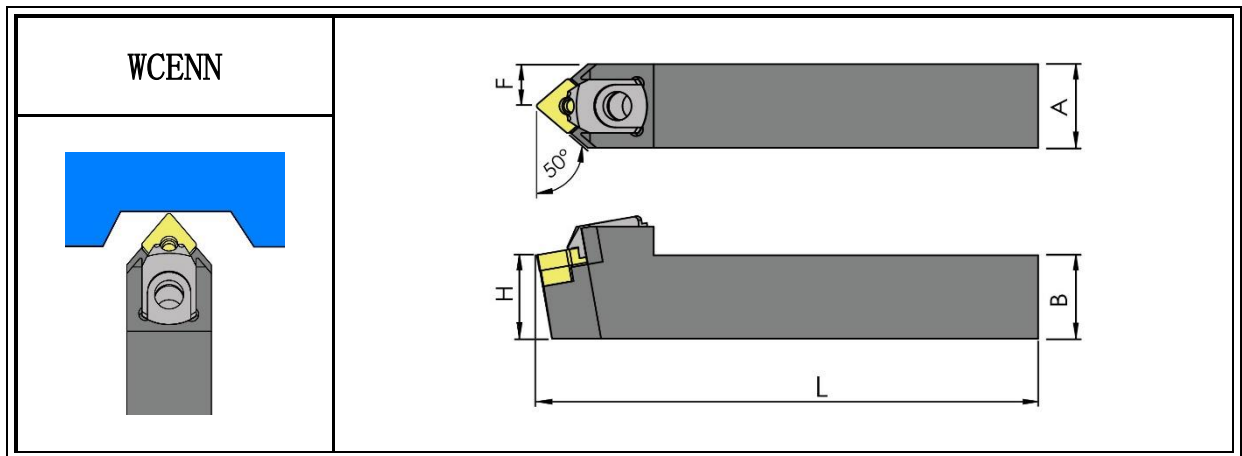

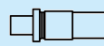

Zy 外徑車刀 Turning Tools

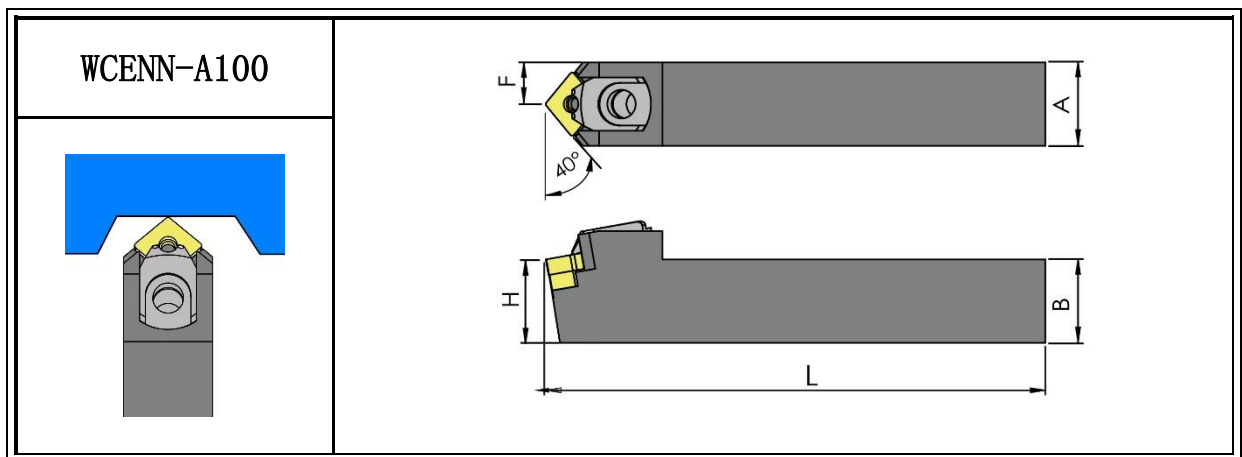

Stock	型號 Model No.	A	B=H	F	L	 墊片 Shim	 中心柱 Shim Screw	 W 型壓板組 W Type Clamp	 板手 Wrench	刀片 Insert
●	WCENN-2020K-12	20	20	10	125	CMS422	LCS-618A	WCPS-2516A	L3.0	CN1204
●	WCENN-2525M-12	25	25	12.5	150				L4.0	

●:庫存 In Stock ○:非標準庫存(請確認交貨期) Non-standard Stock



Stock	型號 Model No.	A	B=H	F	L	 墊片 Shim	 中心柱 Shim Screw	 W 型壓板組 W Type Clamp	 板手 Wrench	刀片 Insert
●	WCENN-2020K-12-A100	20	20	10	125	CMS422	LCS-618A	WCPS-2516A	L3.0	CN1204
●	WCENN-2020K-12-A100	25	25	12.5	150				L4.0	

●:庫存 In Stock ○:非標準庫存(請確認交貨期) Non-standard Stock

Zy 外徑車刀 Turning Tools

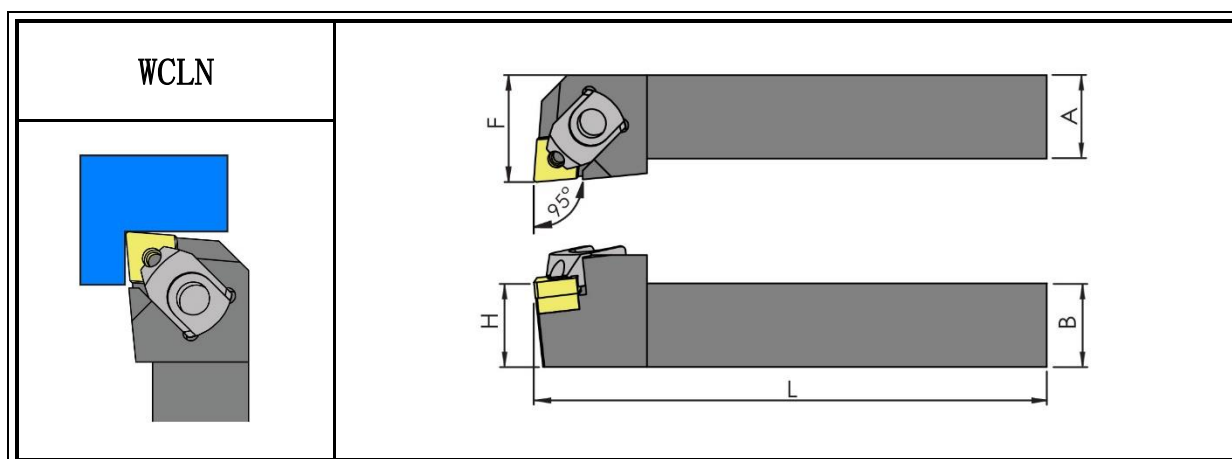

Stock	型號 Model No.	A	B=H	F	L	墊片 Shim	中心柱 Shim Screw	W型壓板組 W Type Clamp	板手 Wrench	刀片 Insert
●	WCLNR/L-2020K-12	20	20	10	125	CMS422	LCS-618A	WCPS-2516A	L3.0	CN1204
●	WCLNR/L-2525M-12	25	25	12.5	150				L4.0	

●:庫存 In Stock ○:非標準庫存(請確認交貨期) Non-standard Stock

Zy 外徑車刀 Turning Tools

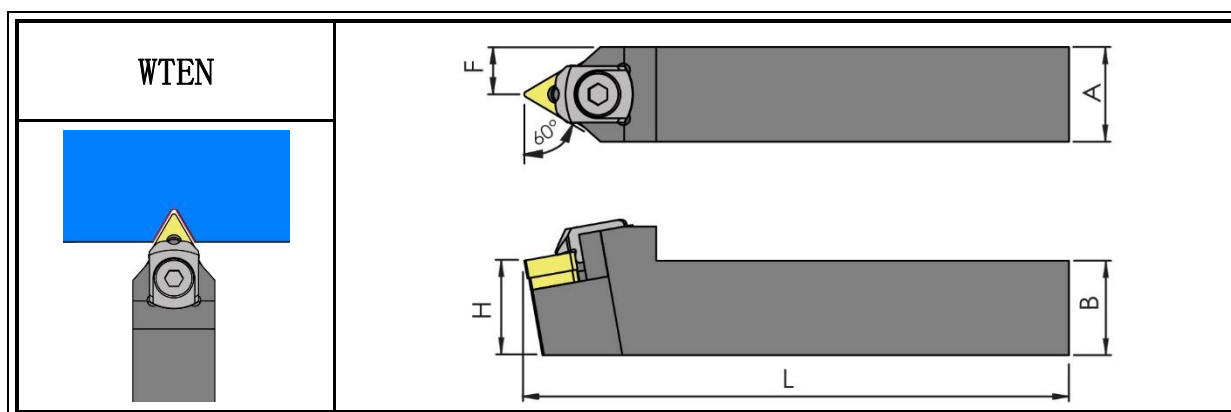

Stock	型號 Model No.	A	B=H	F	L	 墊片 Shim	 中心柱 Shim Screw	 W 型壓板組 W Type Clamp	 板手 Wrench	刀片 Insert
●	WTENN-1616K-16	16	16	8	125	TMS322	LCS-519-1A	WTPS-2115A	L2.5 L4.0	TN1604
●	WTENN-2020K-16	20	20	10	125					
●	WTENN-2525M-16	25	25	12.5	150					
●	WTENN-3232P-16	32	32	16	170					

●:庫存 In Stock ○:非標準庫存(請確認交貨期) Non-standard Stock

Zy 外徑車刀 Turning Tools

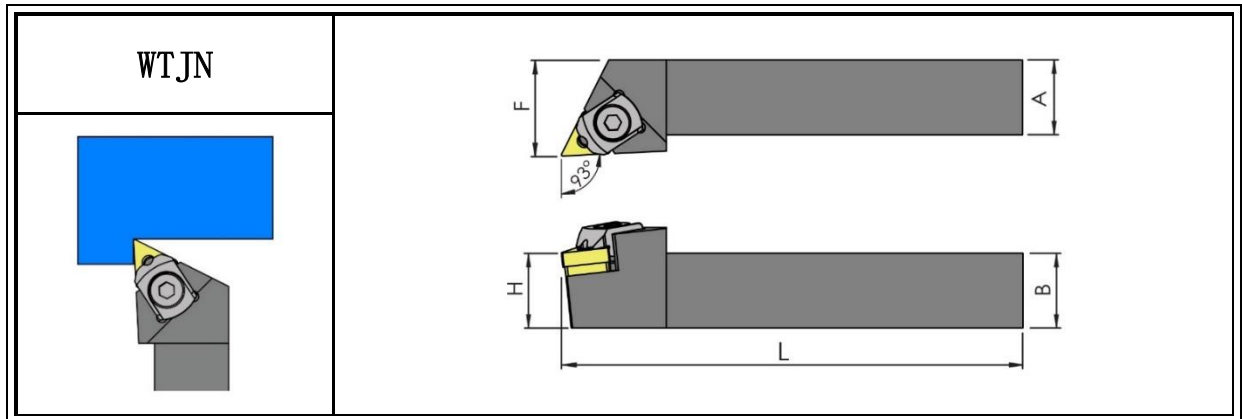

Stock	型號 Model No.	A	B=H	F	L	 墊片 Shim	 中心柱 Shim Screw	 W 型壓板組 W Type Clamp	 板手 Wrench	刀片 Insert
●	WTJNR/L-2020K-16	20	20	25	125	TMS322	LCS-519-1A	WTPS-2115A	L2.5 L4.0	TN1604
●	WTJNR/L-2525M-16	25	25	32	150					
●	WTJNR/L-3232P-16	32	32	40	170					

●:庫存 In Stock ○:非標準庫存(請確認交貨期) Non-standard Stock

Zy 外徑車刀 Turning Tools

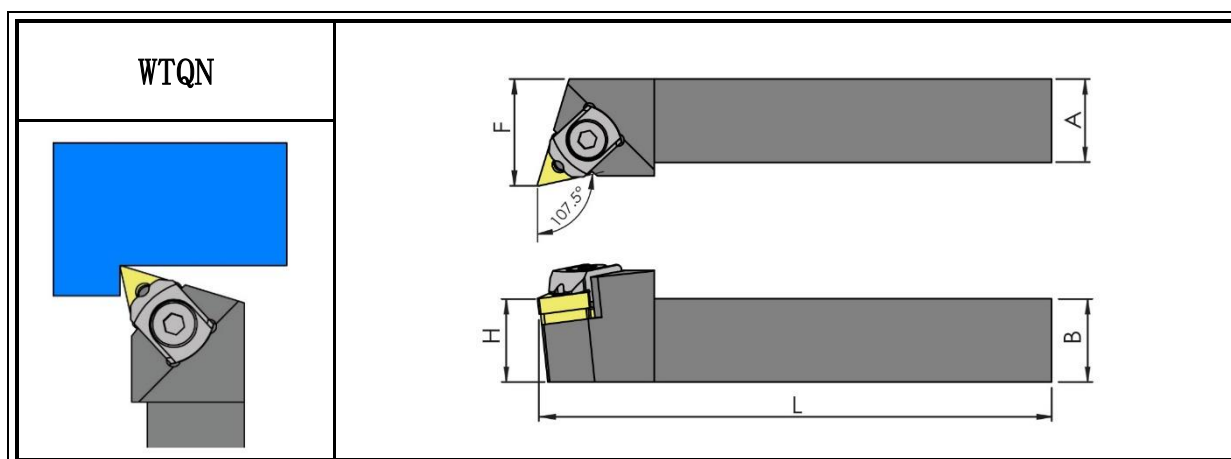

Stock	型號 Model No.	A	B=H	F	L	 墊片 Shim	 中心柱 Shim Screw	 W 型壓板組 W Type Clamp	 板手 Wrench	刀片 Insert
●	WTQNR/L-2020K-16	20	20	25	125	TMS322	LCS-519-1A	WTPS-2115A	L2.5 L4.0	TN1604
●	WTQNR/L-2525M-16	25	25	32	150					

●:庫存 In Stock ○:非標準庫存(請確認交貨期) Non-standard Stock

Zy 外徑車刀 Turning Tools

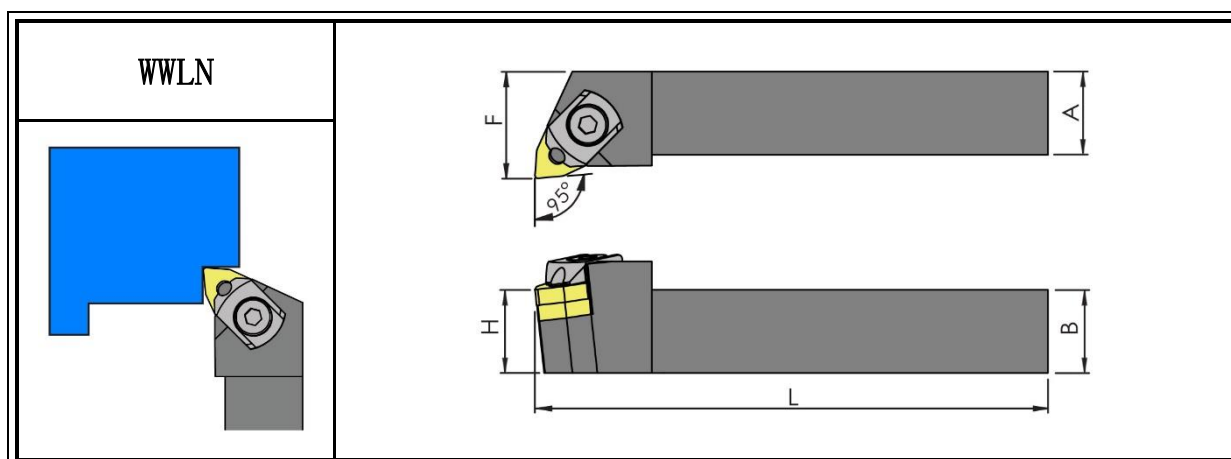

Stock	型號 Model No.	A	B=H	F	L	 墊片 Shim	 中心柱 Shim Screw	 W 型壓板組 W Type Clamp	 板手 Wrench	刀片 Insert
●	WWLNR/L-2020K-08	20	20	25	125	WMS422	LCS-618A	WWPS-2316A	L3.0	WN0804
●	WWLNR/L-2525M-08	25	25	32	150				L4.0	

●:庫存 In Stock ○:非標準庫存(請確認交貨期) Non-standard Stock

Zy 外徑車刀 Turning Tools

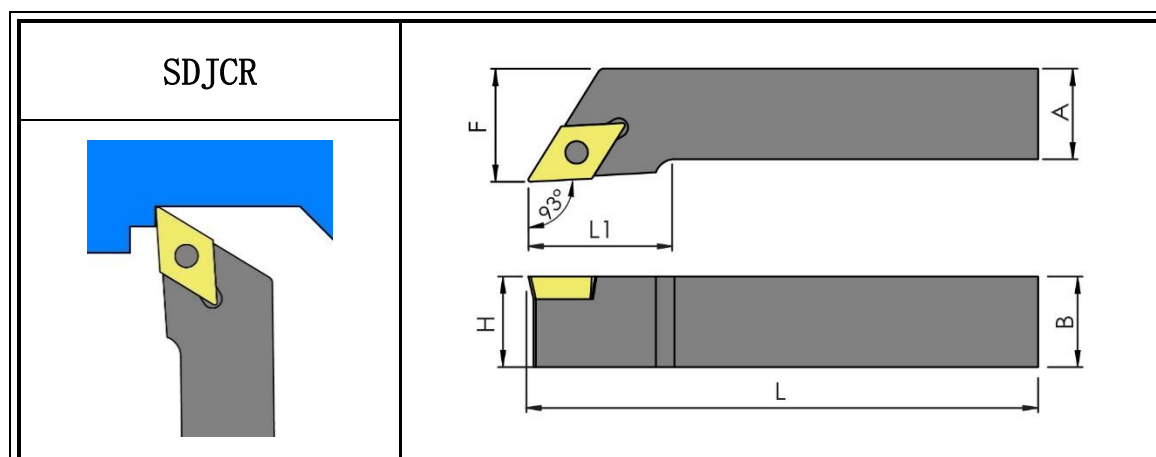

Stock	型號 Model No.	A	B=H	F	L	L1	螺絲 Screw	板手 Wrench	刀片 Insert
●	SDJCR-1010H-07	10	10	12	100	14	M2.5x6.0x3.6	T8	DC0702
○	SDJCR-1212K-07	12	12	16	125	14			
●	SDJCR-1010H-11	10	10	12	100	22	M4x8.8x5.4	T15	DC11T3
●	SDJCR-1212K-11	12	12	16	125	22			
●	SDJCR-1616K-11	16	16	20	125	22			
●	SDJCR-2020K-11	20	20	25	125	22			
●	SDJCR-2525M-11	25	25	32	150	25			

●:庫存 In Stock ○:非標準庫存(請確認交貨期) Non-standard Stock

Zy 外徑車刀 Turning Tools

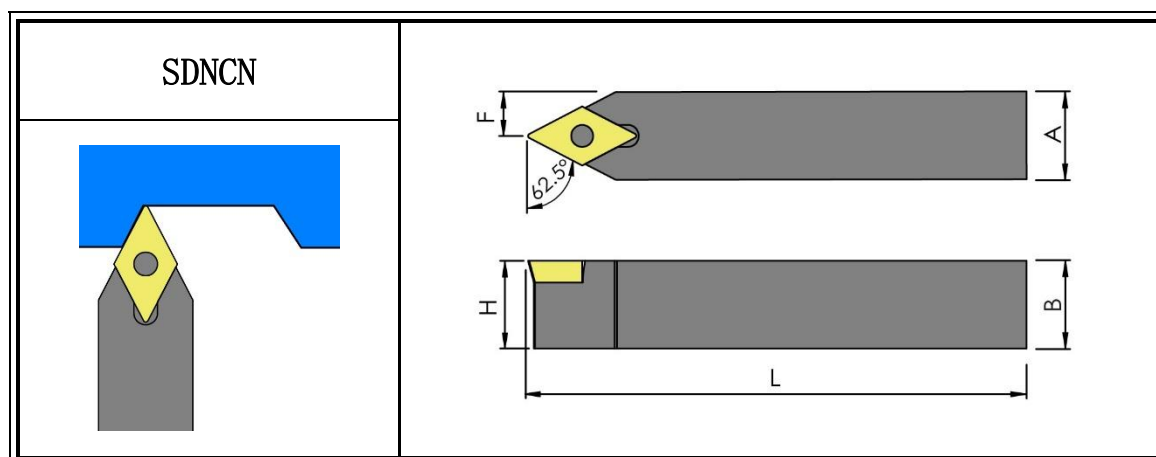

Stock	型號 Model No.	A	B=H	F	L	螺絲 Screw	扳手 Wrench	刀片 Insert
○	SDNCN-0808H-07	8	8	4	100	M2.5x6.0x3.6	T8	DC0702
●	SDNCN-1010H-07	10	10	5	100			
●	SDNCN-1212K-07	12	126	6	125			
●	SDNCN-1212K-11	12	12	6	125	M4x8.8x5.4	T15	DC11T3
●	SDNCN-1616K-11	16	16	8	125			
●	SDNCN-2020K-11	20	20	10	125			
●	SDNCN-2525M-11	25	25	12.5	150			

●:庫存 In Stock ○:非標準庫存(請確認交貨期) Non-standard Stock

Zy 外徑車刀 Turning Tools

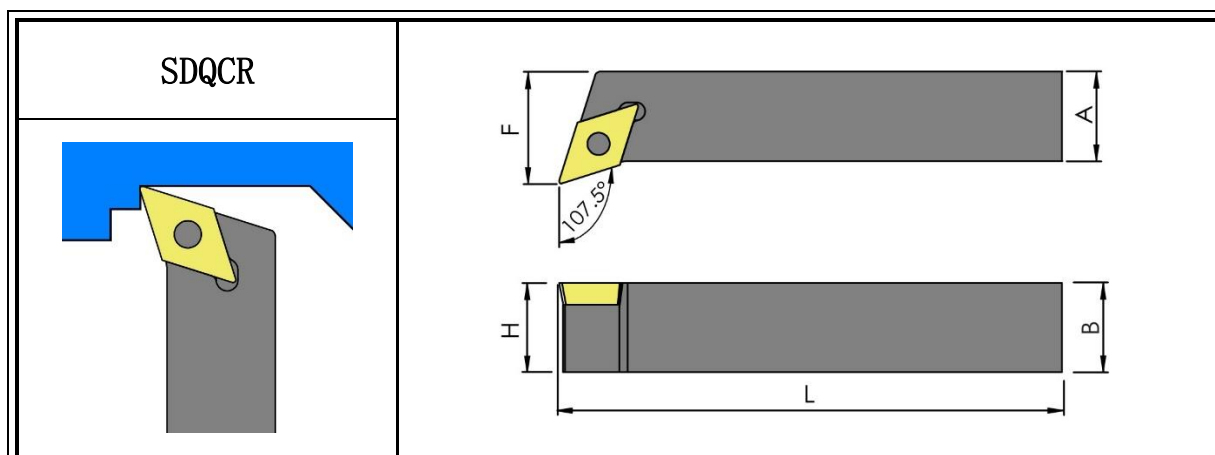

Stock	型號 Model No.	A	B=H	F	L	螺絲 Screw	板手 Wrench	刀片 Insert
●	SDQCR-1010K-07	10	10	12	100	M2.5x6.0x3.6	T8	DC0702
○	SDQCR-1212K-07	12	12	16	125			
●	SDQCR-1212K-11	12	12	16	125	M4x8.8x5.4	T15	DC11T3
●	SDQCR-1616K-11	16	16	20	125			
●	SDQCR-2020K-11	20	20	25	125			
●	SDQCR-2525M-11	25	25	32	150			

●:庫存 In Stock ○:非標準庫存(請確認交貨期) Non-standard Stock

Zy 外徑車刀 Turning Tools

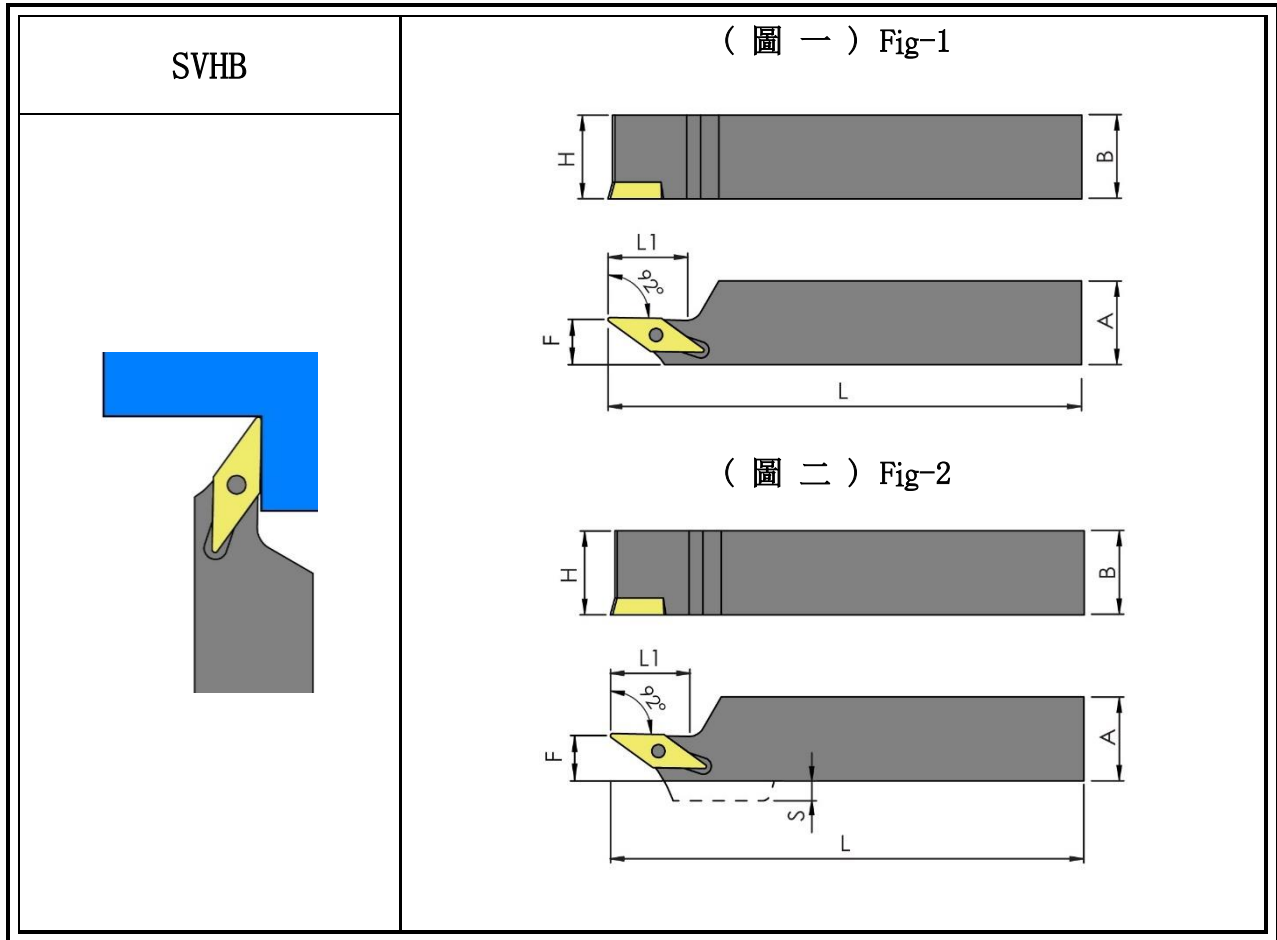

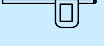
Stock	型號 Model No.	A	B=H	L	L1	S	圖 Fig	 螺絲 Screw	 板手 Wrench	刀片 Insert
●	SVHBL-1010K-11	10	10	125	15	-	1	M2.5x6.0x3.6	T8	VB1103
●	SVHBL-1212K-11	12	12	125	15	-				
●	SVHBL-1616K-11	16	16	125	15	-				
●	SVHBL-2020K-11	20	20	125	19	-				
●	SVHBL-2525M-11	25	25	150	19	-				
●	SVHBL-2525M-11-9.51	25	25	150	19	5	2			

●:庫存 In Stock ○:非標準庫存(請確認交貨期) Non-standard Stock

Zy 外徑車刀 Turning Tools

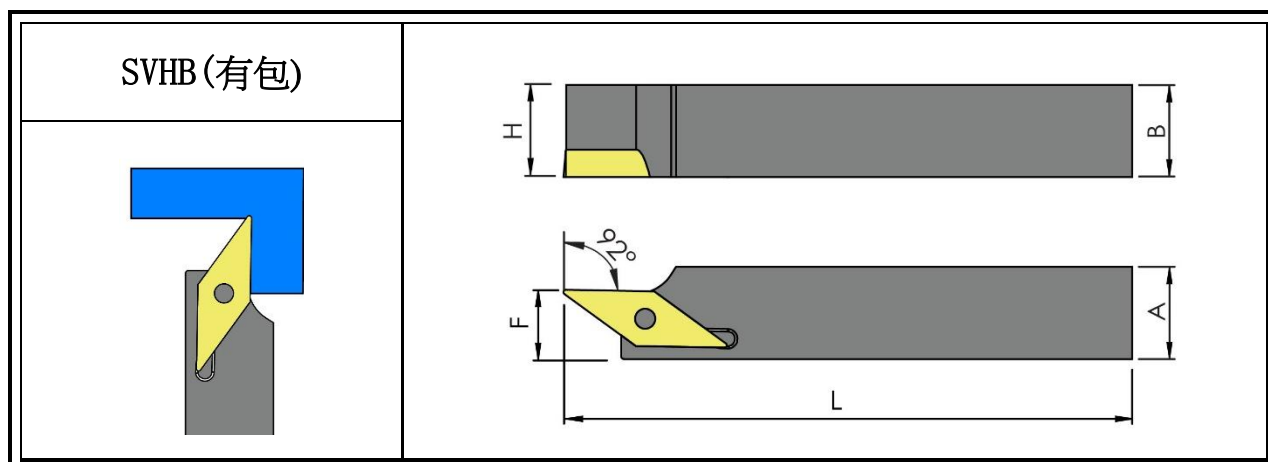

Stock	型號 Model No.	A	B=H	L	F	螺絲 Screw	扳手 Wrench	刀片 Insert
●	SVHBL-1616K-16ALB	16	16	125	12	M3.5x12.0x5.4	T15	VB1604
●	SVHBL-2020K-16ALB	20	20	125	12			
●	SVHBL-2525M-16ALB	25	25	150	12			

●:庫存 In Stock ○:非標準庫存(請確認交貨期) Non-standard Stock

Zy 外徑車刀 Turning Tools

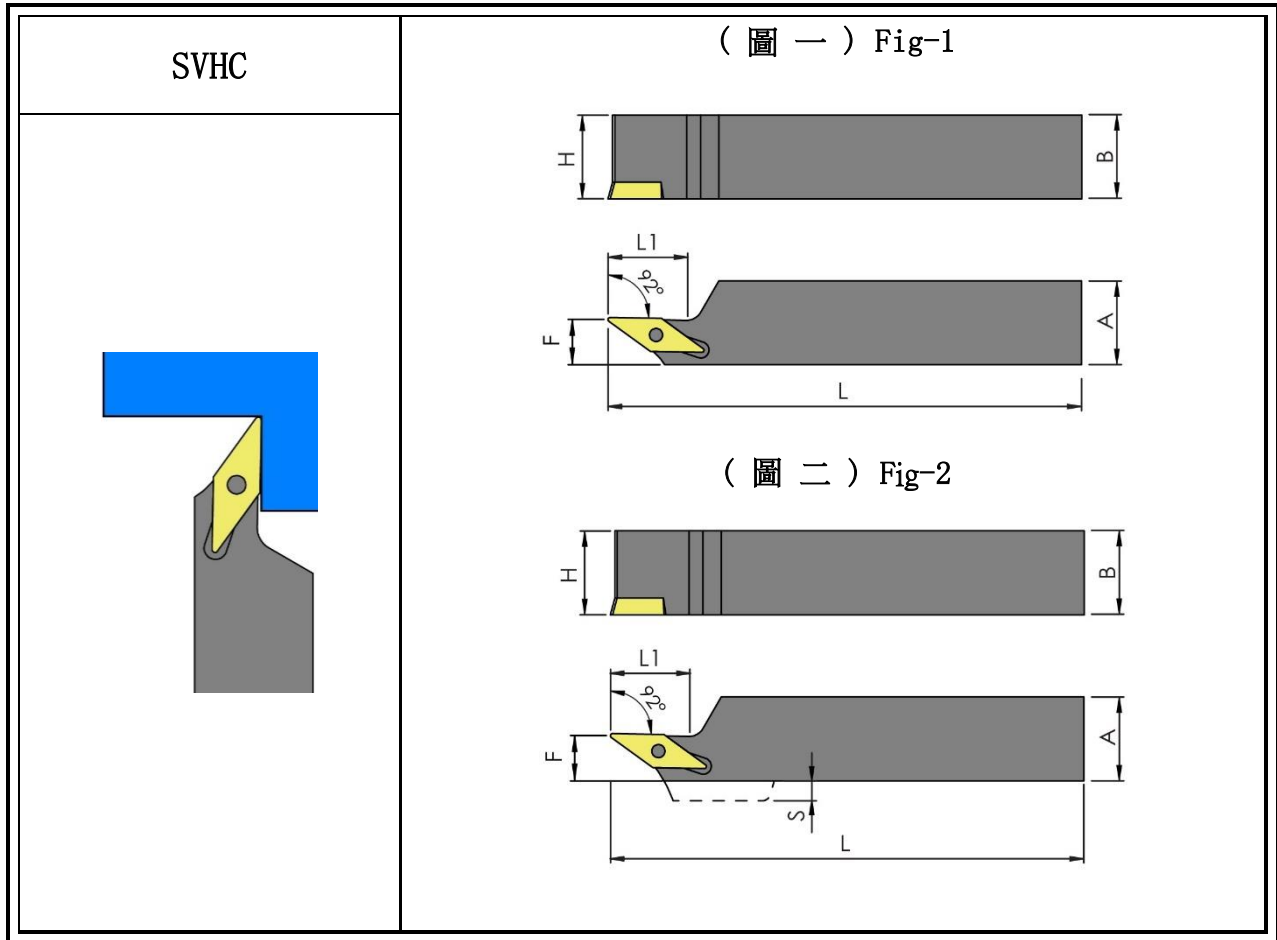

Stock	型號 Model No.	A	B=H	L	L1	S	圖 Fig	螺絲 Screw	扳手 Wrench	刀片 Insert
●	SVHCL-1010K-11	10	10	125	15	-	1	M2.5x6.0x3.6	T8	VC1103
●	SVHCL-1212K-11	12	12	125	15	-				
●	SVHCL-1616K-11	16	16	125	15	-				
●	SVHCL-2020K-11	20	20	125	19	-				
●	SVHCL-2525M-11	25	25	150	19	-				
●	SVHCL-2525M-11-9.51	25	25	150	19	5	2			

●:庫存 In Stock ○:非標準庫存(請確認交貨期) Non-standard Stock

Zy 外徑車刀 Turning Tools

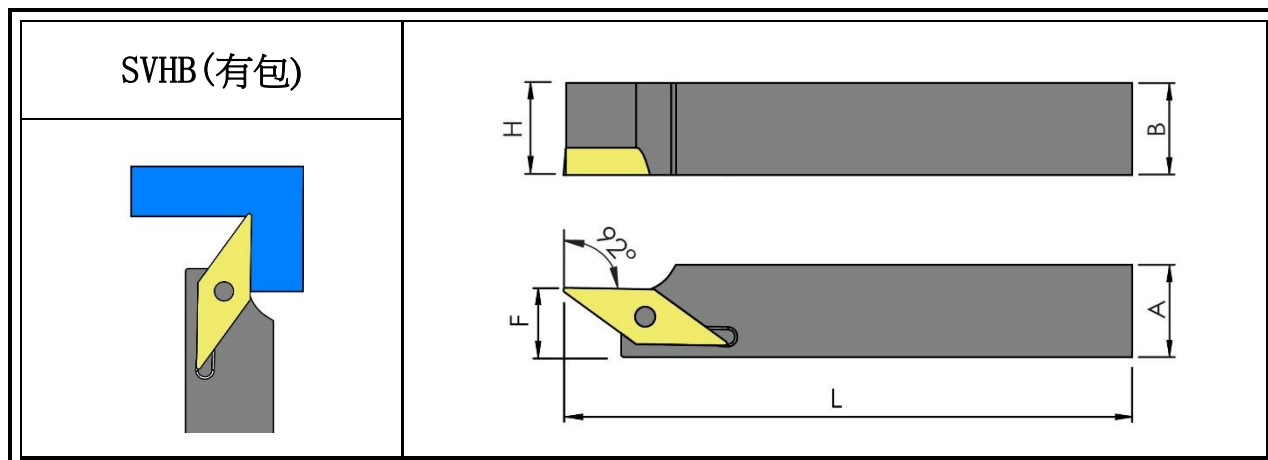



Stock	型號 Model No.	A	B=H	L	F	螺絲 Screw	板手 Wrench	刀片 Insert
●	SVHBL-1616K-16ALB	16	16	125	12	M3.5x12.0x5.4	T15	VB1604
●	SVHBL-2020K-16ALB	20	20	125	12			
●	SVHBL-2525M-16ALB	25	25	150	12			

●:庫存 In Stock ○:非標準庫存(請確認交貨期) Non-standard Stock

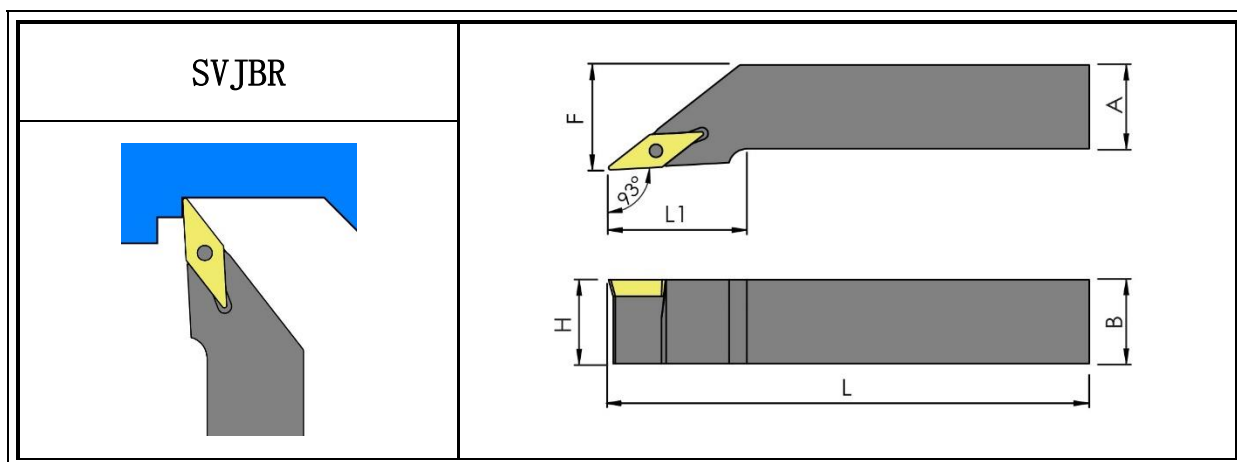
Zy 外徑車刀 Turning Tools

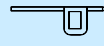

Stock	型號 Model No.	A	B=H	F	L	L1	 墊片 Shim	 墊片 螺絲 Shim Screw	 螺絲 Screw	 板手 Wrench	刀片 Insert
●	SVJBR-1010H-11	10	10	12	100	20	-	-	M2.5x6.0x3.6	T8	VB1103
●	SVJBR-1212K-11	12	12	16	125	22					
●	SVJBR-1616K-11	16	16	20	125	22					
●	SVJBR-2020K-11	20	20	25	125	32					
●	SVJBR-2525M-11	25	25	32	150	32					
●	SVJBR-1616K-16	16	16	20	125	32	VSS322	M5	M3.5x11.4x5.7	T15 L:3.5	VB1604
●	SVJBR-2020K-16	20	20	25	125	32					
●	SVJBR-2525M-16	25	25	32	150	32					

●:庫存 In Stock ○:非標準庫存(請確認交貨期) Non-standard Stock

Zy 外徑車刀 Turning Tools

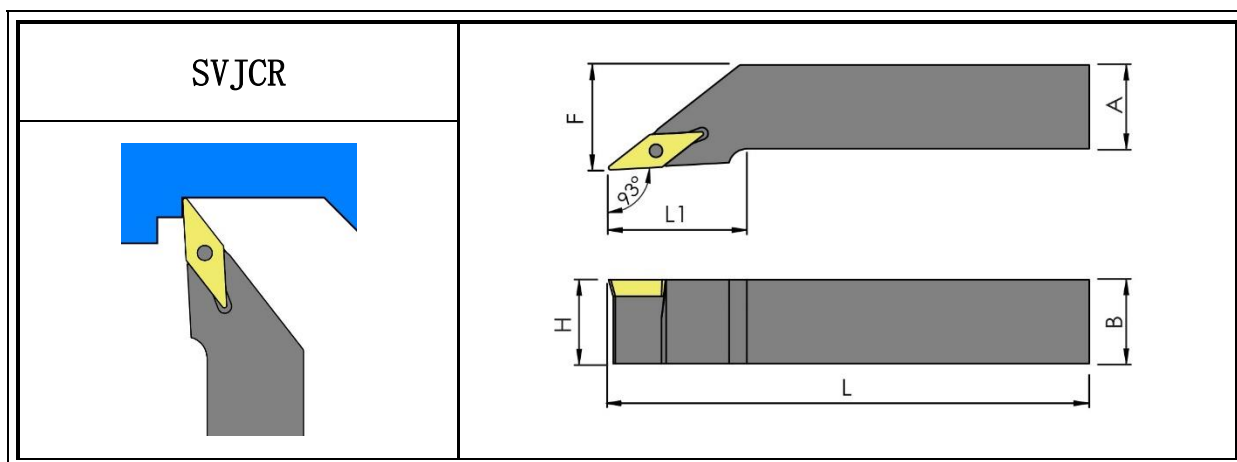

Stock	型號 Model No.	A	B=H	F	L	L1	墊片 Shim	墊片螺絲 Shim Screw	螺絲 Screw	板手 Wrench	刀片 Insert
●	SVJCR-1010H-11	10	10	12	100	20	-	-	M2.5x6.0x3.6	T8	VC1103
●	SVJCR-1212K-11	12	12	16	125	22					
●	SVJCR-1616K-11	16	16	20	125	22					
●	SVJCR-2020K-11	20	20	25	125	32					
●	SVJCR-2525M-11	25	25	32	150	32					
●	SVJCR-1616K-16	16	16	20	125	32	VSS322	M5	M3.5X11.4X5.7	T15 L:3.5	VC1604
●	SVJCR-2020K-16	20	20	25	125	32					
●	SVJCR-2525M-16	25	25	32	150	32					

●:庫存 In Stock ○:非標準庫存(請確認交貨期) Non-standard Stock

Zy 外徑車刀 Turning Tools

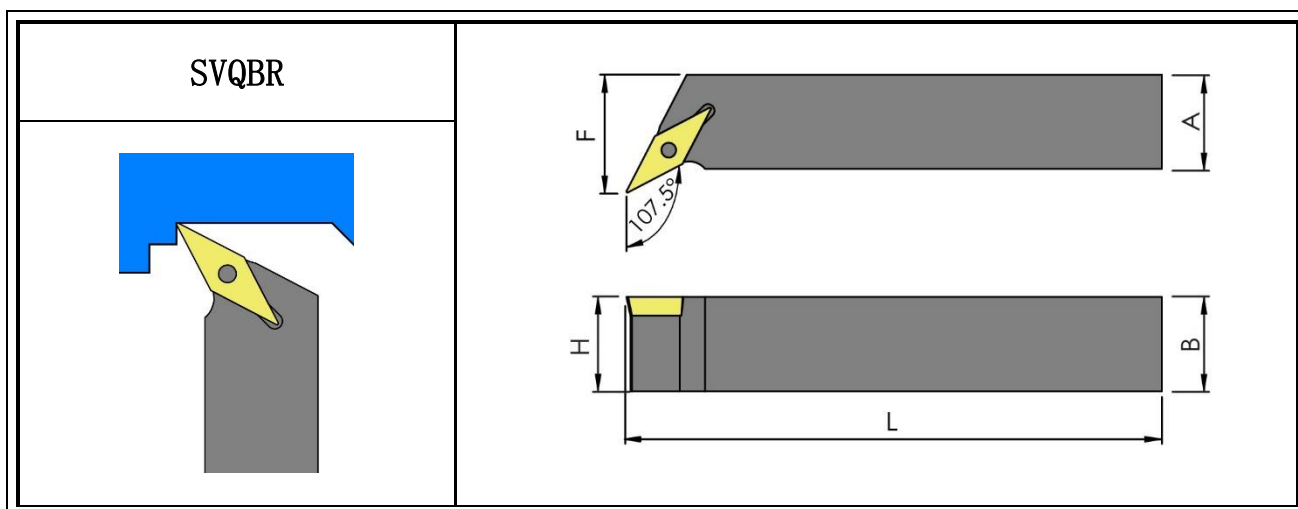

Stock	型號 Model No.	A	B=H	F	L	墊片 Shim	墊片 Shim 螺絲 Screw	螺絲 Screw	板手 Wrench	刀片 Insert
●	SVQBR-1212K-11	12	12	16	125					
●	SVQBR-1616K-11	16	16	20	125	-	-	M2.5x6.0x3.6	T8	VB1103
●	SVQBR-2020K-11	20	20	25	125					
●	SVQBR-1616K-16	16	16	20	125	-	-	M3.5x12.0x5.4	T15	VB1604
●	SVQBR-2020K-16	20	20	25	125	VSS322	M5	M3.5x11.4x5.7	T15	
●	SVQBR-2525M-16	25	25	32	150				L:3.5	

●:庫存 In Stock ○:非標準庫存(請確認交貨期) Non-standard Stock

Zy 外徑車刀 Turning Tools

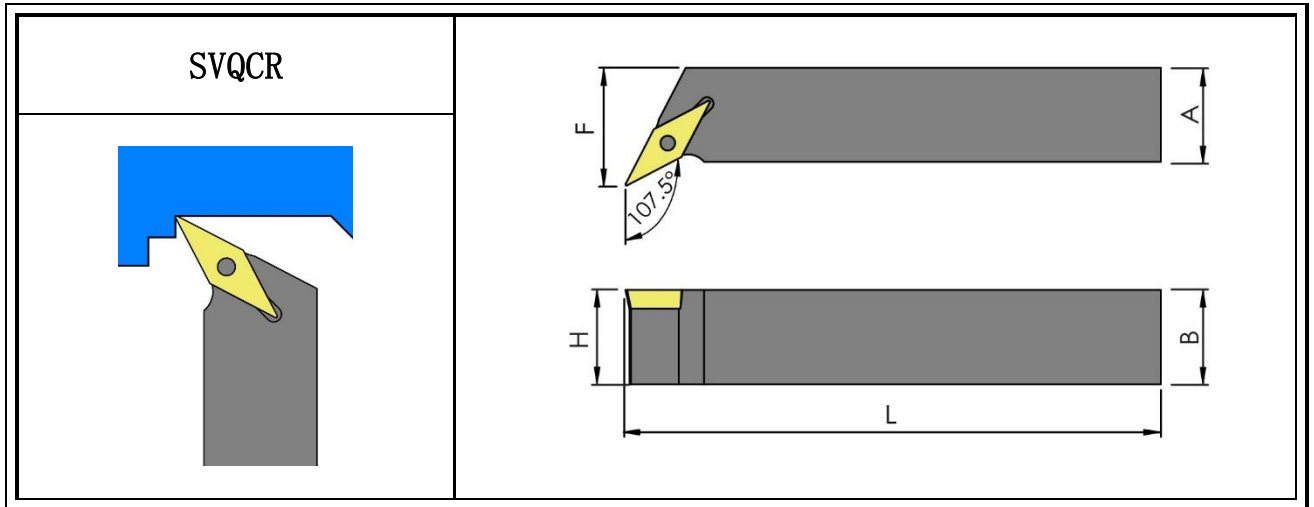

Stock	型號 Model No.	A	B=H	F	L	墊片 Shim	墊片 Shim 螺絲 Screw	螺絲 Screw	板手 Wrench	刀片 Insert
●	SVQCR-1212K-11	12	12	16	125					
●	SVQCR-1616K-11	16	16	20	125	-	-	M2.5x6.0x3.6	T8	VC1103
●	SVQCR-2020K-11	20	20	25	125					
●	SVQCR-1616K-16	16	16	20	125			M3.5x12.0x5.4	T15	VC1604
●	SVQCR-2020K-16	20	20	25	125	VSS322	M5	M3.5x11.4x5.7	T15	
●	SVQCR-2525M-16	25	25	32	150				L:3.5	

●:庫存 In Stock ○:非標準庫存(請確認交貨期) Non-standard Stock

Zy 外徑車刀 Turning Tools

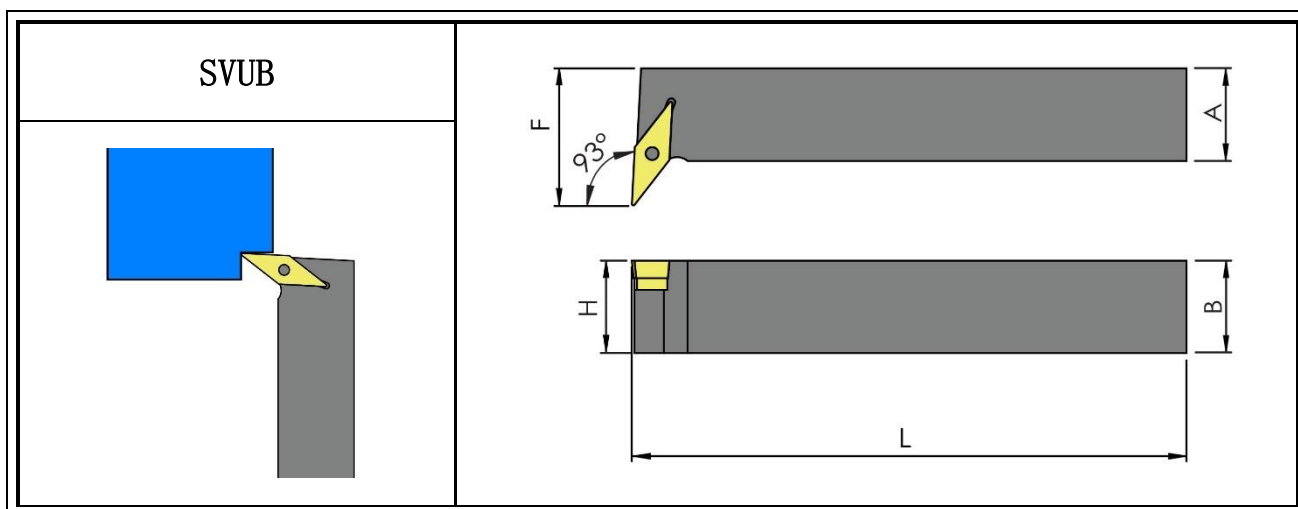

Stock	型號 Model No.	A	B=H	F	L	墊片 Shim	墊片螺絲 Shim Screw	螺絲 Screw	板手 Wrench	刀片 Insert
●	SVUBR/L-2020K-11	20	20	30	125	-	-	M2.5x6.0x3.6	T8	VB1103
●	SVUBR/L-2020K-16	20	20	32	125	VSS322	M5	M3.5x11.4x5.7	T15 L:3.5	VB1604
●	SVUBR/L-2525M-16	25	25	37	150					

●:庫存 In Stock ○:非標準庫存(請確認交貨期) Non-standard Stock

Zy 外徑車刀 Turning Tools

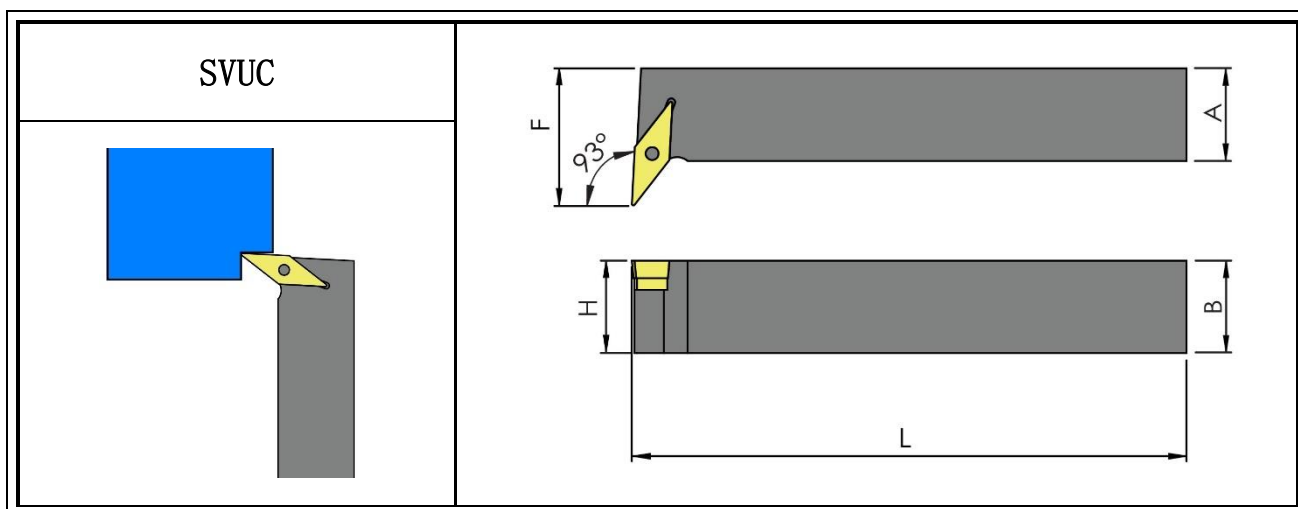

Stock	型號 Model No.	A	B=H	F	L	墊片 Shim	墊片螺絲 Shim Screw	螺絲 Screw	板手 Wrench	刀片 Insert
●	SVUCR/L-2020K-11	20	20	30	125	-	-	M2.5x6.0x3.6	T8	VC1103
●	SVUCR/L-2020K-16	20	20	32	125	VSS322	M5	M3.5x11.4x5.7	T15 L:3.5	VC1604
●	SVUCR/L-2525M-16	25	25	37	150					

●:庫存 In Stock ○:非標準庫存(請確認交貨期) Non-standard Stock

Zy 外徑車刀 Turning Tools

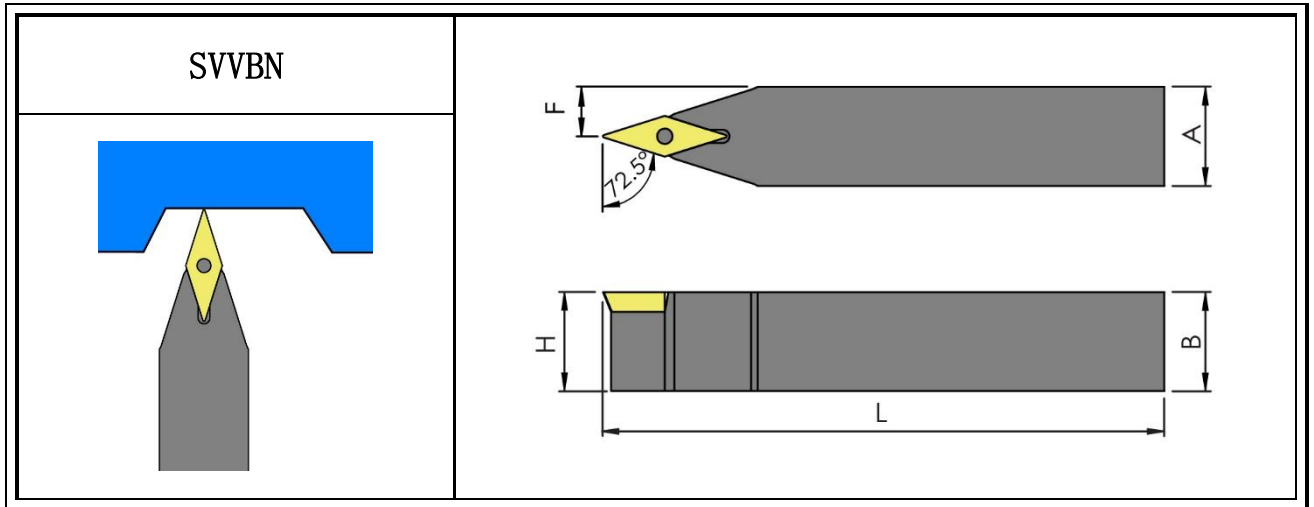

Stock	型號 Model No.	A	B=H	F	L	墊片 Shim	墊片螺絲 Shim Screw	螺絲 Screw	板手 Wrench	刀片 Insert
●	SVVBN-1010H-11	10	10	5	100	-	-	M2.5x6.0x3.6	T8	VB1103
●	SVVBN-1212K-11	12	12	6	125					
●	SVVBN-1616K-11	16	16	8	125					
●	SVVBN-2020K-11	20	20	10	125					
●	SVVBN-2525M-11	25	25	12.5	150					
●	SVVBN-1616K-16	16	16	8	125	VSS322	M5	M3.5x11.4x5.7	T15 L:3.5	VB1604
●	SVVBN-2020K-16	20	20	10	125					
●	SVVBN-2525M-16	25	25	12.5	150					

●:庫存 In Stock ○:非標準庫存(請確認交貨期) Non-standard Stock

Zy 外徑車刀 Turning Tools

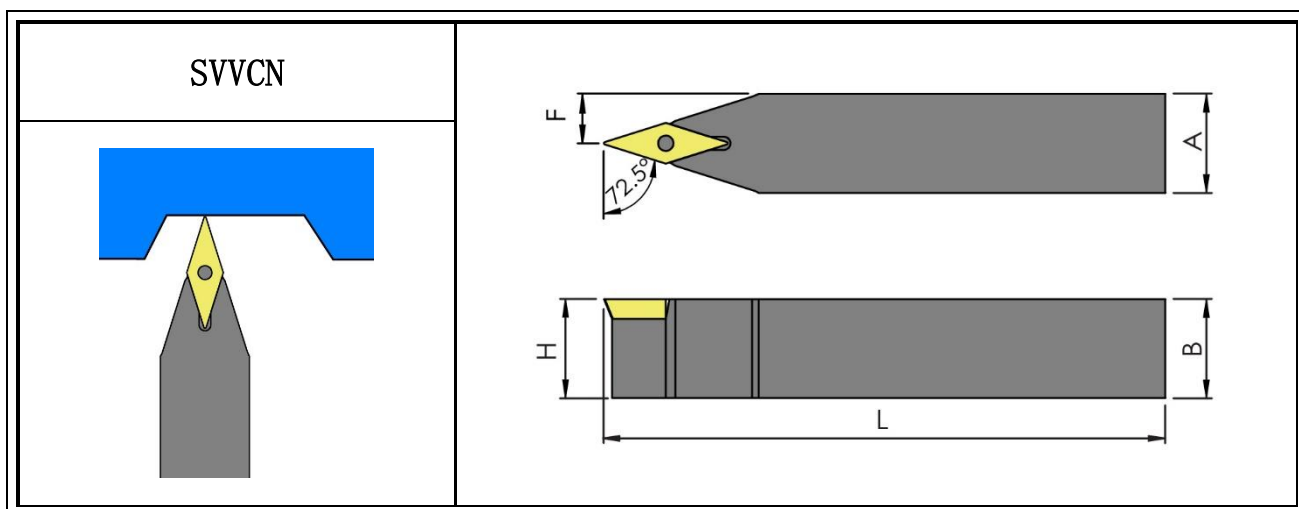



Stock	型號 Model No.	A	B=H	F	L	墊片 Shim	墊片螺絲 Shim Screw	螺絲 Screw	板手 Wrench	刀片 Insert
●	SVVCN-1010H-11	10	10	5	100	-	-	M2.5x6.0x3.6	T8	VC1103
●	SVVCN-1212K-11	12	12	6	125					
●	SVVCN-1616K-11	16	16	8	125					
●	SVVCN-2020K-11	20	20	10	125					
●	SVVCN-2525M-11	25	25	12.5	150					
●	SVVCN-1616K-16	16	16	8	125	VSS322	M5	M3.5x11.4x5.7	T15 L:3.5	VC1604
●	SVVCN-2020K-16	20	20	10	125					
●	SVVCN-2525M-16	25	25	12.5	150					

●:庫存 In Stock ○:非標準庫存(請確認交貨期) Non-standard Stock

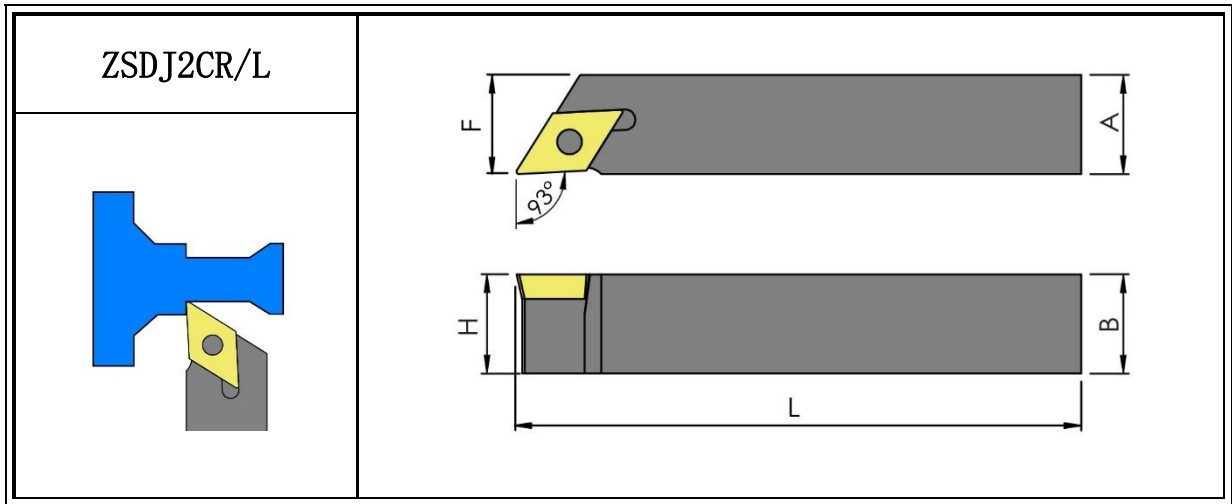
Zy 外徑車刀-走心式 Tool Holder For Automatic Lathes





Stock		型號 Model No.	A	B=H	F	L	 螺絲 Screw	 板手 Wrench	刀片 Insert
R	L								
●	●	ZSDJ2CR-1010H-07	10	10	10	100	M2.5x6.0x3.6	T8	DC0702
●	○	ZSDJ2CR-1010K-07	10	10	10	125			
●	●	ZSDJ2CR-1212K-07	12	12	12	125			
●	●	ZSDJ2CR-1616K-07	16	16	16	125			
●	○	ZSDJ2CR-2020K-07	20	20	20	125			
●	●	ZSDJ2CR-1010H-11	10	10	10	100	M4x8.8x5.4	T15	DC11T3
●	●	ZSDJ2CR-1212K-11	12	12	12	125			
●	○	ZSDJ2CR-1212K-11AL	12	12	12	125			
●	●	ZSDJ2CR-1616K-11	16	16	16	125			
●	○	ZSDJ2CR-1616K-11AL	16	16	16	125			
●	●	ZSDJ2CR-2020K-11	20	20	20	125			

●:庫存 In Stock ○:非標準庫存(請確認交貨期) Non-standard Stock

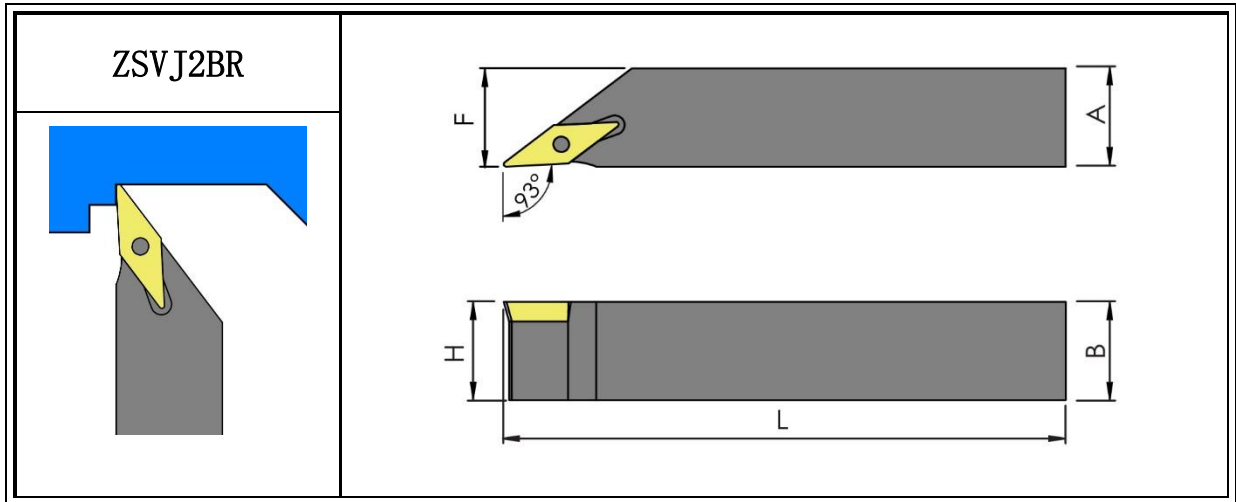
Zy 外徑車刀-走心式 Tool Holder For Automatic Lathes

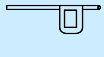

Stock	型號 Model No.	A	B=H	F	L	 墊片 Shim	 墊片螺絲 Shim Screw	 螺絲 Screw	 板手 Wrench	刀片 Insert
●	ZSVJ2BR-1010H-11	10	10	10	100	-	-	M2.5x6.0x3.6	T8	VB1103
●	ZSVJ2BR-1212K-11	12	12	12	125					
●	ZSVJ2BR-1212K-11-A	12	12	12	125					
●	ZSVJ2BR-1616K-11	16	16	16	125					
●	ZSVJ2BR-1616K-16	16	16	16	125	VSS322	M5	M3.5x11.4x5.7	T15	VB16T3
●	ZSVJ2BR-2020K-16	20	20	20	125					

●:庫存 In Stock ○:非標準庫存(請確認交貨期) Non-standard Stock

Zy 外徑車刀-走心式 Tool Holder For Automatic Lathes

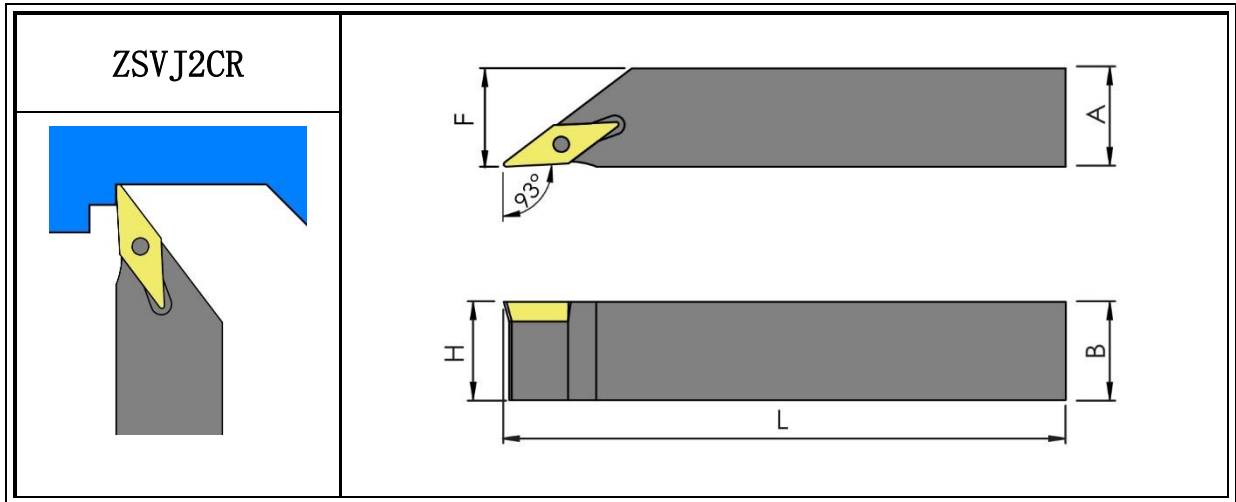

Stock	型號 Model No.	A	B=H	F	L	螺絲 Screw	扳手 Wrench	刀片 Insert
●	ZSVJ2CR-1010H-11	10	10	10	100	M2.5x6.0x3.6	T8	VC1103
●	ZSVJ2CR-1212K-11	12	12	12	125			
●	ZSVJ2CR-1212K-11A	12	12	12	125			
●	ZSVJ2CR-1212K-11-A	12	12	12	125			
●	ZSVJ2CR-1616K-11	16	16	16	125			
●	ZSVJ2BR-1616K-16	16	16	16	125	M3.5x11.4x5.7	T15	VC1604
●	ZSVJ2CR-2020K-16	20	20	20	125	VSS322 菱形刀墊 +M5	L3.5	
●	ZSVJ2CR-2020K-16B	20	20	20	125	M3.5x12.0x5.4	T15	

●:庫存 In Stock ○:非標準庫存(請確認交貨期) Non-standard Stock

*ZSVJ2CR-2020K-16B 沒有刀墊