

內徑車刀系列刀桿

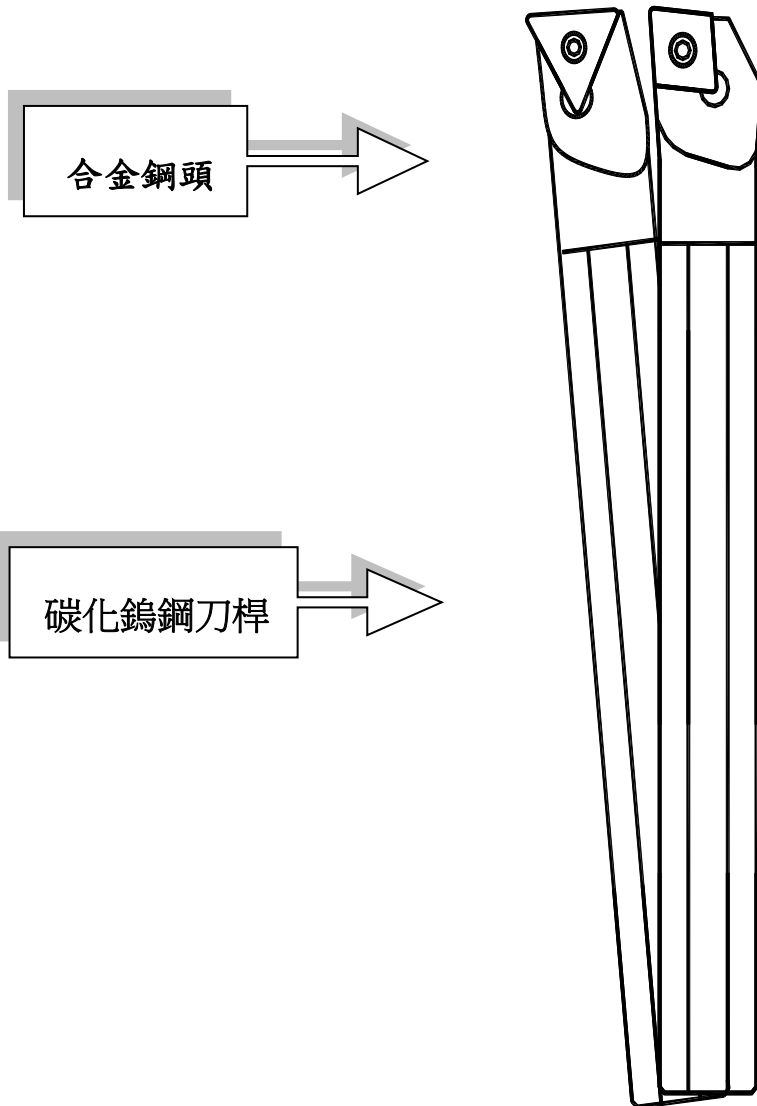

內圓車刀表示方法 Boring Bar Identification system

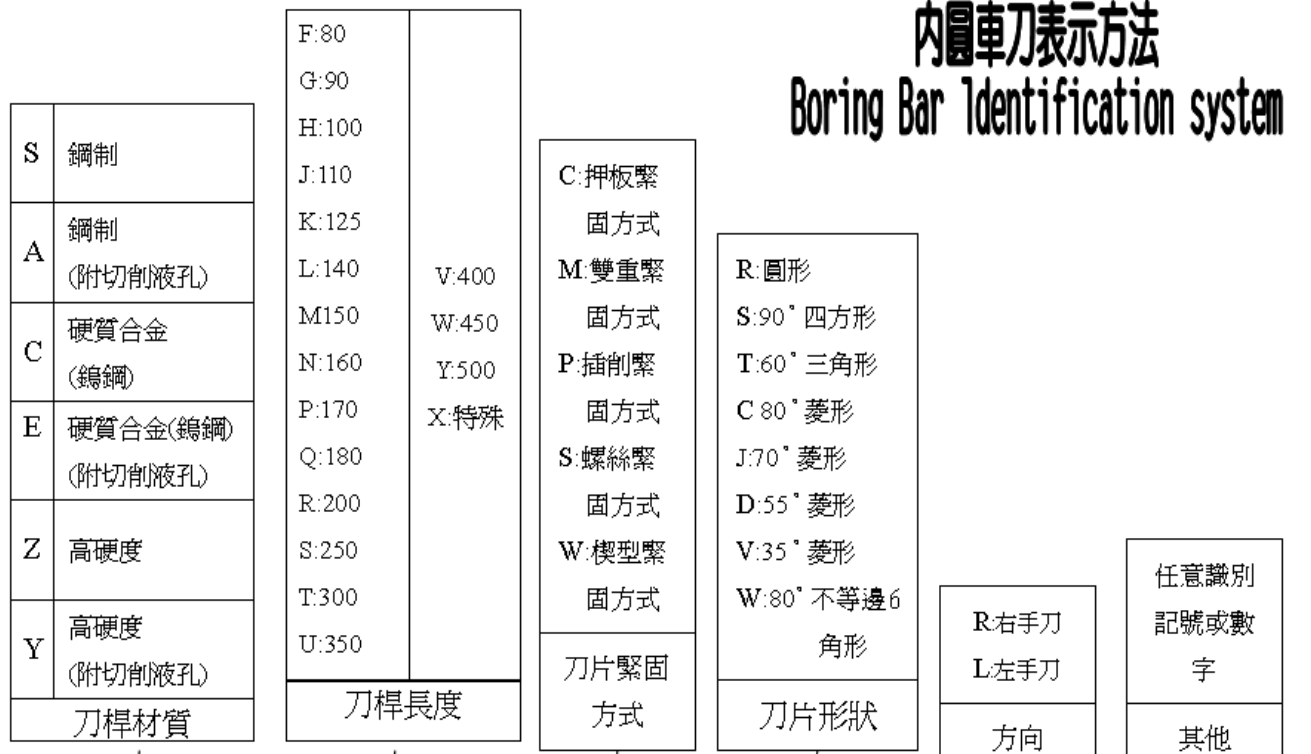

S **12** **M** - **S** **T** **L** **C** **R** **09** - **16**

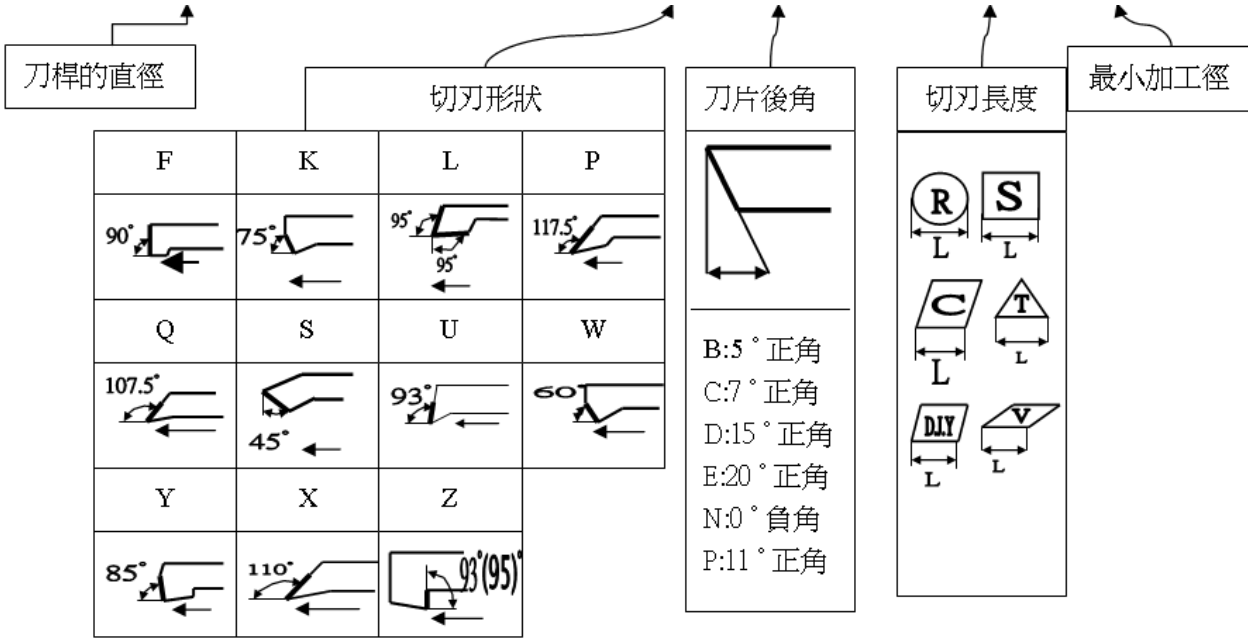

Zy 微小徑內徑車刀 Mini Boring Bars

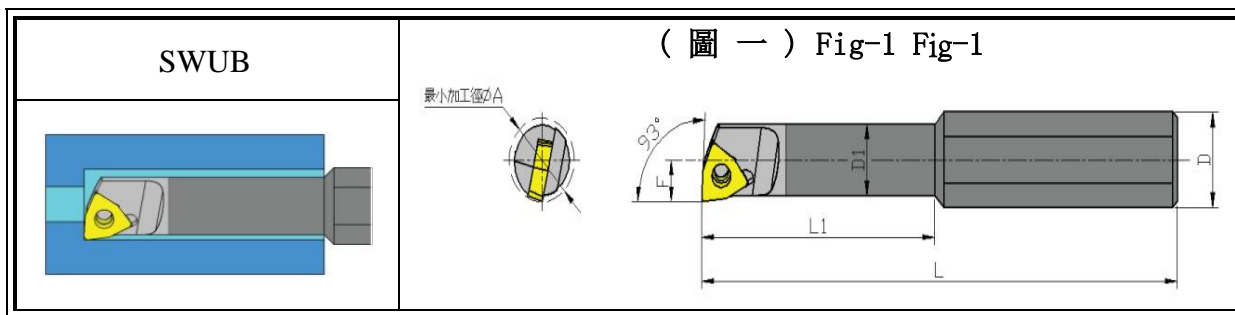

stock	型號 Model No.	最小加工徑 A	F	D1	D	L1	L	螺絲 Screw	扳手 Wrench	刀片 Insert
鎢鋼柄 (圖一) Carbide Shank (Fig-1)										
○	C0805K-SWUCR02-06-10L	6	3	5	8	10	125	M2x3.7x2.6-60	T6	WC0201
●	C0806K-SWUBR06-07-20L	7	3.5	6	8	20	125	M2x5.0x2.6	T6	WB0601
●	C0807K-SWUBR06-08-20L	8	4	7	8	20	125			
●	C0807K-SWUBR06-08-30L	8	4	7	8	20	125			
○	C1005M-SWUBR06-06-15L	6	3	5	10	15	150	M2x3.7x2.6-60		
○	C1006M-SWUBR06-07-15L	7	3.5	6	10	15	150	M2x5.0x2.6		
○	C1007M-SWUBR06-08-20L	8	4	7	10	20	150			
○	C1205M-SWUBR06-06-15L	6	3	5	12	15	150	M2x3.7x3.6-60		
○	C1605M-SWUBR06-06-15L	6	3	5	16	15	150			
合金鋼 (圖一) Alloy Steel (Fig-1)										
●	S0805K-SWUCR02-06-10L	6	3	5	8	10	125	M2x3.7x2.6-60	T6	WC0201
●	S1005K-SWUBR06-06-15L	6	2.8	5	10	15	125	M2x5.0x2.6		WC0601
●	S1006K-SWUBR06-07-18L	7	3.5	6	10	18	125			
●	S1007K-SWUBR06-08-20L	8	4	7	10	20	125			
●	S1205K-SWUBR06-06-15L	6	3	5	12	15	125	M2x3.7x2.6-60		

●:庫存 In Stock ○:非標準庫存(請確認交貨期) Non-standard Stock

Zy 微小徑內徑車刀 Mini Boring Bars

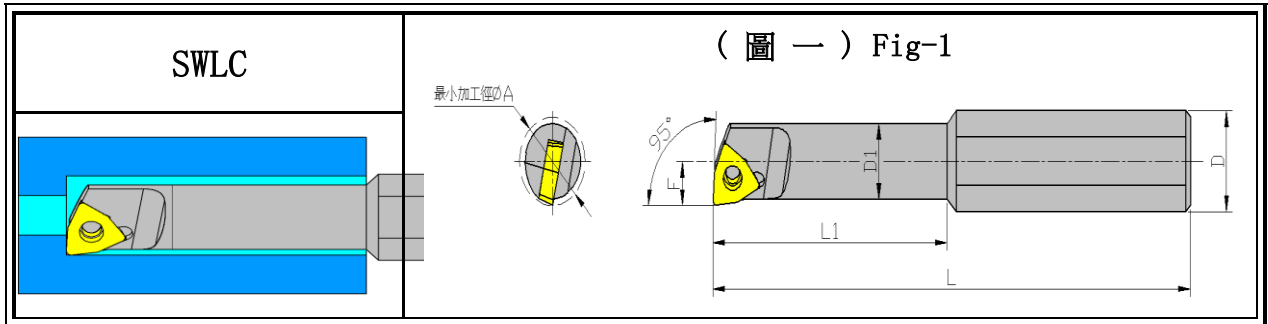

Stock	型號 Model No.	最小加工徑 A	F	D1	D	L1	L	螺絲 Screw	扳手 Wrench	刀片 Insert
合金鋼柄 (圖一) Alloy Steel (Fig-1)										
●	S0805K-SWLCR02-06-10L	6	3	5	8	10	125	M2x3.7x2.6-60	T6	WC0201
○	S0806K-SWLCR02-07-10L	7	3.5	6	8	10	125	M2x5.0x2.6		
●	S1005K-SWLCR02-06-15L	6	3	05	10	15	125			

●:庫存 In Stock ○:非標準庫存(請確認交貨期) Non-standard Stock

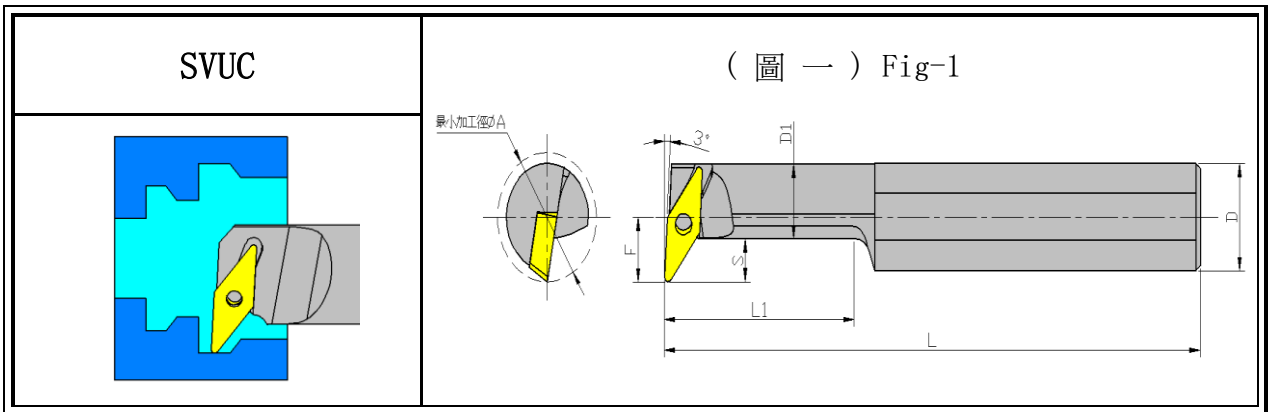

Stock	型號 Model No.	最小加工徑 A	F	D1	D	L1	L	S	螺絲 Screw	扳手 Wrench	刀片 Insert
合金鋼柄 (圖一) Alloy Steel (Fig-1)											
●	S1008K-SVUCR07-12-20L	12	6	8	10	20	125	3	M2x5.0x2.6	T6	VC0702
●	S1210M-SVUCR07-14-30L	14	7	10	12	30	150	3			

●:庫存 In Stock ○:非標準庫存(請確認交貨期) Non-standard Stock

Zy 微小徑內徑車刀 Mini Boring Bars

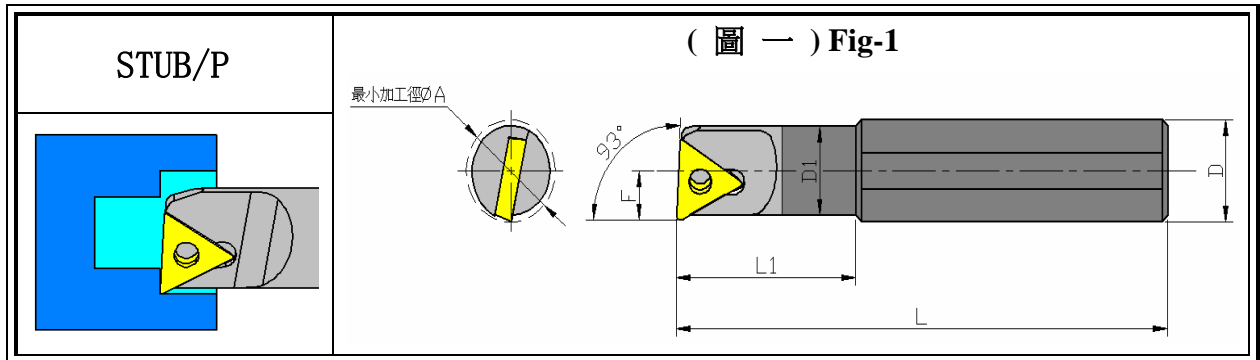

stock	型號 Model No.	最小加工徑 A	F	D1	D	L1	L	螺絲 Screw	板手 Wrench	刀片 Insert
錫鋼柄 (圖一) Carbide Shank (Fig-1)										
●	C0806K-STUBR06-07-20L	7	3.5	6	8	20	125	M2x5.0x2.6	T6	TB0601
●	C0807K-STUBR06-08-20L	8	4	7	8	20	125			
●	C1006M-STUBR06-07-20L	7	3.5	6	10	20	150			
○	C1206M-STUBR06-07-20L	7	3.5	6	12	20	150			
○	C1207M-STUBR06-08-20L	8	4	7	12	20	150			
合金鋼柄 (圖一) Alloy Steel (Fig-1)										
●	S0806K-STUBR06-07-20L	7	3.5	6	8	20	125	M2x5.0x2.6	T6	TB0601
●	S0807K-STUBR06-08-20L	8	4	7	8	20	125			
●	S1006K-STUBR06-07-20L	7	3.5	6	10	20	125			
●	S1206K-STUBR06-07-15L	7	3.5	6	12	15	125			
●	S1207K-STUBR06-08-20L	8	4	7	12	20	125			

●:庫存 In Stock ○:非標準庫存(請確認交貨期) Non-standard Stock

stock	型號 Model No.	最小加工徑 A	F	D1	D	L1	L	螺絲 Screw	板手 Wrench	刀片 Insert
合金鋼柄 (圖一) Alloy Steel (Fig-1)										
●	S1608K-STUPR08-10-20L	10	5.5	8	16	20	125	M2.2x5.1x3.1	T7	TP0802
●	S1608K-STUPR09-10-20L	10	5.5	8	16	20	125	M2.5x6.0x3.6	T8	TP0902
●	S1610K-STUPR11-12-20L	12	6.5	10	16	20	125	M3x7.8x4.1	T9	TP1102

Zy 微小徑內徑車刀 Mini Boring Bars

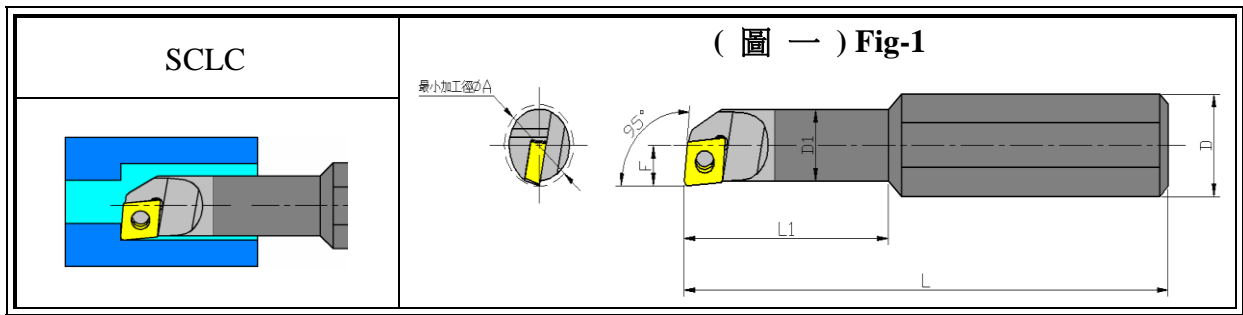

Stock	型號 Model No.	最小加工徑 A	F	D	D1	L1	L	螺絲 Screw	扳手 Wrench	刀片 Insert
鎢鋼柄 (圖一) Carbide Shank (Fig-1)										
●	C0604J-SCLCR03-05-20L	5	2.8	6	4	20	110	M1.8x4.0x2.5-54	T6	CC0301
●	C0605J-SCLCR03-06-10L	6	3	6	5	10	110			
●	C0804K-SCLCR03-05-10L	5	2.8	8	4	10	125			
●	C0805K-SCLCR03-06-10L	6	3	8	5	10	125			
○	C1004M-SCLCR03-05-10L	5	2.5	10	4	10	150			
○	C1204M-SCLCR03-05-10L	5	2.5	12	4	10	150	M2.2x5.1x3.1	T7	CC0401
●	C0807K-SCLCR04-08-20L	8	4	8	7	20	125			
○	C1206M-SCLCR04-07-15L	7	3.5	12	6	15	150	M2.5x6.0x3.6	T8	CC0602
●	C0807K-SCLCR06-08-20L	8	4	8	7	20	125			
○	C1208M-SCLCR06-10-20L	10	5	12	8	20	150			
○	C1607M-SCLCR06-08-20L	8	4	16	7	20	150			
○	C1609M-SCLCR06-10-25L	10	5	16	9	25	150	M4x8.8x5.4	T15	CC09T3
○	C1614R-SCLCR09-16-30L	16	8	16	14	30	200			
合金鋼柄 (圖一) Alloy Steel (Fig-1)										
●	S1004K-SCLCR03-05-10L	5	2.5	10	4	10	125	M1.8x4.0x2.5-54	T6	CC0301
●	S1204K-SCLCR03-05-10L	5	2.5	12	4	10	125			
●	S1205K-SCLCR04-06-15L	6	3	12	5	15	125	M2.2x5.1x3.1	T7	CC0401
●	S1206K-SCLCR04-07-15L	7	3.5	12	6	15	125			
●	C0807K-SCLCR06-08-20L	8	4	8	7	20	125	M2.5x6.0x3.6	T8	CC0602
●	S1208K-SCLCR06-10-20L	10	5	12	8	20	125			
●	S1607K-SCLCR06-08-20L	8	4	16	7	20	125			
●	S1609K-SCLCR06-10-25L	10	5	16	9	25	125			
●	S1614Q-SCLCR09-16-30L	16	8	16	14	30	180	M4x8.8x5.4	T15	CC09T3

Zy 內徑車刀 Boring Bars

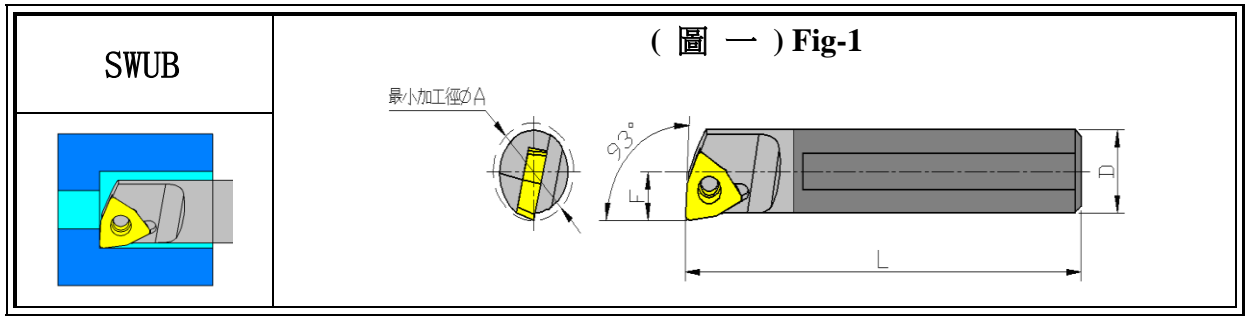



Stock	型號 Model No.	最小加工徑 A	F	D	L	螺絲 Screw	扳手 Wrench	刀片 Insert
鎢鋼柄 (圖一) Carbide Shank (Fig-1)								
●	C04G-SWUBR/L06-055	5.5	2.75	4	90	M2x3.7x2.6-60	T6	WB0601
●	C05H-SWUBR/L06-06	6	3	5	100			
●	C06J-SWUBR/L06-07	7	3.5	6	110	M2x5.0x2.6	T6	WB0601
●	C07J-SWUBR/L06-08	8	4	7	110			
●	C08K-SWUBR/L06-09	9	4.5	8	125			
●	C07J-SWUBR/L06-08	8	4	7	110	M2x5.0x2.6	T6	WB0802
●	C08K-SWUBR/L08-10	10	5	8	125			
●	C10M-SWUBR/L08-12	12	6	10	150			

●:庫存 In Stock ○:非標準庫存(請確認交貨期) Non-standard Stock

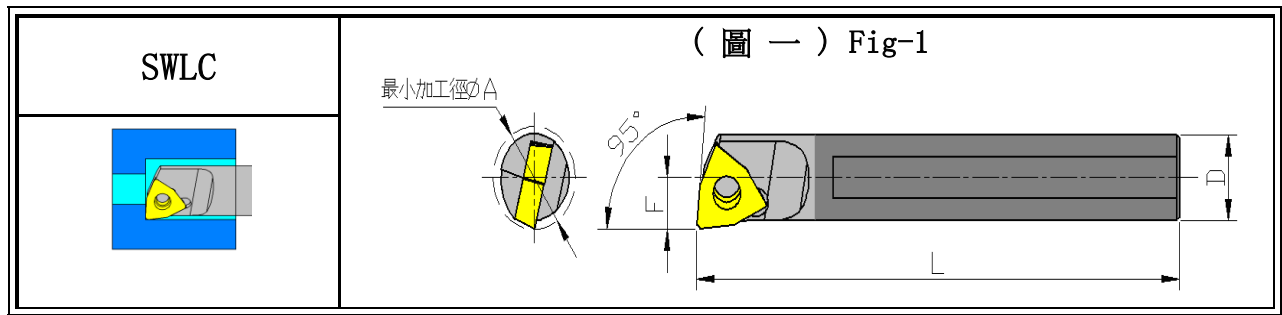
Zy 內徑車刀 Boring Bars



Stock	型號 Model No.	最小加工徑 A	F	D	L	 螺絲 Screw	 板手 Wrench	刀片 Insert
鎢鋼柄 (圖一) Carbide Shank (Fig-1)								
●	C05H-SWLCR/L02-06	6	3	5	100	M2x5.0x2.6	T6	WC0201
●	C06J-SWLCR/L02-07	7	3.5	6	110			
●	C07J-SWLCR/L02-08	8	4	7	110			

●:庫存 In Stock ○:非標準庫存(請確認交貨期) Non-standard Stock

Zy 內徑車刀 Boring Bars

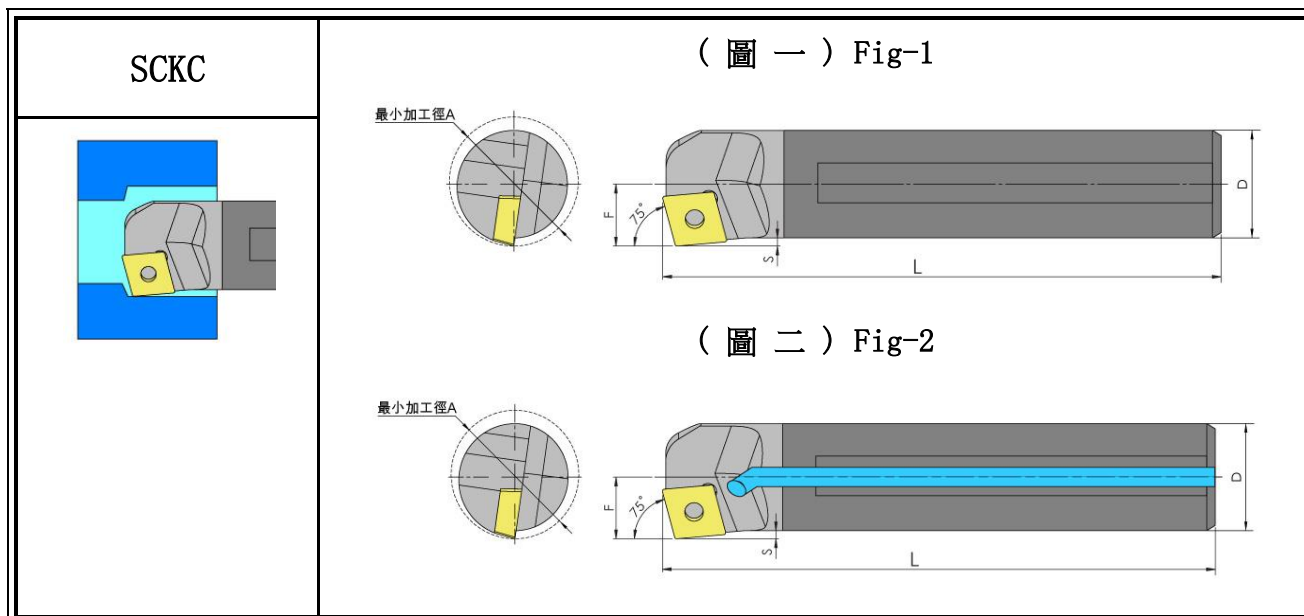

Stock	型號 Model No.	最小加工徑 A	F	D	L	螺絲 Screw	板手 Wrench	刀片 Insert
鎢鋼柄 (圖一) Carbide Shank (Fig-1)								
●	C08K-SCKCR/L06-10	10	5.5	8	125	M2.5x6.0x3.6	T8	CC0602
●	C10M-SCKCR/L06-12	12	6	10	150			
●	C12M-SCKCR/L06-16	16	8	12	150			
●	C12M-SCKCR/L09-16	16	8	12	150	M4x8.8x5.4	T15	CC09T3
●	C14M-SCKCR/L09-17	17	8.5	14	150			
●	C16M-SCKCR/L09-20	20	9.5	16	150			
鎢鋼柄 + 水孔 (圖二) Carbide Shank With Coolant (Fig-2)								
○	E10M-SCKCR/L06-13	13	6	10	150	M2.5x6.0x3.6	T8	CC0602
○	E16M-SCKCR/L09-20	20	9.5	20	150	M4x8.8x5.4	T15	CC09T3
○	E20R-SCKCR/L09-24	24	11.5	20	200			
合金鋼 (圖一) Alloy Steel (Fig-1)								
●	S08K-SCKCR/L06-10	10	5.5	8	125	M2.5x6.0x3.6	T8	CC0602
●	S10K-SCKCR/L06-13	13	6	10	125			
●	S12M-SCKCR/L06-16	16	8	12	150			
●	S12M-SCKCR/L09-16	16	8	12	150	M4x8.8x5.4	T15	CC09T3
●	S16Q-SCKCR/L09-20	20	8.5	16	180			
●	S20R-SCKCR/L09-24	24	11.5	20	200			

Zy 內徑車刀 Boring Bars

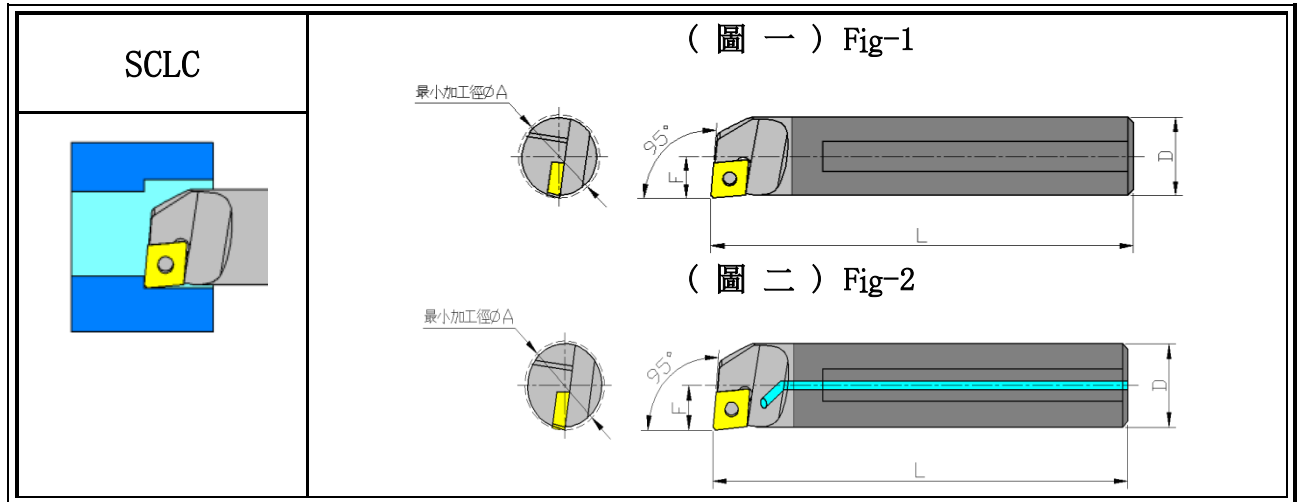

Stock	型號 Model No.	最小加工徑 A	F	D	L	螺絲 Screw	板手 Wrench	刀片 Insert			
鎢鋼柄 (圖一) Carbide Shank (Fig-1)											
●	C04G-SCLCR/L03-045	4.5	2.5	4	90	M1.8x4.0x2.5	T6	CC0301			
●	C04G-SCLCR/L03-05	5	2.8	4	90						
●	C05H-SCLCR/L03-06	6	3	5	100						
●	C05H-SCLCR/L04-06	6	3	5	100	M2.2x5.1x3.1	T7	CC0401			
●	C06J-SCLCR/L04-07	7	3.5	6	110						
●	C07J-SCLCR/L04-08	8	4	7	110						
●	C07J-SCLCR/L06-08	8	4	7	110	M2.5x6.0x3.6	T8	CC0602			
●	C08K-SCLCR/L06-09	9	4.5	8	125						
●	C08K-SCLCR/L06-10	10	5	8	125						
●	C10M-SCLCR/L06-12	12	6	10	150						
●	C12M-SCLCR/L06-14	14	7	12	150						
●	C12Q-SCLCR/L06-14	14	7	12	180						
●	C14M-SCLCR/L06-16	16	8	14	150						
●	C16R-SCLCR/L06-18	18	9	16	200						
●	C12M-SCLCR/L09-14	14	7	12	150				M4x8.8x5.4	T15	CC09T3
●	C12Q-SCLCR/L09-14	14	7	12	180						
●	C14M-SCLCR/L09-16	16	8	14	150						
●	C16M-SCLCR/L09-18	18	9	16	150						
●	C16R-SCLCR/L09-18	18	9	16	200						
●	C20R-SCLCR/L09-22	22	11	20	200						
●	C20S-SCLCR/L09-22	22	11	20	250						
○	C25S-SCLCR/L09-28	28	14.5	25	250						

鎢鋼柄 + 水孔 (圖二) Carbide Shank With Coolant (Fig-2)								
●	E05H-SCLCR/L03-06	6	3	05	100	M1. 8x4. 0x2. -54	T6	CC0301
●	E05H-SCLCR/L04-06	6	3	05	100	M2. 2x5. 1x3. 1	T7	CC0401
●	E06J-SCLCR/L04-07	7	3.5	6	110			
●	E08K-SCLCR/L06-10	10	5	8	125	M2. 5x6. 0x3. 6	T8	CC0602
●	E10M-SCLCR/L06-12	12	6	10	150			
●	E12M-SCLCR/L06-14	14	7	12	150			
●	E12Q-SCLCR/L06-14	14	7	12	180			
●	E14M-SCLCR/L06-16	16	7.5	14	150			
●	E14Q-SCLCR/L06-16	16	7.5	14	180			
○	E16R-SCLCR/L06-18	18	9	16	200			
●	E12M-SCLCR/L09-14	14	7	12	150	M4x8. 8x5. 4	T15	CC09T3
●	E12Q-SCLCR/L09-14	14	7	12	180			
●	E14M-SCLCR/L09-16	16	7.5	14	150			
●	E14Q-SCLCR/L09-16	16	7.5	14	180			
●	E16R-SCLCR/L09-18	18	9	16	200			
●	E20R-SCLCR/L09-22	22	11	20	200			
●	E20S-SCLCR/L09-22	22	11	20	250			
合金鋼柄 (圖一) Alloy Steel (Fig-1)								
●	S08K-SCLCR/L06-10	10	5	8	125	M2. 5x6. 0x3. 6	T8	CC0602
●	S10K-SCLCR/L06-12	12	6	10	125			
●	S12M-SCLCR/L06-14	14	7	12	150			
●	S16Q-SCLCR/L06-18	18	9	16	180			
●	S12M-SCLCR/L09-14	14	7	12	150	M4x8. 8x5. 4	T15	CC09T3
●	S14N-SCLCR/L09-16	16	9	14	160			
●	S16Q-SCLCR/L09-18	18	9	16	180			
●	S20R-SCLCR/L09-22	22	11	20	200			
高硬度柄 (Y:圖二、Z:圖一) High Hardness Steel With Coolant (Y:Fig-1、Z:Fig-2)								
●	Y10K-SCLCR/L06-12	12	6	10	125	M2. 5x6. 0x3. 6	T8	CC0602
●	Y12M-SCLCR/L06-14	14	7	12	150			
●	Z12M-SCLCR/L06-14	14	7	12	150			
●	Y12M-SCLCR/L09-14	14	7	12	150	M4x10. 6x5. 6	T15	CC09T3
●	Z12M-SCLCR/L09-14	14	7	12	150			
○	Y14N-SCLCR/L09-16	16	8	14	160			
●	Y16N-SCLCR/L09-18	18	9	16	160			
●	Y20R-SCLCR/L09-22	22	11	20	200			
●	Z20R-SCLCR/L09-22	22	11	20	200			
●	Y25R-SCLCR/L09-28	28	14.5	25	200			
●	Y32R-SCLCR/L09-38	38	17.5	32	200			

Zy 內徑車刀 Boring Bars

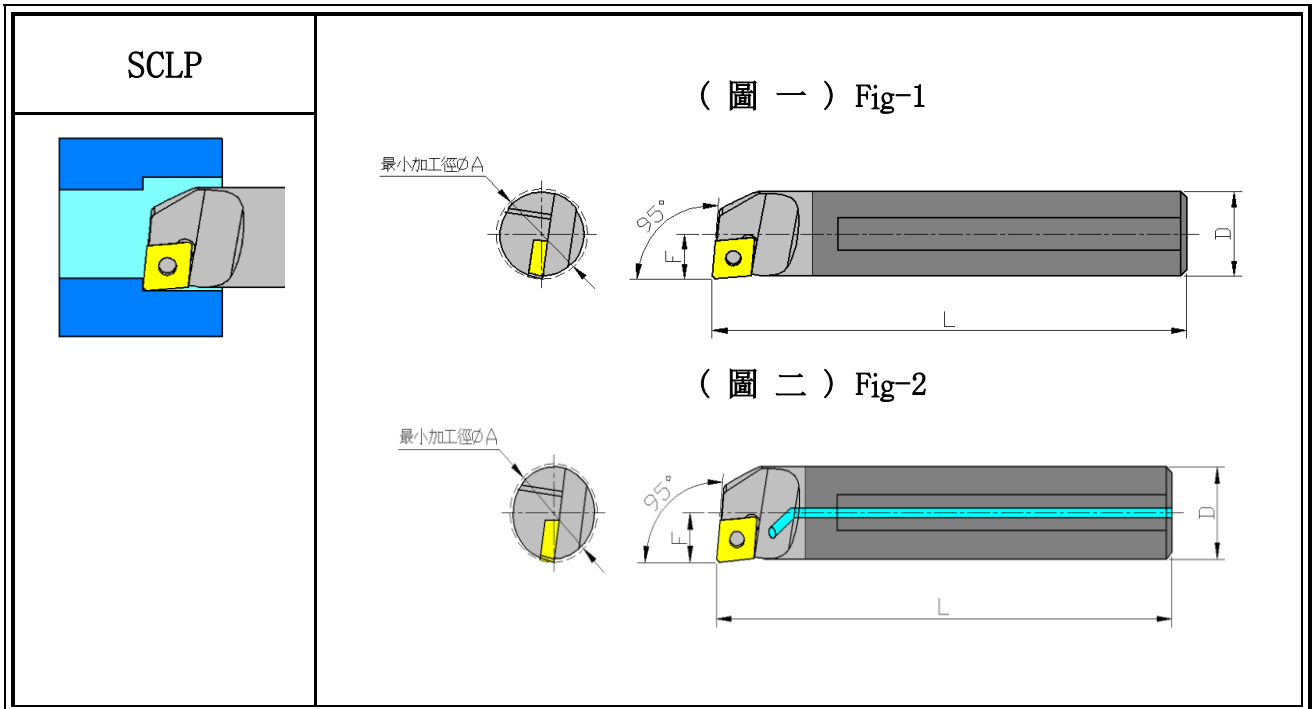

Stock	型號 Model No.	最小加工徑 A	F	D	L	螺絲 Screw	扳手 Wrench	刀片 Insert
鎢鋼柄 (圖一) Carbide Shank (Fig-1)								
○	C08K-SCLPR/L06-10	10	5	8	125	M2.5x6.0x3.6	T8	CP0602
○	C10M-SCLPR/L06-12	12	6	10	150			
○	C12M-SCLPR/L06-15	15	8	12	150			
●	C10M-SCLPR/L08-12	12	6	10	150	M3x7.8x4.1	T9	CP0802
●	C12M-SCLPR/L08-14	14	7	12	150			
○	C12Q-SCLPR/L08-14	14	7	12	180			
●	C12M-SCLPR/L09-14	14	7	12	150	M4x8.8x5.4	T15	CP0903
●	C12Q-SCLPR/L09-14	14	7	12	180			
●	C16R-SCLPR/L09-18	18	9	16	200			
●	C20R-SCLPR/L09-22	22	11	20	200			
●	C20S-SCLPR/L09-22	22	11	20	250			
○	C25R-SCLPR/L09-28	30	14	25	200			
鎢鋼柄 + 水孔 (圖二) Carbide Shank With Coolant (Fig-2)								
●	E16R-SCLPR/L09-18	18	9	16	200	M4x8.0x5.4	T15	CP0903
●	E20R-SCLPR/L09-22	22	11	20	200			
●	E20S-SCLPR/L09-22	22	11	20	250			

○	E25R-SCLPR/L09-28	28	14	25	200			
○	E32S-SCLPR/L09-38	38	17.5	32	250			
合金鋼柄 (圖一) Alloy Steel (Fig-1)								
●	S10K-SCLPR/L08-12	12	6	10	125	M3x7.8x4.1	T9	CP0802
●	S12M-SCLPR/L08-14	14	7	12	150			
●	S12M-SCLPR/L09-14	14	7	12	150	M4x8.8x5.4	T15	CP0903
●	S16Q-SCLPR/L09-18	18	9	16	180			
○	S20R-SCLPR/L09-22	22	11	20	200			
高硬度柄 (Y:圖二、Z:圖一) High Hardness Steel With Coolant (Y:Fig-1、Z:Fig-2)								
●	Y16Q-SCLPR/L09-18	18	9	16	160	M4x8.8x5.4	T15	CP09T3
○	Z16Q-SCLPR/L09-18	18	9	16	160			
○	Y20R-SCLPR/L09-22	22	11	20	200			
●	Z20R-SCLPR/L09-22	22	11	20	200			

●:庫存 In Stock ○:非標準庫存(請確認交貨期) Non-standard Stock

Zy 內徑車刀 Boring Bars

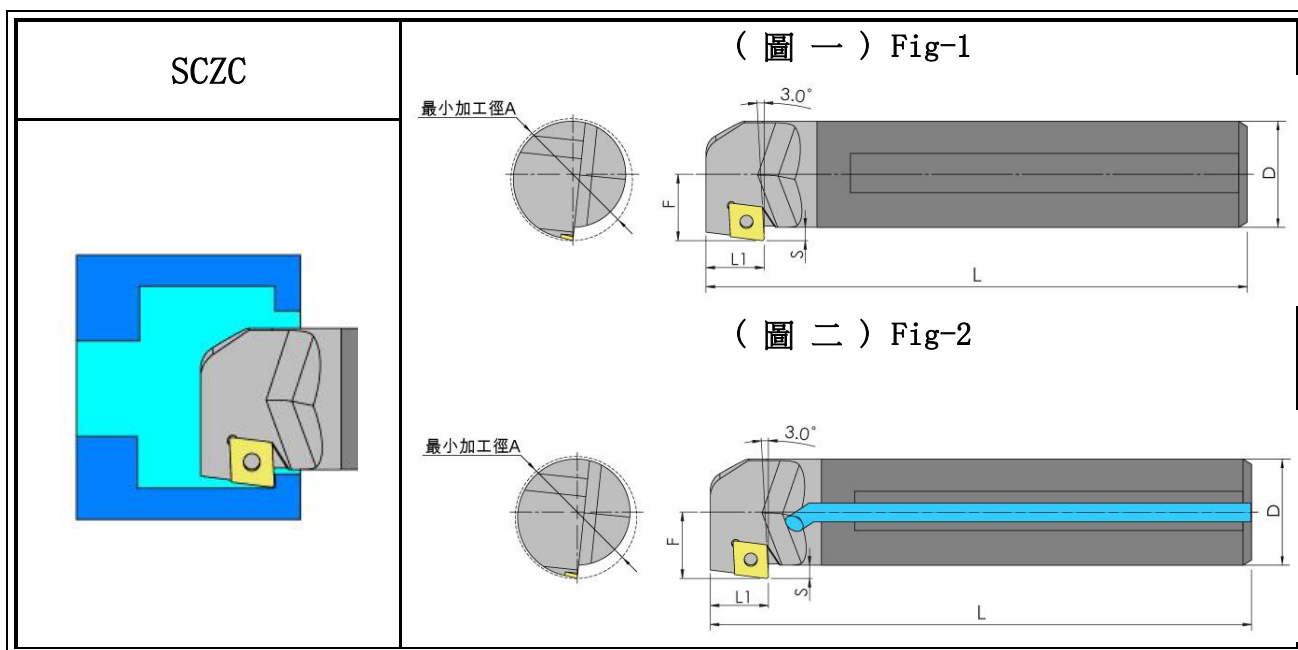

Stock	型號 Model No.	最小加工徑 A	F	D	S	L1	L	螺絲 Screw	板手 Wrench	刀片 Insert
鎢鋼柄 (圖一) Carbide Shank (Fig-1)										
●	C08K-SCZCR/L06-12	12	6.5	8	2.5	11	125	M2.5x6.0x3.6	T8	CC0602
●	C10M-SCZCR/L06-14	14	7.5	10	2.5	12	150			
●	C12M-SCZCR/L06-16	16	8.5	12	2.5	12	150			
●	C16R-SCZCR/L06-20	20	10.5	16	2.5	12	200			
○	C16R-SCZCR/L09-21	21	11.5	16	3.5	18	200	M4x8.8x5.4	T15	CC09T3
合金鋼柄 (圖一) Alloy Steel (Fig-1)										
●	S08K-SCZCR/L06-12	12	6.5	8	2.5	11	125	M2.5x6.0x3.6	T8	CC0602
●	S10K-SCZCR/L06-14	14	7.5	10	2.5	12	150			
●	S12M-SCZCR/L06-16	16	8.5	12	2.5	12	150			
鎢鋼柄 + 水孔 (圖二) Carbide Shank With Coolant (Fig-2)										
●	C08K-SCZCR/L06-12	12	6.5	8	2.5	11	125	M2.5x6.0x3.6	T8	CC0602
●	C10M-SCZCR/L06-14	14	7.5	10	2.5	12	150			
●	C12M-SCZCR/L06-16	16	8.5	12	2.5	12	150			
●	C16R-SCZCR/L06-20	20	10.5	16	2.5	12	200			

●:庫存 In Stock ○:非標準庫存(請確認交貨期) Non-standard Stock

Zy 內徑車刀 Boring Bars

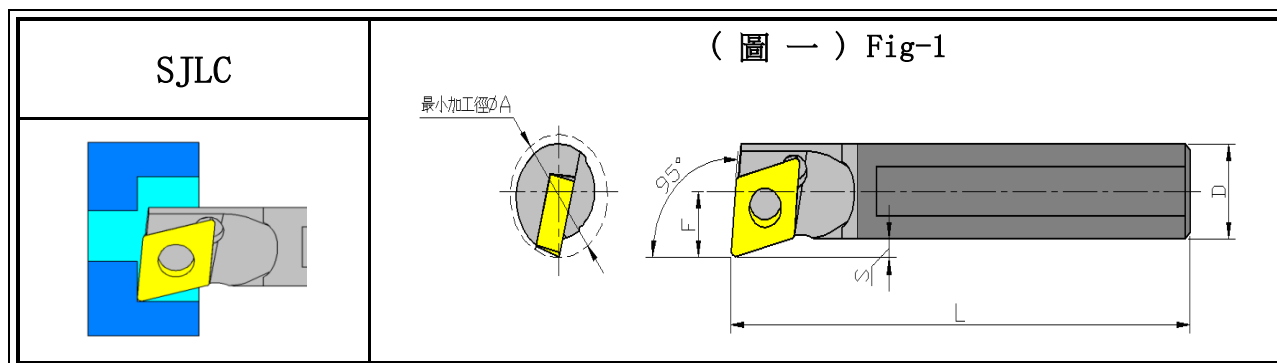

Stock	型號 Model No.	最小加工徑 A	F	D	S	L	螺絲 Screw	扳手 Wrench	刀片 Insert
鎢鋼柄 (圖一) Carbide Shank (Fig-1)									
●	C04G-SJLCR/L03-055	5.5	2.95	4	0.65	90	M1.8x4.0x2.5-54	T6	JC0301

●:庫存 In Stock ○:非標準庫存(請確認交貨期) Non-standard Stock

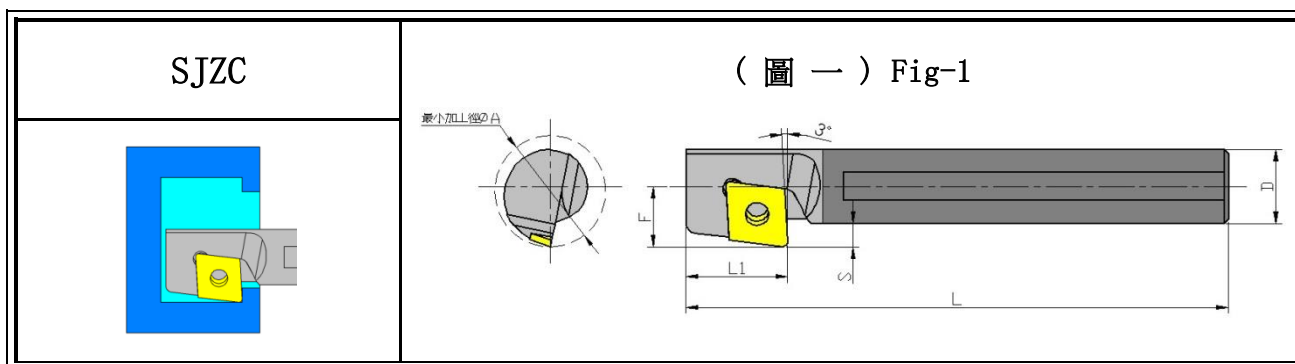

Stock	型號 Model No.	最小加工徑 A	F	D	S	L1	L	螺絲 Screw	扳手 Wrench	刀片 Insert
鎢鋼柄 (圖一) Carbide Shank (Fig-1)										
●	C04G-SJZCR/L03-065	6.5	4	4	1.8	4.8	90	M1.8x4.0x2.5-54	T6	JC0301

●:庫存 In Stock ○:非標準庫存(請確認交貨期) Non-standard Stock

Zy 內徑車刀 Boring Bars

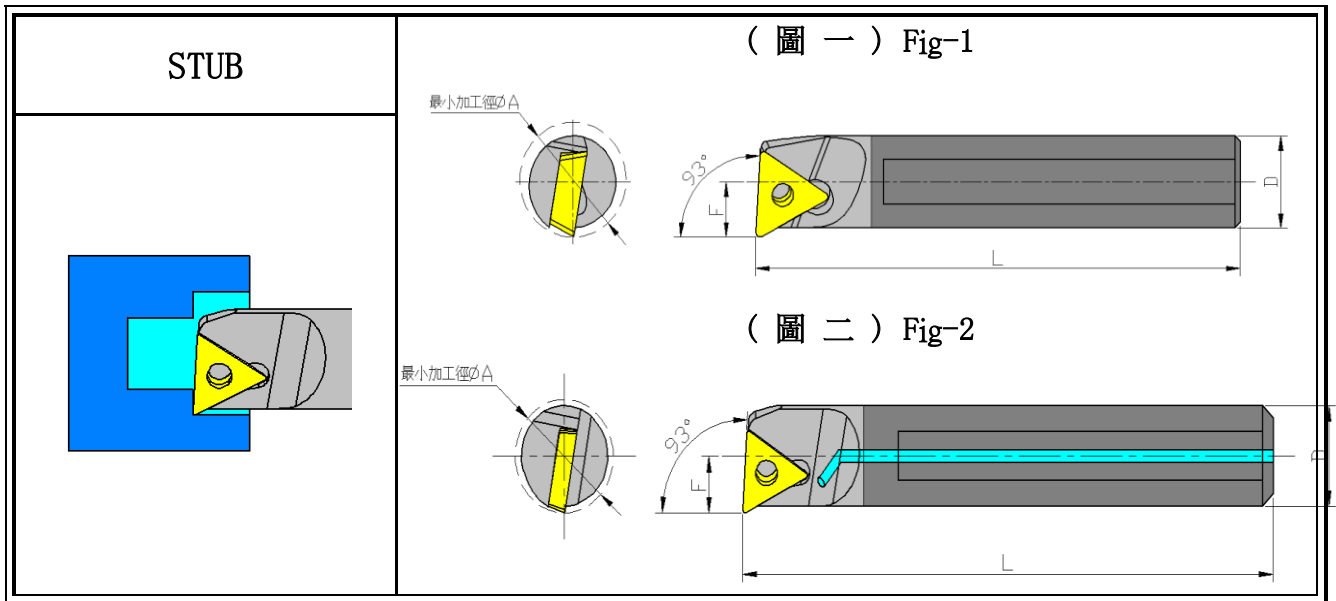



Stock	型號 Model No.	最小加工徑 A	F	D	L	螺絲 Screw	板手 Wrench	刀片 Insert
鎢鋼柄 (圖一) Carbide Shank (Fig-1)								
●	C06J-STUBR/L06-07	7	3.5	6	110	M2x5.0x2.6	T6	TB0601
●	C07J-STUBR/L06-08	8	4	7	110			
●	C08K-STUBR/L06-09	9	4.5	8	125			
●	C10M-STUBR/L06-12	12	5.5	10	150			
鎢鋼柄 + 水孔 (圖二) Carbide Shank With Coolant (Fig-2)								
●	E06J-STUBR/L06-07	7	3.5	6	110	M2x5.0x2.6x60	T6	TB0601
●	E08K-STUBR/L06-09	9	4.5	8	125			
合金鋼柄 (圖一) Alloy Steel (Fig-1)								
●	S08K-STUBR/L06-09	9	4.5	8	125	M2x5.0x2.6x60	T6	TB0601
高硬度柄 (Y:圖二、Z:圖一) High Hardness Steel With Coolant (Y:Fig-1、Z:Fig-2)								
●	Z08H-STUBR/L06-09	9	4.5	8	125	M2x5.0x2.6x60	T6	TB0601

●:庫存 In Stock ○:非標準庫存(請確認交貨期) Non-standard Stock

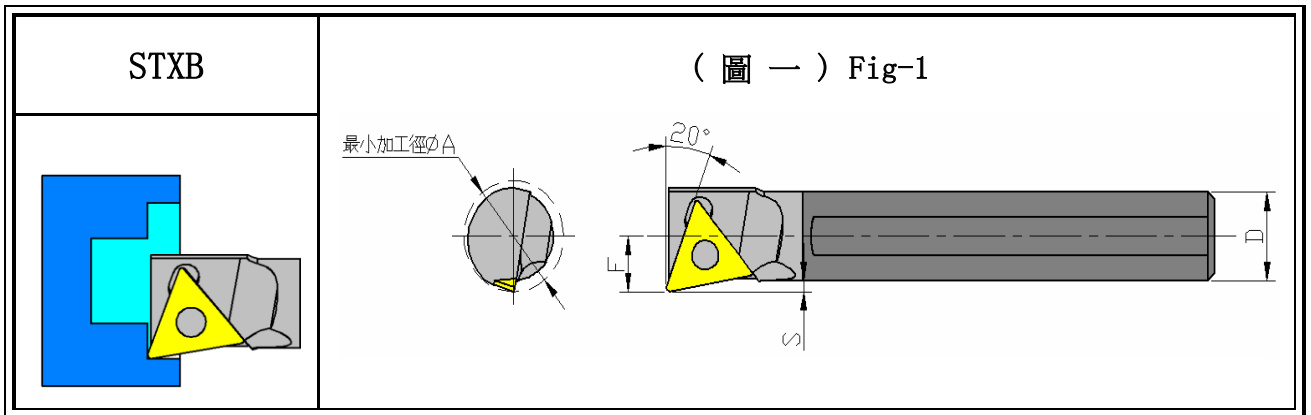

Zy 內徑車刀 Boring Bars

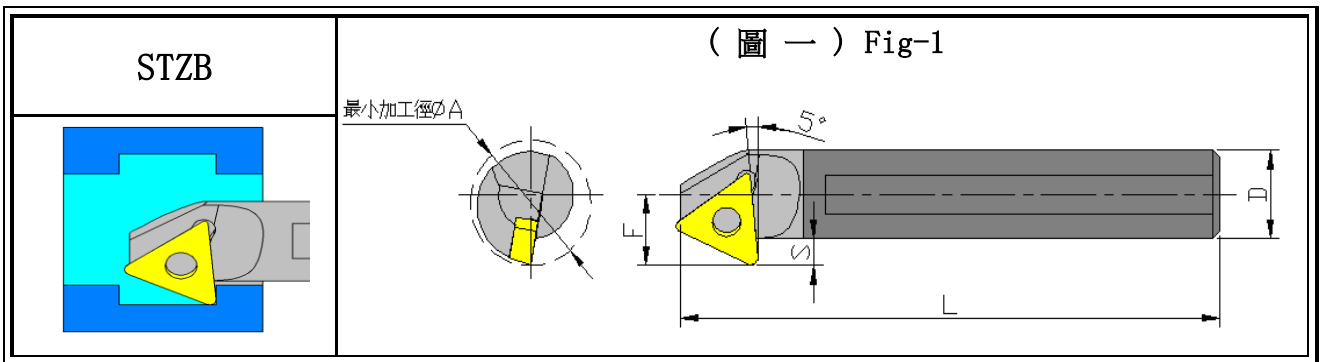

Stock	型號 Model No.	最小加工徑 A	F	D	S	L	 螺絲 Screw	 板手 Wrench	刀片 Insert
鎢鋼柄 (圖一) Carbide Shank (Fig-1)									
○	C06J-STXBR/L06-075	7.5	3.75	6	0.5	110	M2x5.0x2.6	T6	TB0601

●:庫存 In Stock ○:非標準庫存(請確認交貨期) Non-standard Stock



Stock	型號 Model No.	最小加工徑 A	F	D	S	L	 螺絲 Screw	 板手 Wrench	刀片 Insert
鎢鋼柄 (圖一) Carbide Shank (Fig-1)									
●	C06J-STZBR/L06-085	8.5	5	6	2	110	M2x5.0x2.6	T6	TB0601

●:庫存 In Stock ○:非標準庫存(請確認交貨期) Non-standard Stock

Zy 內徑車刀 Boring Bars

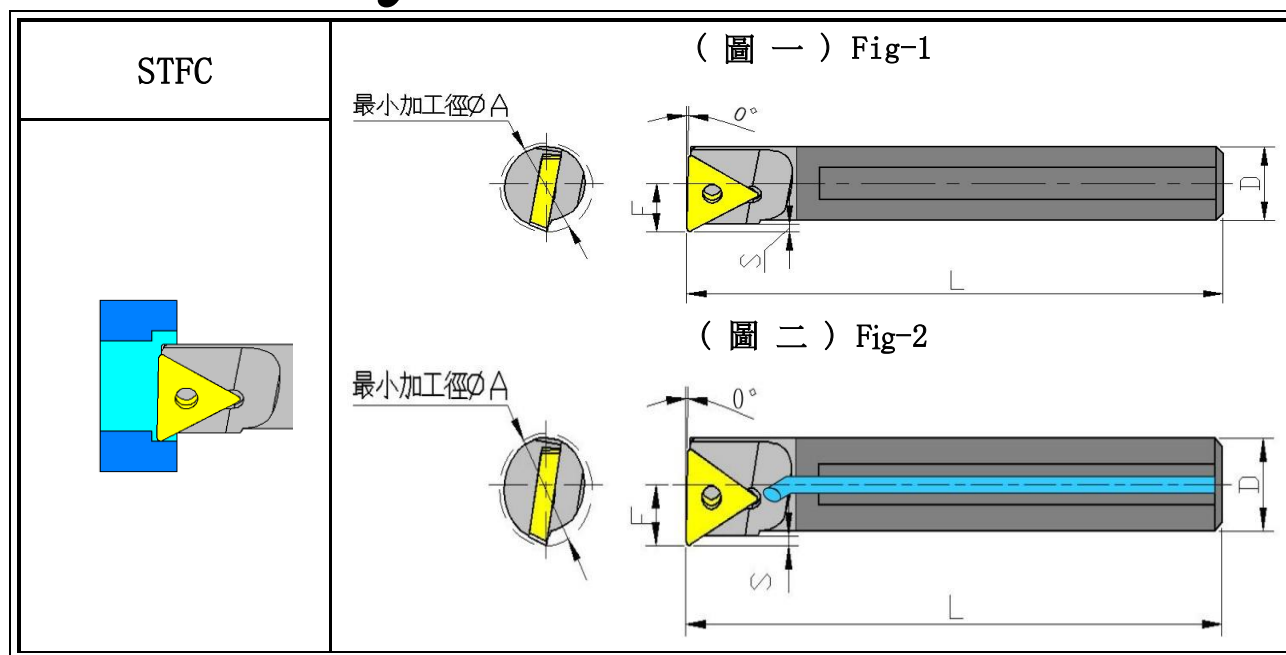

Stock	型號 Model No.	最小加工徑 A	F	D	L	S	螺絲 Screw	板手 Wrench	刀片 Insert
鎢鋼柄 (圖一) Carbide Shank (Fig-1)									
○	C06J-STFCR/L06-07	7	3.5	6	110	0.5	M2x3.7x2.6	T6	TC0604
●	C08K-STFCR/L09-10	10	5.5	8	125	1.5	M2.2x5.1x3.1	T7	TC0902
●	C10M-STFCR/L09-12	12	6	10	150	1			
○	C10M-STFCR/L11-12	12	6	10	150	1	M2.5x6.0x3.6	T8	TC1102
●	C12M-STFCR/L11-14	14	7.5	12	150	2			
●	C14Q-STFCR/L11-17	17	9	14	180	2			
●	C16R-STFCR/L11-18	18	9.5	16	200	2			
○	C20R-STFCR/L11-22	22	11	20	200	1	M4x8.8x5.4	T15	TC16T3
○	C16R-STFCR/L16-20	20	10	16	200	2			
○	C20R-STFCR/L16-22	22	11.5	20	200	3			
○	C25R-STFCR/L16-30	30	15	25	200	2.5			
○	C32S-STFCR/L16-38	38	20	32	250	4			
鎢鋼柄 + 水孔 (圖二) Carbide Shank With Coolant (Fig-2)									
●	E16R-STFCR/L11-18	18	9.5	16	200	2	M2.5x6.0x3.6	T8	TC1102
●	E20R-STFCR/L11-22	22	11	20	200	1			
合金鋼柄 (圖一) Alloy Steel (Fig-1)									
●	S08K-STFCR/L09-10	10	5.5	8	125	1.5	M2.2x5.1x3.1	T7	TC0902
●	S10K-STFCR/L09-12	12	6.5	10	125	1			

●	S10K-STFCR/L11-12	12	6.5	10	125	1	M2. 5x6. 0x3. 6	T8	TC1102
●	S12M-STFCR/L11-14	14	7.5	12	150	2			
●	S16Q-STFCR/L11-18	18	9.5	16	180	2			
○	S20R-STFCR/L11-22	22	11.5	20	200	1			
●	S20R-STFCR/L16-22	22	11.5	20	200	1	M4x8. 8x5. 4	T15	TC16T3

●:庫存 In Stock ○:非標準庫存(請確認交貨期) Non-standard Stock

Zy 內徑車刀 Boring Bars

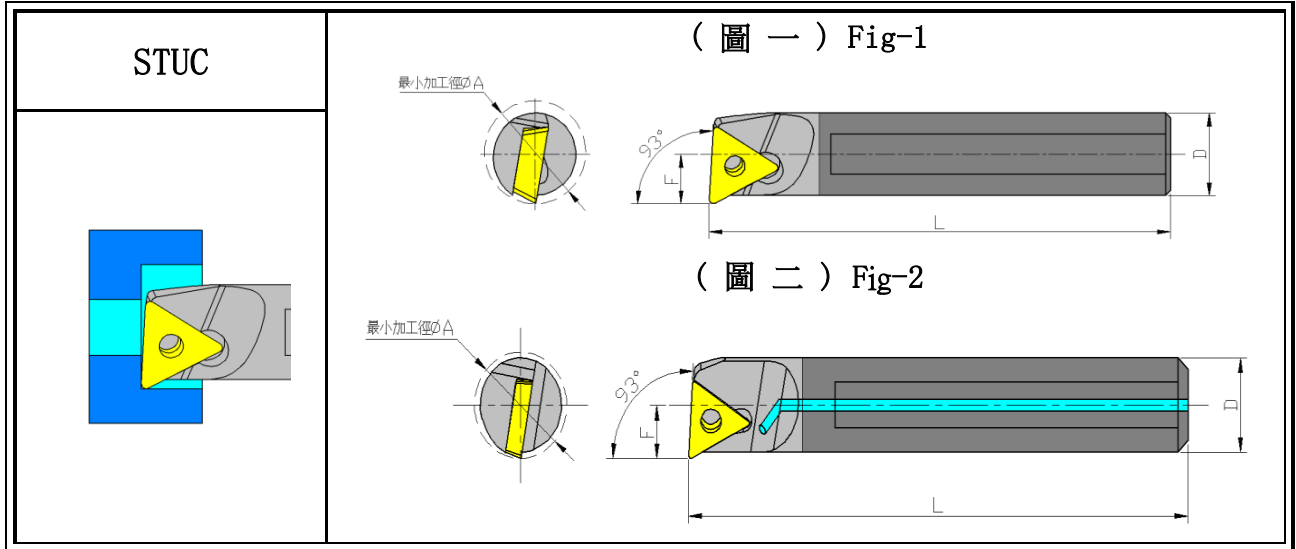

Stock	型號 Model No.	最小加工徑 A	F	D	L	螺絲 Screw	板手 Wrench	刀片 Insert
鎢鋼柄 (圖一) Carbide Shank (Fig-1)								
●	C06J-STUCR/L06-07	7	3.5	6	110	M2x3.7x2.6	T6	TC0601
●	C07J-STUCR/L06-08	8	4	7	110	M2x5.0x2.6		
○	C08K-STUCR/L06-10	10	4.5	8	125			
●	C08K-STUCR/L09-10	10	5	8	125	M2.2x5.1x3.1	T7	TC0902
●	C10M-STUCR/L09-12	12	6	10	150			
●	C12M-STUCR/L09-14	14	7	12	150			
●	C12Q-STUCR/L09-14	14	7	12	180			
●	C10M-STUCR/L11-12	12	6	10	150	M2.5x6.0x3.6	T8	TC1102
●	C12M-STUCR/L11-14	14	7	12	150			
●	C12Q-STUCR/L11-14	14	7	12	180			
●	C14M-STUCR/L11-16	16	8	14	150			
●	C16M-STUCR/L11-18	18	9	16	150			
●	C16R-STUCR/L11-18	18	9	16	200			
●	C20R-STUCR/L11-22	22	11	20	200			
●	C20S-STUCR/L11-22	22	11	20	250			
○	C25R-STUCR/L11-28	28	14	25	200			
●	C25S-STUCR/L11-28	28	14	25	250			
○	C20R-STUCR/L16T3-22	22	11	20	200	M4x8.8x5.4	T15	TC16T3
○	C25R-STUCR/L16T3-28	28	14	25	200			
○	C25S-STUCR/L16T3-28	28	14	25	250			

○	C32S-STUCR/L16T3-38	38	17.5	32	250						
鎢鋼柄 + 水孔 (圖二) Carbide Shank With Coolant (Fig-2)											
●	E06J-STUCR/L06-07	7	3.5	6	110	M2x3.7x2.6	T6	TC0601			
●	E08K-STUCR/L09-10	10	5	8	125	M2.2x5.1x3.1	T7	TC0902			
●	E10M-STUCR/L09-12	12	6	10	150						
●	E12M-STUCR/L09-14	14	7	12	150						
●	E10M-STUCR/L11-12	12	6	10	150	M2.5x6.0x3.6	T8	TC1102			
●	E12M-STUCR/L11-14	14	7	12	150						
●	E12Q-STUCR/L11-14	14	7	12	180						
●	E14M-STUCR/L11-16	16	8	14	150						
●	E14Q-STUCR/L11-16	16	8	14	180						
●	E16M-STUCR/L11-18	18	9	16	150						
●	E16R-STUCR/L11-18	18	9	16	200						
●	E20R-STUCR/L11-22	22	11	20	200						
●	E20S-STUCR/L11-22	22	11	20	250						
合金鋼柄 (圖一) Alloy Steel (Fig-1)											
●	S08K-STUCR/L09-10	10	5	8	125	M2.2x5.1x3.1	T7	TC0902			
●	S10K-STUCR/L09-12	12	6	10	125						
●	S12M-STUCR/L09-14	14	7	12	150						
●	S10K-STUCR/L11-12	12	6	10	125	M2.5x6.0x3.6	T8	TC1102			
●	S12M-STUCR/L11-14	14	7	12	150						
●	S14N-STUCR/L11-16	16	8	14	160						
●	S16Q-STUCR/L11-18	18	9	16	180						
●	S20R-STUCR/L11-22	22	11	20	200						
○	S20S-STUCR/L11-22	22	11	20	250						
●	S25R-STUCR/L11-28	28	14	25	200						
○	S25S-STUCR/L11-28	28	14	25	250						
●	S20R-STUCR/L16-22	22	11	20	200				M4x8.8x5.4	T15	TC16T3
●	S25R-STUCR/L16-28	28	14	25	200						
高硬度柄 (Y:圖二、Z:圖一) High Hardness Steel With Coolant (Y:Fig-1、Z:Fig-2)											
●	Y10K-STUCR/L09-12	12	6	10	125	M2.2x5.1x3.1	T7	TC0902			
●	Y12M-STUCR/L09-14	14	7	12	150						
●	Z08H-STUCR/L09-10	10	5	8	100						
●	Z12M-STUCR/L09-14	14	7	12	150						
●	Y10K-STUCR/L11-12	12	6	10	125	M2.5x6.0x3.6	T8	TC1102			
●	Y12M-STUCR/L11-14	14	7	12	150						
●	Y14N-STUCR/L11-16	16	8	14	160						
●	Y16N-STUCR/L11-18	18	9	16	160						
○	Y20R-STUCR/L11-22	22	11	20	200						

○	Y20S-STUCR/L11-22	22	11	20	250			
○	Y25R-STUCR/L11-28	28	14	25	200			
○	Y25S-STUCR/L11-28	28	14	25	250			
●	Z10K-STUCR/L11-12	12	6	10	125			
●	Z12M-STUCR/L11-14	14	7	12	150			
●	Z16M-STUCR/L11-18	18	9	16	150			
●	Z16Q-STUCR/L11-18	18	9	16	180			
●	Z20R-STUCR/L11-22	22	11	20	200			
●	Y25R-STUCR/L16T3-28	28	14	25	200	M4x8. 8x5. 4	T15	TC16T3
○	Y25S-STUCR/L16T3-28	28	14	25	200			
●	Y40T-STUCR/L16T3-43	43	21. 5	40	300			
●	Y50U-STUCR/L16T3-53	53	27	50	350			
●	Z25R-STUCR/L16T3-28	28	14	25	200			

●:庫存 In Stock ○:非標準庫存(請確認交貨期) Non-standard Stock

Zy 內徑車刀 Boring Bars

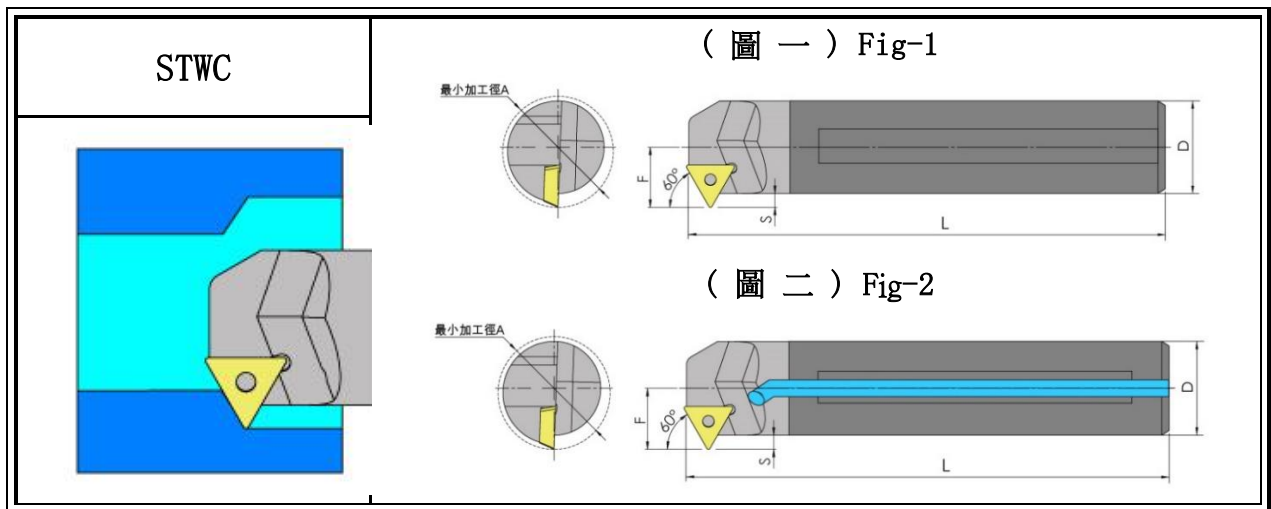

Stock	型號 Model No.	最小加工徑 A	F	D	L	S	螺絲 Screw	扳手 Wrench	刀片 Insert
鎢鋼柄 (圖一) Carbide Shank (Fig-1)									
●	C08K-STWCR/L06-10	10	5	8	125	1	M2x5.0x2.6	T6	TC0601
●	C08K-STWCR/L09-11	11	5.5	8	125	1.5	M2.2x5.1x3.1	T7	TC0902
●	C10M-STWCR/L11-14	14	8	10	150	3	M2.5x6.0x3.6	T8	TC1102
●	C12M-STWCR/L11-16	16	9	12	150	3			
●	C16M-STWCR/L11-20	20	11	16	150	3			
●	C16R-STWCR/L11-20	20	11	16	200	3			
○	C20R-STWCR/L11-25	25	13	20	200	3			
○	C20S-STWCR/L11-25	25	13	20	250	3			
○	C25R-STWCR/L11-31	31	15	25	200	2.5			
○	C32S-STWCR/L11-39	39	19	32	250	3			
合金鋼柄 (圖一) Alloy Steel (Fig-1)									
●	S08K-STWCR/L09-11	11	5.5	8	125	1.5	M2.2x5.1x3.1	T7	TC0902
●	S10K-STWCR/L11-14	14	8	10	125	3	M2.5x6.0x3.6	T8	TC1102
●	S12M-STWCR/L11-16	16	9	12	150	3			
●	S16Q-STWCR/L11-20	20	11	16	180	3			
●	S20R-STWCR/L11-25	25	13	20	200	3			
高硬度柄 (Y:圖二、Z:圖一) High Hardness Steel With Coolant (Y:Fig-1、Z:Fig-2)									
●	Y12M-STWCR/L11-16	16	9	12	150	3	M2.5x6.0x3.6	T8	TC1102
●	Y16N-STWCR/L11-20	20	11	16	150	3			
●	Y20R-STWCR/L11-25	25	13	20	250	3			

Zy 內徑車刀 Boring Bars

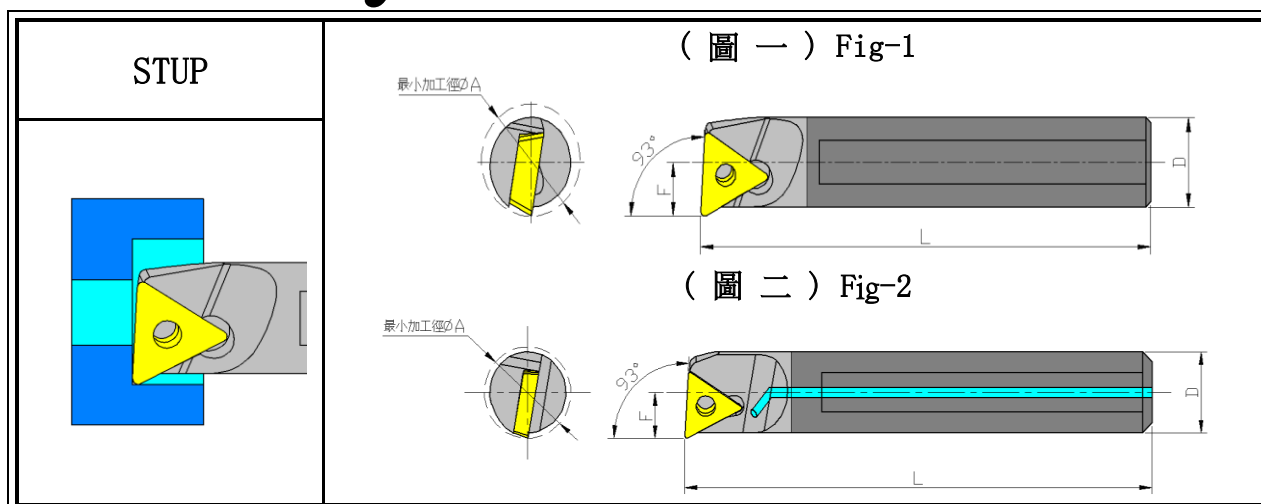

Stock	型號 Model No.	最小加工徑 A	F	D	L	螺絲 Screw	板手 Wrench	刀片 Insert
錐鋼柄 (圖一) Carbide Shank (Fig-1)								
●	C08K-STUPR/L08-10	10	5.5	8	125	M2.2x5.1x3.1	T7	TP0802
●	C10M-STUPR/L08-12	12	6.5	10	150			
●	C12M-STUPR/L08-14	14	7	12	150			
●	C16R-STUPR/L08-18	18	9	16	200			
●	C08K-STUPR/L09-10	10	5.5	8	125	M2.5x6.0x3.6	T8	TP0902
●	C10M-STUPR/L09-12	12	6.5	10	150			
●	C12M-STUPR/L09-14	14	7.5	12	150			
●	C12Q-STUPR/L09-14	14	7.5	12	180			
●	C10M-STUPR/L1102-12	12	6.5	10	150	M2.5x6.0x3.6	T8	TP1102
●	C12M-STUPR/L1102-14	14	7.5	12	150			
●	C16R-STUPR/L1102-18	18	9.5	16	200			
●	C10M-STUPR/L11-12	12	6.5	10	150	M3x7.8x4.1	T9	TP1103
●	C12M-STUPR/L11-14	14	7.5	12	150			
●	C12Q-STUPR/L11-14	14	7.5	12	180			
●	C14M-STUPR/L11-16	16	8.5	14	150			
●	C16M-STUPR/L11-18	18	9.5	16	150			
●	C16R-STUPR/L11-18	18	9.5	16	200			
●	C20R-STUPR/L11-22	22	11.5	20	200			
●	C20S-STUPR/L11-22	22	11.5	20	250			
○	C25R-STUPR/L11-30	30	15	25	200			
○	C25S-STUPR/L11-30	30	15	25	20			
○	C25R-STUPR/L1603-28	28	14	25	200	M4x8.8x5.4	T15	TP1603
○	C25S-STUPR/L1603-28	28	14	25	250			
○	C25R-STUPR/L16T3-28	28	14	25	200			

○	C25S-STUPR/L16T3-28	28	14	25	250			
○	C25R-STUPR/L1604-28	28	14	25	200	M4x8.8x5.4	T15	TP1604
○	C25S-STUPR/L1604-28	28	14	25	250			
鎢鋼柄 + 水孔 (圖二) Carbide Shank With Coolant (Fig-2)								
●	E08K-STUPR/L08-10	10	5.5	8	125	M2.2x5.1x3.1	T7	TP0802
●	E08K-STUPR/L09-10	10	5.5	8	125	M2.5x6.0x3.6	T8	TP0902
●	E10M-STUPR/L09-12	12	6.5	10	150			
●	E12M-STUPR/L09-14	14	7.5	12	150			
●	E10M-STUPR/L11-12	12	6.5	10	150	M3x7.8x4.1	T9	TP1103
●	E12M-STUPR/L11-14	14	7.5	12	150			
●	E12Q-STUPR/L11-14	14	7.5	12	180			
●	E14M-STUPR/L11-16	16	8.5	14	150			
●	E14Q-STUPR/L11-16	16	8.5	14	180			
●	E16M-STUPR/L11-18	18	9.5	16	150			
●	E16R-STUPR/L11-18	18	9.5	16	200			
●	E20R-STUPR/L11-22	22	11.5	20	200			
●	E20S-STUPR/L11-22	22	11.5	20	250			
合金鋼柄 (圖一) Alloy Steel (Fig-1)								
●	S08K-STUPR/L08-10	10	5.5	8	125	M2.2x5.1x3.1	T7	TP0802
●	S10K-STUPR/L08-12	12	6.5	10	125			
●	S08K-STUPR/L09-10	10	5.5	8	125	M2.5x6.0x3.6	T8	TP0902
●	S10K-STUPR/L09-12	12	6.5	10	125			
●	S12M-STUPR/L09-14	14	7.5	12	150			
●	S10K-STUPR/L11-12	12	6.5	10	125	M3x7.8x4.1	T9	TP1103
●	S12M-STUPR/L11-14	14	7.5	12	150			
●	S14N-STUPR/L11-16	16	8.5	14	160			
●	S16Q-STUPR/L11-18	18	9.5	16	180			
●	S20R-STUPR/L11-22	22	11.5	20	200			
●	S25R-STUPR/L11-30	30	15	25	200			
○	S25R-STUPR/L16-32	32	16	25	200	M4x8.8x5.4	T15	TP1604
高硬度柄 (Y:圖二、Z:圖一) High Hardness Steel With Coolant (Y:Fig-1、Z:Fig-2)								
●	Y10K-STUPR/L09-12	12	6.5	10	125	M2.5x6.0x3.6	T8	TP0902
●	Y12M-STUPR/L09-14	14	7.5	12	150			
●	Z08H-STUPR/L09-10	10	5.5	8	100			
●	Z10H-STUPR/L09-12	12	6.5	10	125			
●	Y10K-STUPR/L11-12	12	6.5	10	125	M3x7.8x4.1	T9	TP1103
●	Y12M-STUPR/L11-14	14	7.5	12	150			
○	Y14N-STUPR/L11-16	16	8.5	14	150			
●	Y16N-STUPR/L11-18	18	9.5	16	160			

●	Y20R-STUPR/L11-22	22	11.5	20	200			
●	Y25R-STUPR/L11-30	30	15	25	200			
○	Z12M-STUPR/L11-14	14	7.5	12	150			
○	Z16M-STUPR/L11-18	18	9.5	16	150			
○	Z16Q-STUPR/L11-18	18	9.5	16	180			
●	Z20R-STUPR/L11-22	22	11.5	20	200			
●	Y25R-STUPR/L1603-28	28	14	25	200	M4x8.8x5.4	T15	TP1603
●	Y32S-STUPR/L1603-38	38	17.5	32	250			
●	Z25R-STUPR/L1603-28	28	14	25	200			
●	Y25R-STUPR/L16T3-28	28	14	25	200	M4x8.8x5.4	T15	TP16T3
●	Y20R-STUPR/L1604-25	25	13	20	200	M4x8.8x5.4	T15	TP1604
●	Y25R-STUPR/L1604-28	28	14	25	200			
●	Z20R-STUPR/L1604-25	25	13	20	200			
●	Z25R-STUPR/L1604-28	28	14	25	200			

●:庫存 In Stock ○:非標準庫存(請確認交貨期) Non-standard Stock

Zy 內徑車刀 Boring Bars

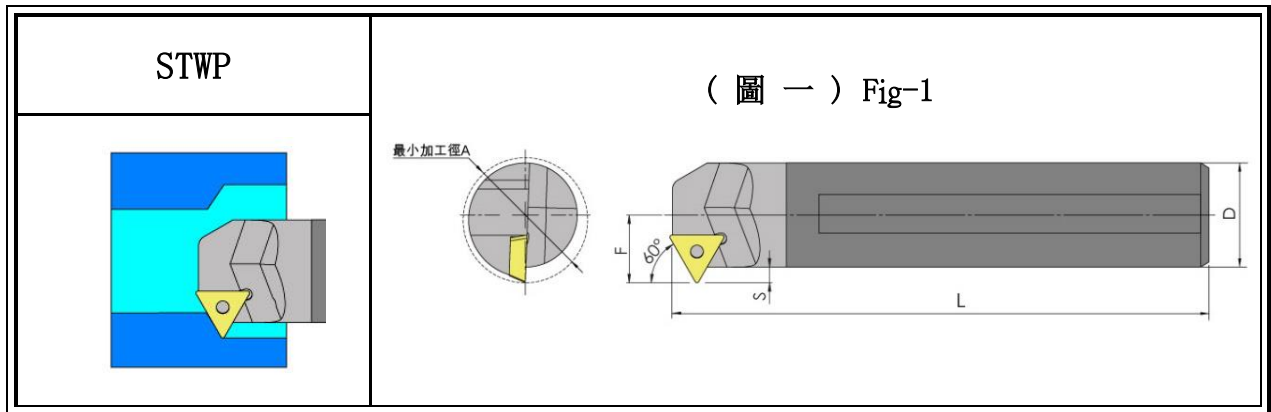

Stock	型號 Model No.	最小加工徑 A	F	D	L	S	螺絲 Screw	扳手 Wrench	刀片 Insert
鎢鋼柄 (圖一) Carbide Shank (Fig-1)									
●	C10M-STWPR/L11-13	13	7.5	10	125	2.5	M2.5x6.0x3.6	T8	TP1103
●	C12M-STWPR/L11-16	16	9	12	150	3			
○	C16M-STWPR/L11-20	20	11	16	150	3			
●	C16R-STWPR/L11-20	20	11	16	200	3			
○	C20R-STWPR/L11-25	25	13	20	200	3			
合金鋼柄 (圖一) Alloy Steel (Fig-1)									
●	S10K-STWPR/L11-13	13	7.5	10	125	2.5	M2.5x6.0x3.6	T8	TP1103
●	S12M-STWPR/L11-16	16	9	12	150	3			
●	S16Q-STWPR/L11-20	20	11	16	180	3			
●	S20R-STWPR/L11-25	25	13	20	200	3			

●:庫存 In Stock ○:非標準庫存(請確認交貨期) Non-standard Stock

Zy 內徑車刀 Boring Bars

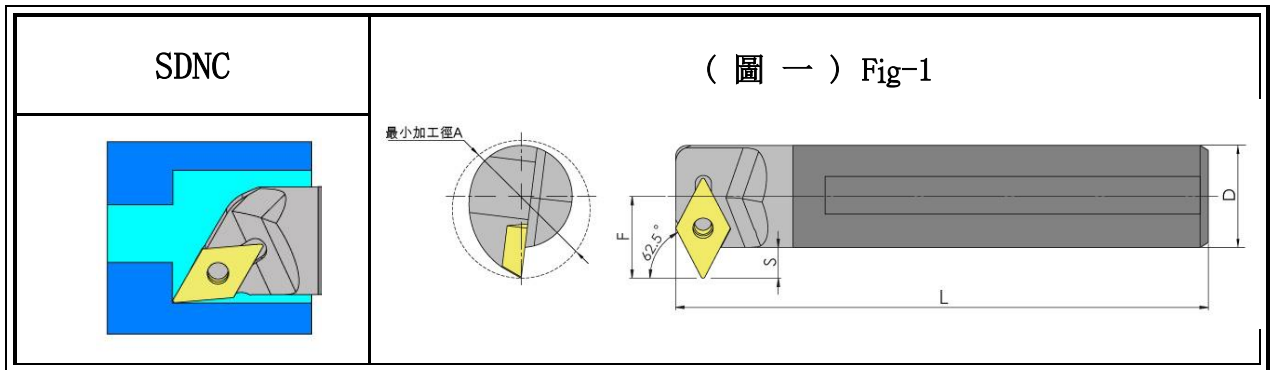

Stock	型號 Model No.	最小加工徑 A	F	D	L	 螺絲 Screw	 板手 Wrench	刀片 Insert
合金鋼柄 (圖一) Alloy Steel (Fig-1)								
●	S16Q-SDNCR/L07-20	20	11	16	180	M2.5x6.0x3.6	T8	DC0702
●	S20R-SDNCR/L11-27	27	16	20	250	M4x8.8x5.4	T15	DC11T3

●:庫存 In Stock ○:非標準庫存(請確認交貨期) Non-standard Stock

Zy 內徑車刀 Boring Bars

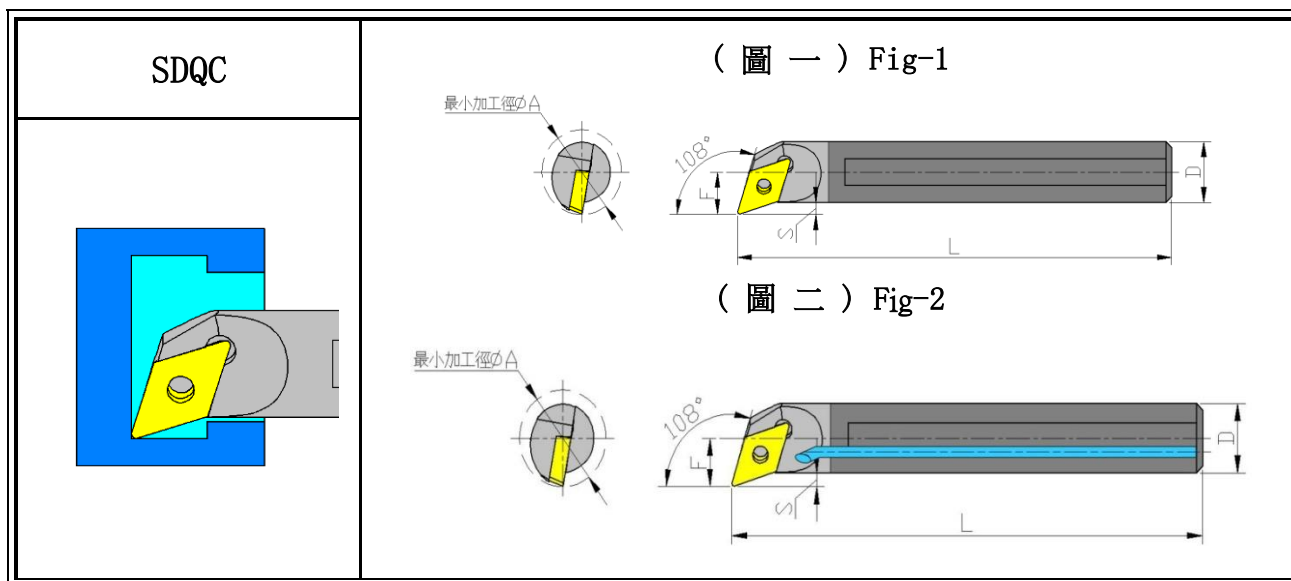



Stock	型號 Model No.	最小加工徑 A	F	D	L	S	螺絲 Screw	板手 Wrench	刀片 Insert
鎢鋼柄 (圖一) Carbide Shank (Fig-1)									
●	C10M-SDQCR/L07-13	13	7	10	150	2	M2.5x6.0x3.6	T8	DC0702
●	C12M-SDQCR/L07-16	16	9	12	150	3			
●	C12Q-SDQCR/L07-16	16	9	12	180	3			
●	C14M-SDQCR/L07-18	18	10	14	150	3			
●	C16M-SDQCR/L07-20	20	11	16	150	3			
●	C16R-SDQCR/L07-20	20	11	16	200	3			
●	C16M-SDQCR/L11-20	20	11	16	150	3	M4x8.8-5.4	T15	DC11T3
●	C16R-SDQCR/L11-20	20	11	16	200	3			
●	C20R-SDQCR/L11-25	25	13	20	200	3			
●	C20S-SDQCR/L11-25	25	13	20	250	3			
○	C25R-SDQCR/L11-32	32	17	25	200	4.5			
●	C25S-SDQCR/L11-32	32	17	25	250	4.5			
○	C32S-SDQCR/L11-40	40	20	32	250	4			
鎢鋼柄 + 水孔 (圖二) Carbide Shank With Coolant (Fig-2)									
●	E10M-SDQCR/L07-13	13	7	10	150	2	M2.5x6.0x3.6	T8	DC0702
●	E12M-SDQCR/L07-16	16	9	12	150	3			
●	E12Q-SDQCR/L07-16	16	9	12	180	3			
●	E14M-SDQCR/L07-18	18	10	14	150	3			
●	E16M-SDQCR/L07-20	20	11	16	150	3			

●	E16R-SDQCR/L07-20	20	11	16	200	3			
●	E16M-SDQCR/L11-20	20	11	16	150	3	M4x8. 8x-5. 4	T15	DC11T3
●	E16R-SDQCR/L11-20	20	11	16	200	3			
●	E20R-SDQCR/L11-25	25	13	20	200	3			
●	E20S-SDQCR/L11-25	25	13	20	250	3			
●	E25R-SDQCR/L11-32	32	17	25	200	4. 5			
●	E25S-SDQCR/L11-32	32	17	25	250	4. 5			
●	E32S-SDQCR/L11-40	40	20	32	250	4			
合金鋼柄 (圖一) Alloy Steel (Fig-1)									
●	S10K-SDQCR/L07-13	13	7	10	125	2	M2. 5x6. 0x3. 6	T8	DC0702
●	S12M-SDQCR/L07-16	16	9	12	150	3			
●	S14N-SDQCR/L07-18	18	10	14	160	3			
●	S16Q-SDQCR/L07-20	20	11	16	180	3			
●	S16Q-SDQCR/L11-20	20	11	16	180	3	M4x8. 8x5. 4	T15	DC11T3
●	S20R-SDQCR/L11-25	25	13	20	200	3			
●	S25R-SDQCR/L11-32	32	17	25	250	4. 5			
高硬度柄 (Y:圖二、Z:圖一) High Hardness Steel With Coolant (Y:Fig-1、Z:Fig-2)									
●	Y10K-SDQCR/L07-13	13	7	10	125	2	M2. 5x6. 0x3. 6	T8	DC0702
●	Y12M-SDQCR/L07-16	16	9	12	150	3			
○	Y14N-SDUCR/L07-18	18	10	14	160	3			
●	Y16N-SDQCR/L07-20	20	11	16	160	3			
●	Y16Q-SDQCR/L07-20	20	11	16	180	3			
○	Y20R-SDQCR/L07-25	25	13	20	200	3			
●	Z10K-SDQCR/L07-13	13	7	10	125	2			
●	Z20R-SDQCR/L07-25	25	13	20	200	3			
●	Y16N-SDQCR/L11-20	20	11	16	160	3	M4x8. 8-5. 4	T15	DC11T3
○	Y16Q-SDQCR/L11-20	20	11	16	180	3			
●	Y20R-SDQCR/L11-25	25	13	20	200	3			
●	Y25R-SDQCR/L11-32	32	17	25	250	4. 5			
●	Y40T-SDQCR/L11-46	46	25	40	300	5			
●	Y50U-SDQCR/L11-56	56	30	50	350	5			
○	Z16N-SDQCR/L11-20	20	11	16	160	3			
○	Z16Q-SDQCR/L11-20	20	11	16	180	3			

●:庫存 In Stock ○:非標準庫存(請確認交貨期) Non-standard Stock

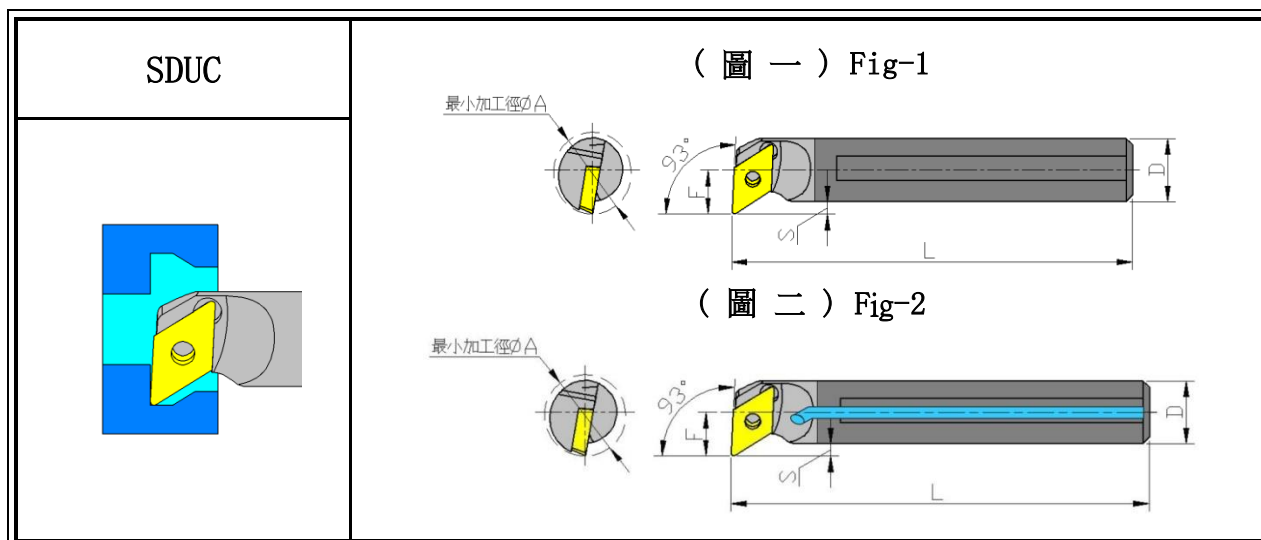
Zy 內徑車刀 Boring Bars



Stock	型號 Model No.	最小加工徑 A	F	D	L	S	 螺絲 Screw	 板手 Wrench	刀片 Insert
鎢鋼柄 (圖一) Carbide Shank (Fig-1)									
●	C10M-SDUCR/L07-13	13	7	10	150	2	M2.5x6.0x3.6	T8	DC0702
●	C12M-SDUCR/L07-16	16	9	12	150	3			
●	C12Q-SDUCR/L07-16	16	9	12	180	3			
●	C14M-SDUCR/L07-18	18	10	14	150	3			
●	C16M-SDUCR/L07-20	20	11	16	150	3			
●	C16R-SDUCR/L07-20	20	11	16	200	3			
●	C20R-SDUCR/L07-25	25	13	20	200	3			
●	C16M-SDUCR/L11-20	20	11	16	150	3	M4x8.8x5.4	T15	DC11T3
●	C16R-SDUCR/L11-20	20	11	16	200	3			
●	C20R-SDUCR/L11-23	23	12.5	20	200	2.5			
●	C20S-SDUCR/L11-23	23	12.5	20	250	2.5			
●	C25R-SDUCR/L11-32	32	17	25	200	4.5			
●	C25S-SDUCR/L11-32	32	17	25	250	4.5			
○	C32S-SDUCR/L11-40	40	20	32	250	4			
鎢鋼柄 + 水孔 (圖二) Carbide Shank With Coolant (Fig-2)									
●	E10M-SDUCR/L07-13	13	7	10	150	2	M2.5x6.0x3.6	T8	DC0702
●	E12M-SDUCR/L07-16	16	9	12	150	3			
●	E12Q-SDUCR/L07-16	16	9	12	180	3			
●	E14M-SDUCR/L07-18	18	10	14	150	3			
●	E14Q-SDUCR/L07-18	18	10	14	180	3			

●	E16M-SDUCR/L07-20	20	11	16	150	3			
●	E16R-SDUCR/L07-20	20	11	16	200	3			
●	E20R-SDUCR/L07-25	25	13	20	200	3			
●	E16M-SDUCR/L11-20	20	11	16	150	3	M4x8. 8x5. 4	T15	DC11T3
●	E16R-SDUCR/L11-20	20	11	16	200	3			
●	E20R-SDUCR/L11-23	23	12. 5	20	200	2. 5			
●	E20S-SDUCR/L11-23	23	12. 5	20	250	2. 5			
●	E25R-SDUCR/L11-32	32	17	25	200	4. 5			
●	E25S-SDUCR/L11-32	32	17	25	250	4. 5			
○	E32S-SDUCR/L11-40	40	20	32	250	4			
合金鋼柄 (圖一) Alloy Steel (Fig-1)									
●	S10K-SDUCR/L07-13	13	7	10	125	2	M2. 5x6. 0x3. 4	T8	DC0702
●	S12M-SDUCR/L07-16	16	9	12	150	3			
●	S14N-SDUCR/L07-18	18	10	14	160	3			
●	S16Q-SDUCR/L07-20	20	11	16	180	3			
●	S20R-SDUCR/L07-25	25	13	20	200	3			
●	S16Q-SDUCR/L11-20	20	11	16	180	3	M4x8. 8x5. 4	T15	DC11T3
●	S20R-SDUCR/L11-25	25	13	20	200	3			
●	S25S-SDUCR/L11-32	32	17	25	250	4. 5			
高硬度柄 (Y:圖二、Z:圖一) High Hardness Steel With Coolant (Y:Fig-1、Z:Fig-2)									
●	Y10K-SDUCR/L07-13	13	7	10	125	2	M2. 5x6. 0x3. 6	T8	DC0702
●	Y12M-SDUCR/L07-16	16	9	12	150	3			
○	Y14N-SDUCR/L07-18	18	10	14	160	3			
●	Y16N-SDUCR/L07-20	20	11	16	160	3			
○	Y16Q-SDUCR/L07-20	20	11	16	180	3			
●	Z10H-SDUCR/L07-13	13	7	10	125	2			
○	Z12M-SDUCR/L07-16	16	9	12	150	3			
●	Z16Q-SDUCR/L07-20	20	11	16	180	3			
●	Y16N-SDUCR/L11-20	20	11	16	160	3	M4x8. 8x5. 4	T15	DC11T3
●	Y16Q-SDUCR/L11-20	20	11	16	180	3			
●	Y20R-SDUCR/L11-23	23	12. 5	20	200	2. 5			
○	Y20S-SDUCR/L11-23	23	12. 5	20	250	2. 5			
●	Y25R-SDUCR/L11-32	32	17	25	200	4. 5			
●	Y32S-SDUCR/L11-37	37	20	32	250	4			
●	Y40T-SDUCR/L11-46	46	25	40	300	5			
●	Y50U-SDUCR/L11-56	56	30	50	350	5			
●	Z16M-SDUCR/L11-20	20	11	16	150	3			
●	Z20R-SDUCR/L11-23	23	12. 5	20	200	2. 5			
●	Z25R-SDUCR/L11-32	32	17	25	200	4. 5			

Zy 內徑車刀 Boring Bars

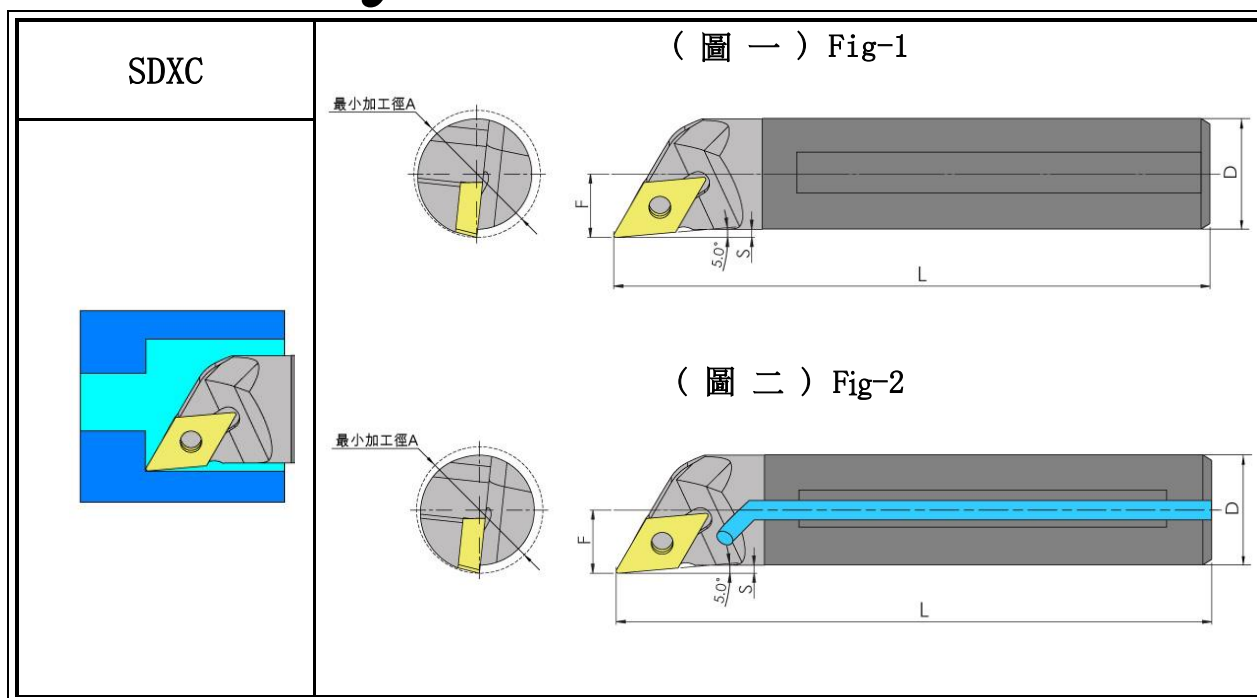

Stock	型號 Model No.	最小加工徑 A	F	D	L	螺絲 Screw	板手 Wrench	刀片 Insert
鑄鋼柄 (圖一) Carbide Shank (Fig-1)								
●	C08K-SDXCR/L07-10	10	5	8	125	M2. 5x6. 0x3. 6	T8	DC0702
●	C10M-SDXCR/L07-12	12	6	10	150			
●	C12M-SDXCR/L07-14	14	7	12	150			
●	C14M-SDXCR/L07-16	16	8	14	150			
●	C16M-SDXCR/L07-18	18	9	16	150			
●	C16R-SDXCR/L07-18	18	9	16	200			
●	C16M-SDXCR/L11-18	18	9	16	200	M4x8. 8x5. 4	T15	DC11T3
●	C20R-SDXCR/L11-25	25	11. 5	20	200			
●	C20S-SDXCR/L11-25	25	11. 5	20	250			
○	C25R-SDXCR/L11-32	32	14	25	200			
○	C25S-SDXCR/L11-32	32	14	25	250			
鑄鋼柄 + 水孔 (圖二) Carbide Shank With Coolant (Fig-2)								
●	E08K-SDXCR/L07-10	10	5	8	125	M2. 5x6. 0x3. 6	T8	DC0702
●	E10M-SDXCR/L07-12	12	6	10	150			
●	E12M-SDXCR/L07-14	14	7	12	150			
●	E16M-SDXCR/L07-18	18	9	16	150			
●	E16R-SDXCR/L07-18	18	9	16	200			

合金鋼柄 (圖一) Alloy Steel (Fig-1)								
●	S08K-SDXCR/L07-10	10	5	8	125	M2. 5x6. 0x3. 6	T8	DC0702
●	S10K-SDXCR/L07-12	12	6	10	125			
●	S12M-SDXCR/L07-14	14	7	12	150			
●	S16Q-SDXCR/L07-18	18	9	16	180			
●	S16Q-SDXCR/L11-18	18	9	16	180	M4x8. 8x5. 4	T15	DC11T3
●	S20R-SDXCR/L11-25	25	11. 5	20	250			
○	S25R-SDXCR/L11-32	32	14	25	200			
高硬度柄 (Y:圖二、Z:圖一) High Hardness Steel With Coolant (Y:Fig-1、Z:Fig-2)								
●	Y12M-SDXCR/L07-14	14	7	12	150	M2. 5x6. 0x3. 6	T8	DC0702
●	Y16N-SDXCR/L07-18	18	9	16	180			
●	Z25R-SDXCR/L11-28	28	14	25	250	M4x8. 8x5. 4	T15	DC11T3

●:庫存 In Stock ○:非標準庫存(請確認交貨期) Non-standard Stock

Zy 內徑車刀 Boring Bars

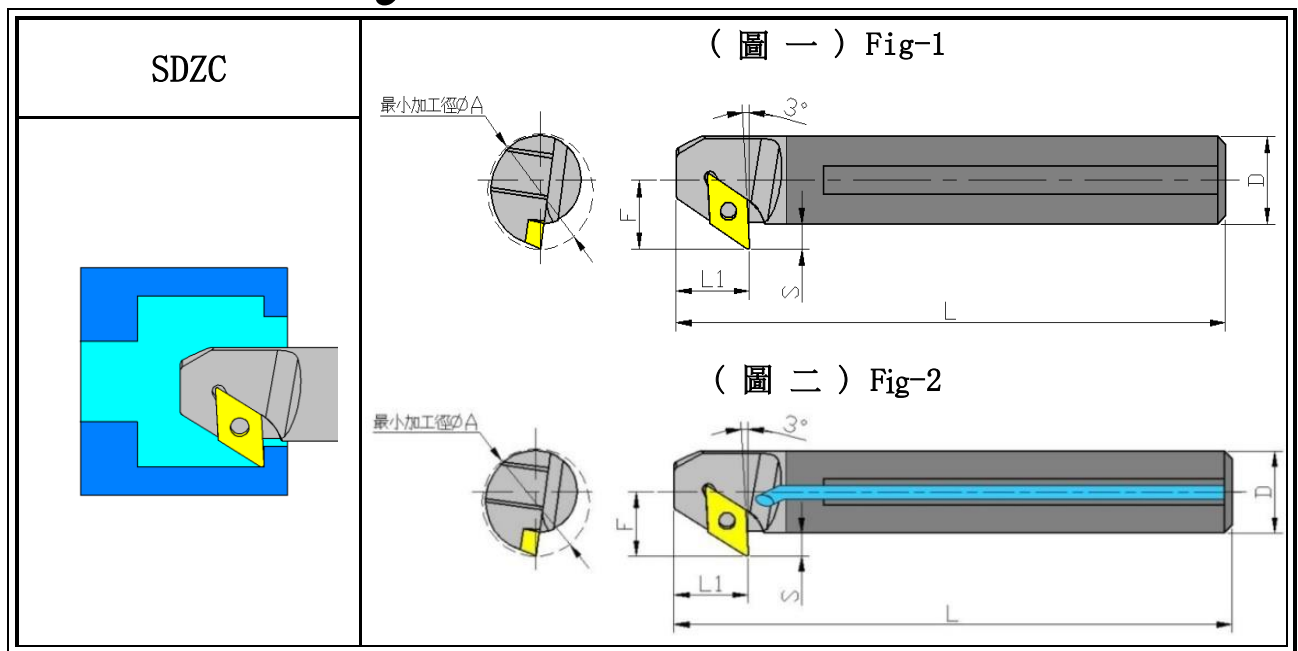

Stock	型號 Model No.	最小加工徑 A	F	D	L	S	螺絲 Screw	扳手 Wrench	刀片 Insert
鎢鋼柄 (圖一) Carbide Shank (Fig-1)									
●	C10M-SDZCR/L07-15	15	8.5	10	150	3.5	M2.5x6.0x3.6	T8	DC0702
●	C12M-SDZCR/L07-17	17	10.5	12	150	4.5			
●	C12Q-SDZCR/L07-17	17	10.5	12	180	4.5			
●	C16M-SDZCR/L07-21	21	12.5	16	150	4.5			
●	C16R-SDZCR/L07-21	21	12.5	16	200	4.5			
○	C20R-SDZCR/L07-26	26	15.5	20	200	5.5	M4x8.8x5.4	T15	DC11T3
●	C20R-SDZCR/L11-26	26	15.5	20	200	5.5			
○	C20S-SDZCR/L11-26	26	15.5	20	250	5.5			
○	C25R-SDZCR/L11-33	33	18	25	200	5.5			
○	C25S-SDZCR/L11-33	33	18	25	250	5.5			
○	C32S-SDZCR/L11-40	40	23	32	250	7			
鎢鋼柄 + 水孔 (圖二) Carbide Shank With Coolant (Fig-2)									
●	E10M-SDZCR/L07-15	15	8.5	10	150	3.5	M2.5x6.0x3.6	T8	DC0702
●	E12M-SDZCR/L07-17	17	10.5	12	150	4.5			
●	E16M-SDZCR/L07-21	21	12.5	16	150	4.5			
●	E16R-SDZCR/L07-21	21	12.5	16	200	4.5			
●	E20R-SDZCR/L11-26	26	15.5	20	200	5.5	M4x8.8x5.4	T15	DC11T3
○	E25R-SDZCR/L11-33	33	18	25	200	5.5			

○	E32S-SDZCR/L11-40	40	21.5	32	250	5.5			
合金鋼柄 (圖一) Alloy Steel (Fig-1)									
●	S10K-SDZCR/L07-15	15	8.5	10	125	3.5	M2.5x6.0x3.6	T8	DC0702
●	S12M-SDZCR/L07-17	17	10.5	12	150	4.5			
●	S16Q-SDZCR/L07-21	21	12.5	16	180	4.5			
●	S20R-SDZCR/L07-26	26	15.5	20	200	5.5			
●	S20R-SDZCR/L11-26	26	15.5	20	200	5.5	M4x8.8x5.4	T15	DC11T3
○	S25R-SDZCR/L11-33	33	18	25	200	5.5			
高硬度柄 (Y:圖二、Z:圖一) High Hardness Steel With Coolant (Y:Fig-1、Z:Fig-2)									
●	Y12M-SDZCR/L07-17	17	10.5	12	150	4.5	M2.5x6.0x3.6	T8	DC0702
●	Y16N-SDZCR/L07-21	21	12.5	16	160	4.5			
●	Y16Q-SDZCR/L07-21	21	12.5	16	180	4.5			
○	Z16R-SDZCR/L07-21	21	12.5	16	200	4.5			
●	Y20R-SDZCR/L11-26	26	15.5	20	200	5.5	M4x8.8x5.4	T15	DC11T3
●	Y25R-SDZCR/L11-33	33	18	25	200	5.5			

●:庫存 In Stock ○:非標準庫存(請確認交貨期) Non-standard Stock

Zy 內徑車刀 Boring Bars

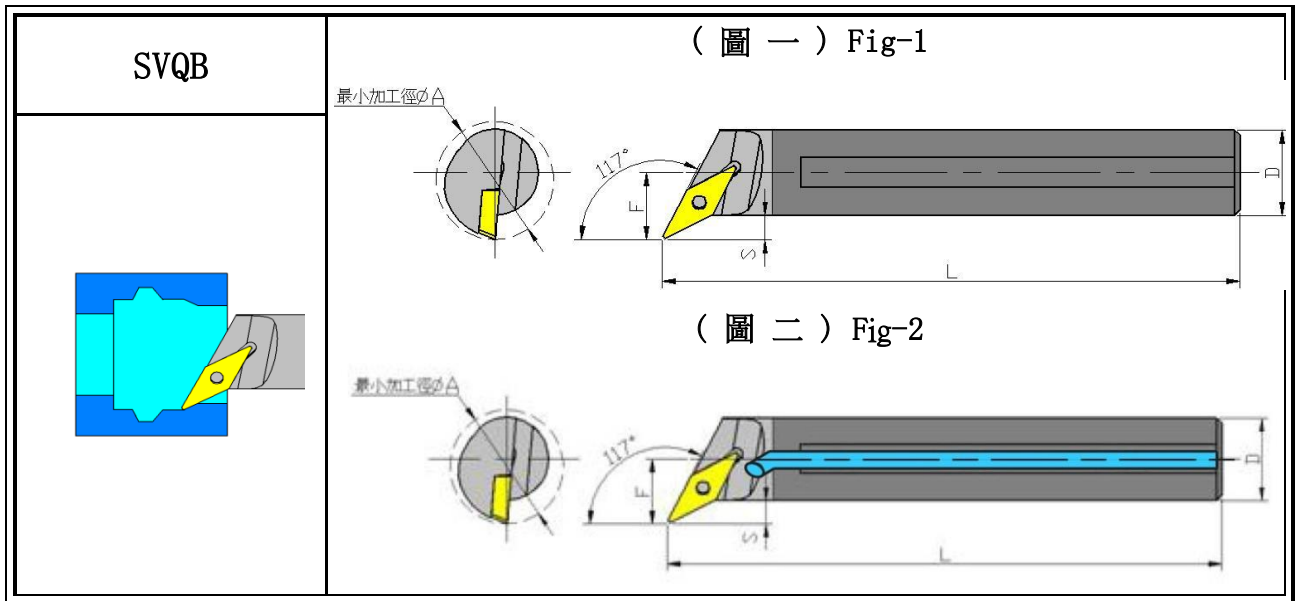

Stock	型號 Model No.	最小加工徑 A	F	D	L	螺絲 Screw	扳手 Wrench	刀片 Insert
錫鋼柄 (圖一) Carbide Shank (Fig-1)								
●	C12M-SVQBR/L11-18	18	11	12	150	M2.5x6.0x3.6	T8	VB1103
●	C16M-SVQBR/L11-22	22	12.5	16	150			
合金鋼柄 (圖一) Alloy Steel (Fig-1)								
●	S12M-SVQBR/L11-18	18	11	12	150	M2.5x6.0x3.6	T8	VB1103
●	S16Q-SVQBR/L11-22	22	12.5	16	180			
●	S20R-SVQCR/L11-25	25	14	20	200			
高硬度柄 (Y:圖二、Z:圖一) High Hardness Steel With Coolant (Y:Fig-1、Z:Fig-2)								
●	Y40T-SVQBR/L16-47	47	25.5	12	300	M3.5x11.4x5.7	T15	VB1604

●:庫存 In Stock ○:非標準庫存(請確認交貨期) Non-standard Stock

Zy 內徑車刀 Boring Bars

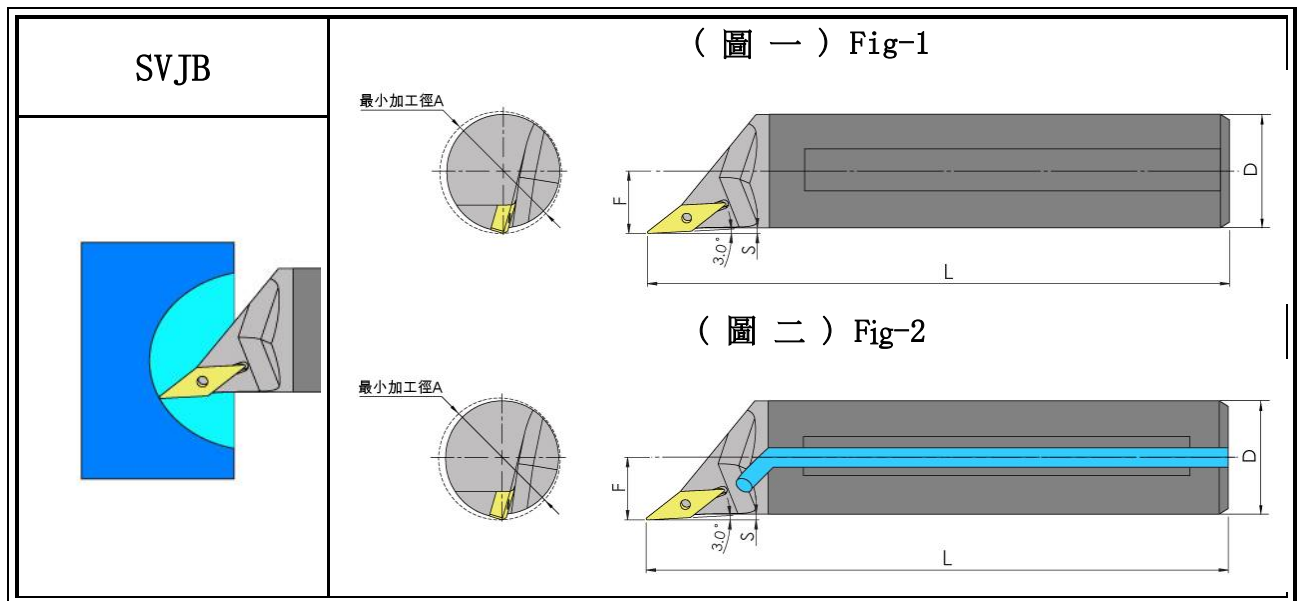

Stock	型號 Model No.	最小加工徑 A	F	D	L	螺絲 Screw	扳手 Wrench	刀片 Insert
鎢鋼柄 (圖一) Carbide Shank (Fig-1)								
●	C10M-SVJBR/L11-12	12	6	10	150	M2. 5x6. 0x3. 6	T8	VB1103
●	C12M-SVJBR/L11-14	14	7	12	150			
●	C16R-SVJBR/L11-18	18	9	16	200			
○	C20R-SVJBR/L11-22	22	11	20	200			
合金鋼柄 (圖一) Alloy Steel (Fig-1)								
●	S10K-SVJBR/L11-12	12	6	10	125	M2. 5x6. 0x3. 6	T8	VB1103
●	S12M-SVJBR/L11-14	14	7	12	150			
●	S16Q-SVJBR/L11-18	18	9	16	180			
●	S20R-SVJBR/L11-22	22	11	20	200			
高硬度柄 (Y:圖二、Z:圖一) High Hardness Steel With Coolant (Y:Fig-1、Z:Fig-2)								
●	Y40T-SVJBR/L16-47	47	25. 5	12	300	M3. 5x11. 4x5. 7	T15	VB1604

●:庫存 In Stock ○:非標準庫存(請確認交貨期) Non-standard Stock

Zy 內徑車刀 Boring Bars

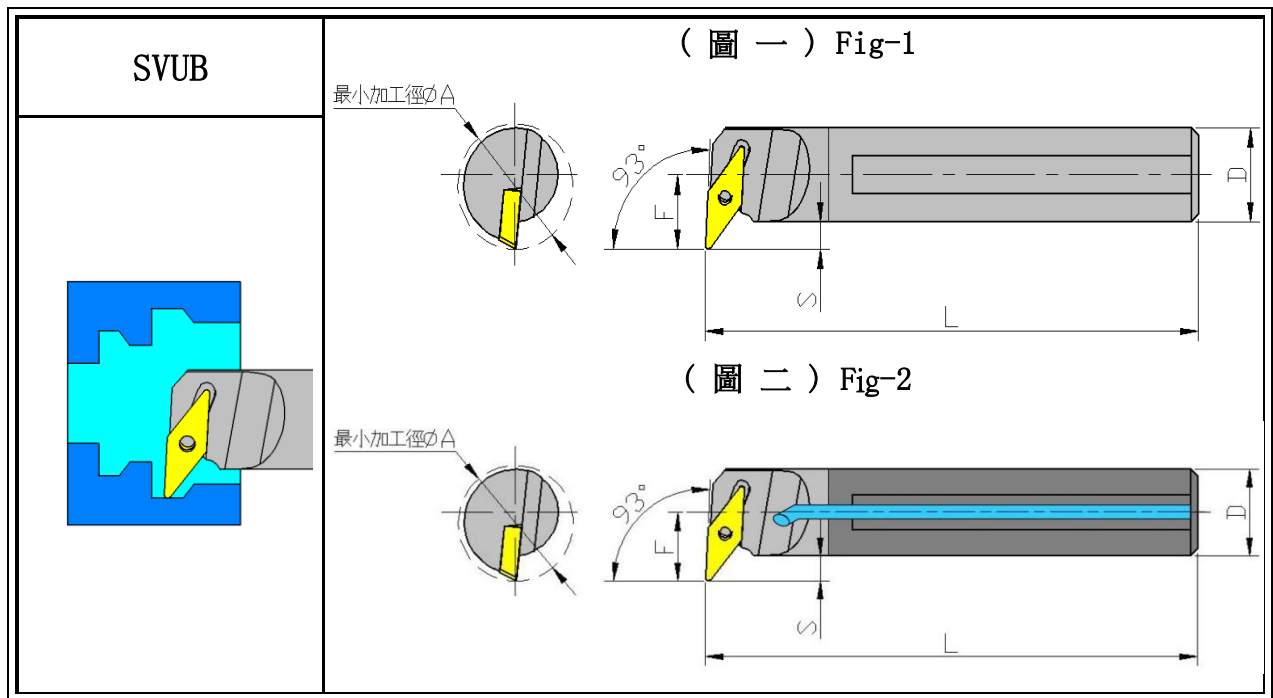

Stock	型號 Model No.	最小加工徑 A	F	D	L	S	螺絲 Screw	扳手 Wrench	刀片 Insert
錫鋼柄 (圖一) Carbide Shank (Fig-1)									
●	C16M-SVUBR/L11-22	22	12.5	16	150	4.5	M2.5x6.0x3.6	T8	VB1103
●	C16R-SVUBR/L11-22	22	12.5	16	200	4.5			
●	C20R-SVUBR/L11-27	27	15	20	200	5			
錫鋼柄 + 水孔 (圖二) Carbide Shank With Coolant (Fig-2)									
●	E16R-SVUBR/L11-22	22	12.5	16	200	4.5	M2.5x6.0x3.6	T8	VB1103
●	E20R-SVUBR/L11-27	27	15	20	200	5			
合金鋼柄 (圖一) Alloy Steel (Fig-1)									
●	S16Q-SVUBR/L11-22	22	12.5	16	180	4.5	M2.5x6.0x3.6	T8	VB1103
●	S20R-SVUBR/L11-27	27	15	20	200	5			
●	S20R-SVUBR/L16-31	31	19	20	200	9	M3.5x12.0x5.4	T15	VB1604
高硬度柄 (Y:圖二、Z:圖一) High Hardness Steel With Coolant (Y:Fig-2、Z:Fig-1)									
●	Y40T-SVUBR/L16-48	27	12.5	16	300	7	M3.5x11.4x5.7	T8	VB1604

●:庫存 In Stock ○:非標準庫存(請確認交貨期) Non-standard Stock

Zy 內徑車刀 Boring Bars

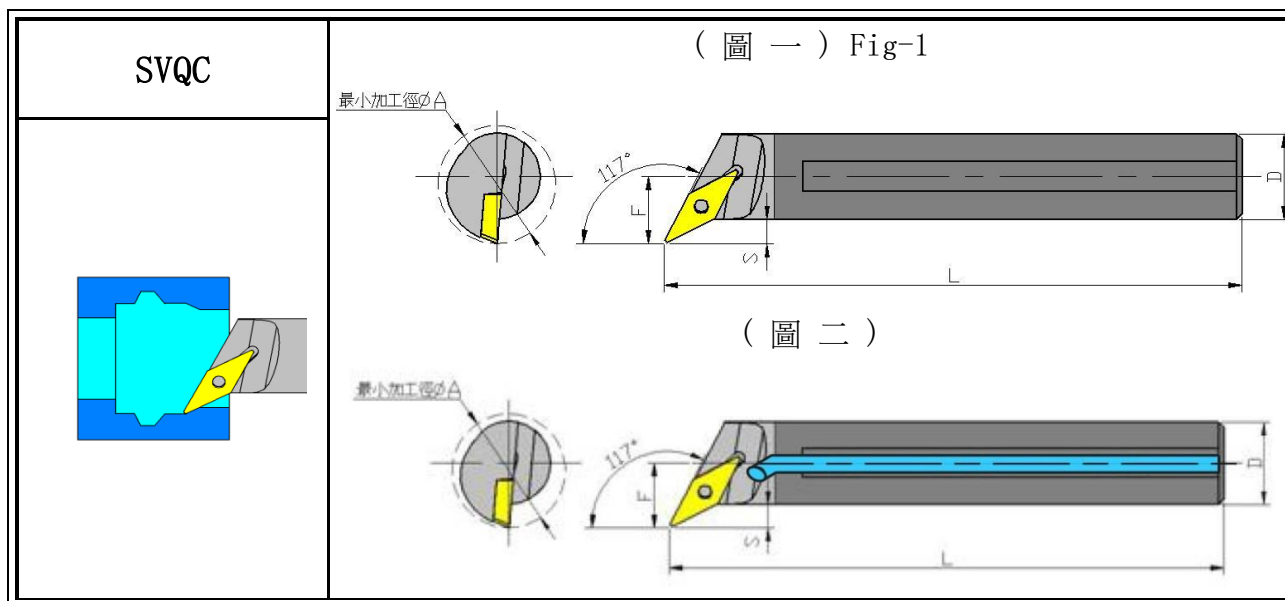

Stock	型號 Model No.	最小加工徑 A	F	D	L	螺絲 Screw	扳手 Wrench	刀片 Insert
鎢鋼柄 (圖一) Carbide Shank (Fig-1)								
●	C12M-SVQCR/L11-18	18	11	12	150	M2.5x6.0x3.6	T8	VC1103
●	C16M-SVQCR/L11-22	22	12.5	16	150			
●	C16R-SVQCR/L11-22	22	12.5	16	200			
○	C20R-SVQCR/L11-25	25	14	20	200	M3.5x12.0x5.4-67	T15	VC1604
●	C25R-SVQCR/L16-32	32	17	25	200			
○	C32S-SVQCR/L16-37	37	20	32	250			
鎢鋼柄 + 水孔 (圖二) Carbide Shank With Coolant (Fig-2)								
●	E16M-SVQCR/L11-22	22	12.5	16	150	M2.5x6.0x3.6	T8	VC1103
●	E16R-SVQCR/L11-22	22	12.5	16	200			
○	E20R-SVQCR/L11-25	25	13	20	200			
○	E25R-SVQCR/L16-32	32	17	25	200	M3.5x11.4x5.7	T15	VC1604
合金鋼柄 (圖一) Alloy Steel (Fig-1)								
●	S12M-SVQCR/L11-18	18	11	12	150	M2.5x6.0x3.6	T8	VC1103
●	S16Q-SVQC/LR11-22	22	12.5	16	180			
●	S20R-SVQCR/L11-25	25	14	20	200			
高硬度柄 (Y:圖二、Z:圖一) High Hardness Steel With Coolant (Y:Fig-2、Z:Fig-1)								
●	Y40T-SVQCR/L16-47	47	25.5	25	300	M3.5x11.4x5.7	T15	VC1604
●	Z25R-SVQCR/L16-32	32	17	25	200			

Zy 內徑車刀 Boring Bars

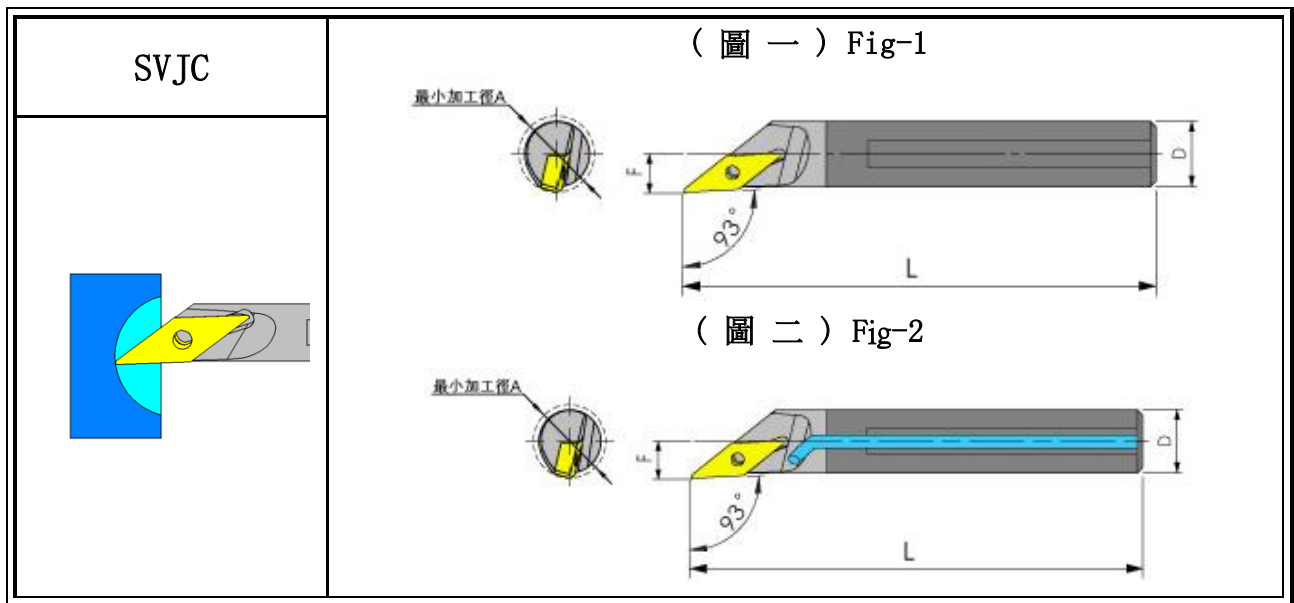

Stock	型號 Model No.	最小加工徑 A	F	D	L	螺絲 Screw	板手 Wrench	刀片 Insert
鎢鋼柄 (圖一) Carbide Shank (Fig-1)								
●	C06J-SVJCR/L08-085	8.5	3.25	6	110	M2x5.0x2.6	T6	VC0802
●	C08K-SVJCR/L08-10	10	5	8	125			
●	C10M-SVJCR/L08-12	12	6	10	150			
●	C12M-SVJCR/L08-14	14	7	12	150			
●	C10M-SVJCR/L11-12	12	6	10	150	M2.5x6.0x3.6	T8	VC1103
●	C12M-SVJCR/L11-14	14	7	12	150			
●	C12Q-SVJCR/L11-14	14	7	12	180			
●	C16M-SVJCR/L11-18	18	9	16	150			
●	C16R-SVJCR/L11-18	18	9	16	200			
●	C20R-SVJCR/L11-22	22	11	20	200			
●	C20S-SVJCR/L11-22	22	11	20	250	M3.5x12.0x5.4-67	T15	VC1604
●	C16M-SVJCR/L16-18	18	9	16	150			
●	C16R-SVJCR/L16-18	18	9	16	200			
○	C20R-SVJCR/L16-23	23	11.5	20	200			
○	C25R-SVJCR/L16-28	28	14	25	200			
○	C32S-SVJCR/L16-35	35	17.5	32	250			
鎢鋼柄 + 水孔 (圖二) Carbide Shank With Coolant (Fig-2)								
●	E06J-SVJCR/L08-085	8.5	3.25	6	110	M2x5.0x2.6	T6	VC0802

●	E08K-SVJCR/L08-10	10	5	8	125			
●	E10M-SVJCR/L08-12	12	6	10	150			
○	E12M-SVJCR/L08-14	14	7	12	150			
●	E10M-SVJCR/L11-12	12	6	10	150	M2. 5x6. 0x3. 6	T8	VC1103
●	E12M-SVJCR/L11-14	14	7	12	150			
●	E12Q-SVJCR/L11-14	14	7	12	180			
●	E16M-SVJCR/L11-18	18	9	16	150			
●	E16R-SVJCR/L11-18	18	9	16	200			
●	E20R-SVJCR/L11-22	22	11	20	200			
●	E20S-SVJCR/L11-22	22	11	20	250			
●	E16M-SVJCR/L16-18	18	9	16	150	M3. 5x12. 0x5. 4	T15	VC1604
○	E16R-SVJCR/L16-18	18	9	16	200			
○	E20R-SVJCR/L16-23	23	11.5	20	200			
○	E25R-SVJCR/L16-28	28	14	25	200			
合金鋼柄 (圖一) Alloy Steel (Fig-1)								
●	S08K-SVJCR/L08-10	10	5	8	125	M2x5. 0x2. 6	T6	VC0802
●	S10K-SVJCR/L08-12	12	6	10	125			
●	S12M-SVJCR/L08-14	14	7	12	150			
●	S10K-SVJCR/L11-12	12	6	10	125	M2. 5x6. 0x3. 6	T8	VC1103
●	S12M-SVJCR/L11-14	14	7	12	150			
●	S16Q-SVJCR/L11-18	18	9	16	180			
●	S20R-SVJCR/L11-22	22	11	20	200			
●	S16Q-SVJCR/L16-18	18	9	16	180	M3. 5x12. 0x5. 4	T15	VC1604
●	S20R-SVJCR/L11-23	23	11.5	20	200			
○	S25R-SVJCR/L16-32	32	14	25	200			
高硬度柄 (Y:圖二、Z:圖一) High Hardness Steel With Coolant (Y:Fig-2、Z:Fig-1)								
●	Y10M-SVJCR/L08-12	12	6	10	150	M2x5. 0x2. 6	T6	VC0802
●	Y12M-SVJCR/L08-14	14	7	12	150			
●	Z08H-SVJCR/L08-10	10	5	8	125			
●	Y10K-SVJCR/L11-12	12	6	10	125	M2. 5x6. 0x3. 6	T8	VC1103
●	Y12M-SVJCR/L11-14	14	7	12	150			
●	Y16Q-SVJCR/L11-18	18	9	16	180			
●	Y20R-SVJCR/L11-22	22	11	20	200			
○	Z16Q-SVJCR/L11-18	18	9	16	180			
○	Z20R-SVJCR/L11-22	22	11	20	200			
●	Y16N-SVJCR/L16-18	18	9	16	160			
○	Y20R-SVJCR/L16-23	23	11.5	20	200			
○	Z16N-SVJCR/L16-18	18	9	16	160			
●	Z20R-SVJCR/L16-23	23	11.5	20	200			

Zy 內徑車刀 Boring Bars

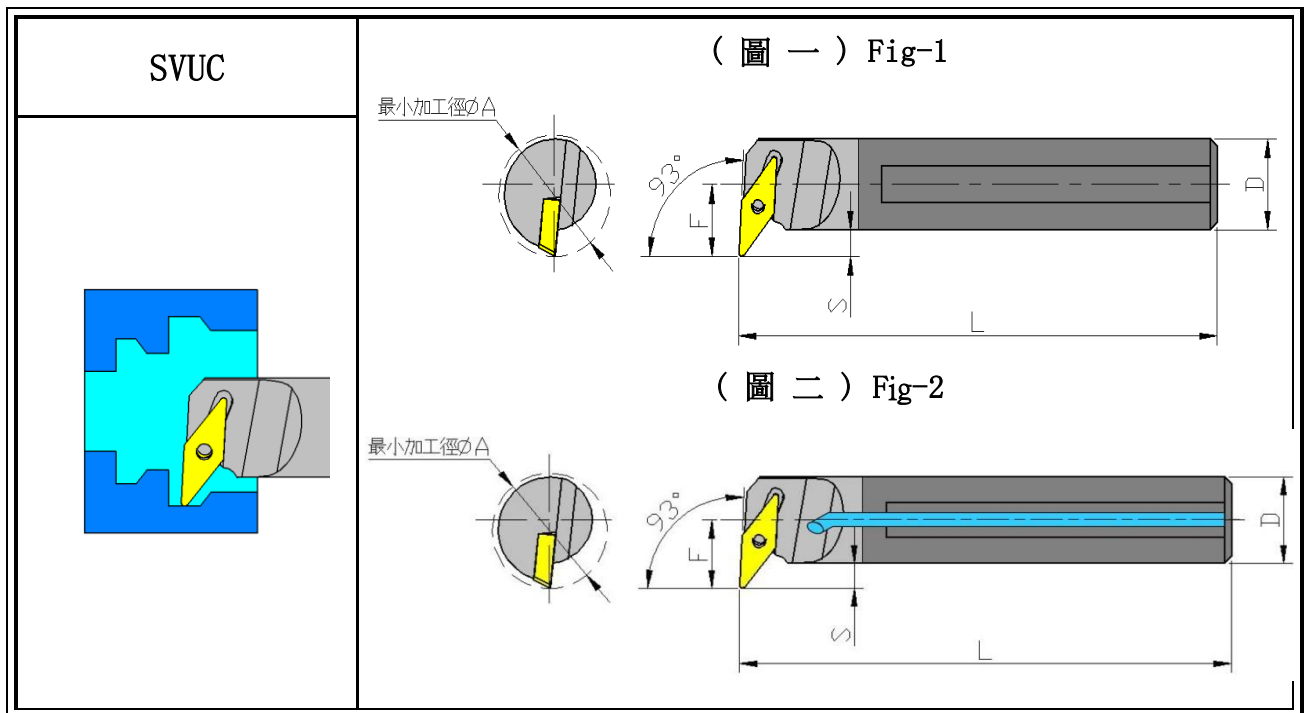

Stock	型號 Model No.	最小加工徑 A	F	D	L	S	螺絲 Screw	扳手 Wrench	刀片 Insert
錫鋼柄 (圖一) Carbide Shank (Fig-1)									
●	C10M-SVUCR/L07-15	15	8.5	10	150	3.5	M2x5.0x2.6	T6	VC0702
●	C12M-SVUCR/L07-15	15	8.5	12	150	2.5			
●	C12M-SVUCR/L08-16	16	9.5	12	150	3.5	M2x5.0x2.6	T6	VC0802
●	C12Q-SVUCR/L08-16	16	9.5	12	180	3.5			
●	C14M-SVUCR/L08-19	19	11	14	150	4			
●	C16M-SVUCR/L11-22	22	12.5	16	180	4.5	M2.5x6.0x3.6	T8	VC1103
●	C16R-SVUCR/L11-22	22	12.5	16	200	4.5			
●	C20R-SVUCR/L11-27	27	15	20	200	5			
○	C20S-SVUCR/L11-27	27	15	20	250	5			
●	C25R-SVUCR/L11-31	35	20	25	200	7.5			
○	C20R-SVUCR/L16-31	31	19	20	200	9	M3.5x12.0x5.4	T15	VC1604
○	C20S-SVUCR/L16-31	31	19	20	250	9			
○	C25R-SVUCR/L16-33	33	18	25	200	5.5			
○	C25S-SVUCR/L16-33	33	18	25	250	5.5			
○	C25R-SVUCR/L16-35	35	20	25	200	7.5			
○	C25S-SVUCR/L16-35	35	20	25	250	7.5			

○	C32S-SVUCR/L16-40	40	22	32	250	6			
鎢鋼柄 + 水孔 (圖二) Carbide Shank With Coolant (Fig-2)									
●	E16R-SVUCR/L11-22	22	12.5	16	200	4.5	M2.5x6.0x3.6	T8	VC1103
●	E20R-SVUCR/L11-27	27	15	20	200	5			
○	E25R-SVUCR/L11-30	30	17	25	250	4.5			
○	E20R-SVUCR/L16-31	31	19	20	200	9	M3.5x12.0x5.4	T15	VC1604
○	E25R-SVUCR/L16-33	33	18	25	200	5.5			
○	E25S-SVUCR/L16-33	33	18	25	250	5.5			
○	E25R-SVUCR/L16-35	35	20	25	200	7.5			
○	E25S-SVUCR/L16-35	35	20	25	250	7.5			
○	E32S-SVUCR/L16-40	40	22	32	250	6			
合金鋼柄 (圖一) Alloy Steel (Fig-1)									
●	S12M-SVUCR/L07-15	15	8.5	12	150	2.5	M2x5.0x2.6	T6	VC0702
●	S12M-SVUCR/L08-16	16	9.5	12	150	3.5	M2x5.0x2.6	T6	VC0802
●	S16Q-SVUCR/L11-22	22	12.5	16	180	4.5	M2.5x6.0x3.6	T8	VC1103
●	S20R-SVUCR/L11-27	27	15	20	200	5			
○	S25R-SVUCR/L16-35	35	20	25	200	7.5	M3.5x12.0x5.4	T15	VC1604
高硬度柄 (Y:圖二、Z:圖一) High Hardness Steel With Coolant (Y:Fig-2、Z:Fig-1)									
●	Y12M-SVUCR/L07-15	15	8.5	12	150	2.5	M2x5.0x2.6	T6	VC0702
●	Y12M-SVUCR/L08-16	16	9.5	12	150	3.5	M2x5.0x2.6	T6	VC0802
●	Y16N-SVUCR/L11-22	22	12.5	16	160	4.5	M2.5x6.0x3.6	T8	VC1103
●	Y20R-SVUCR/L11-27	27	15	20	200	5			
●	Z16Q-SVUCR/L11-22	22	13	16	180	4.5			
●	Z20R-SVUCR/L11-27	27	15	20	200	5			
○	Z25R-SVUCR/L11-31	31	17	25	250	4.5			
●	Y40T-SVUCR/L16-48	48	27	40	300	7	M3.5x12.0x5.4	T15	VC1604
●	Z25R-SVUCR/L16-33	33	18	25	200	5.5			

●:庫存 In Stock ○:非標準庫存(請確認交貨期) Non-standard Stock

Zy 內徑車刀 Boring Bars

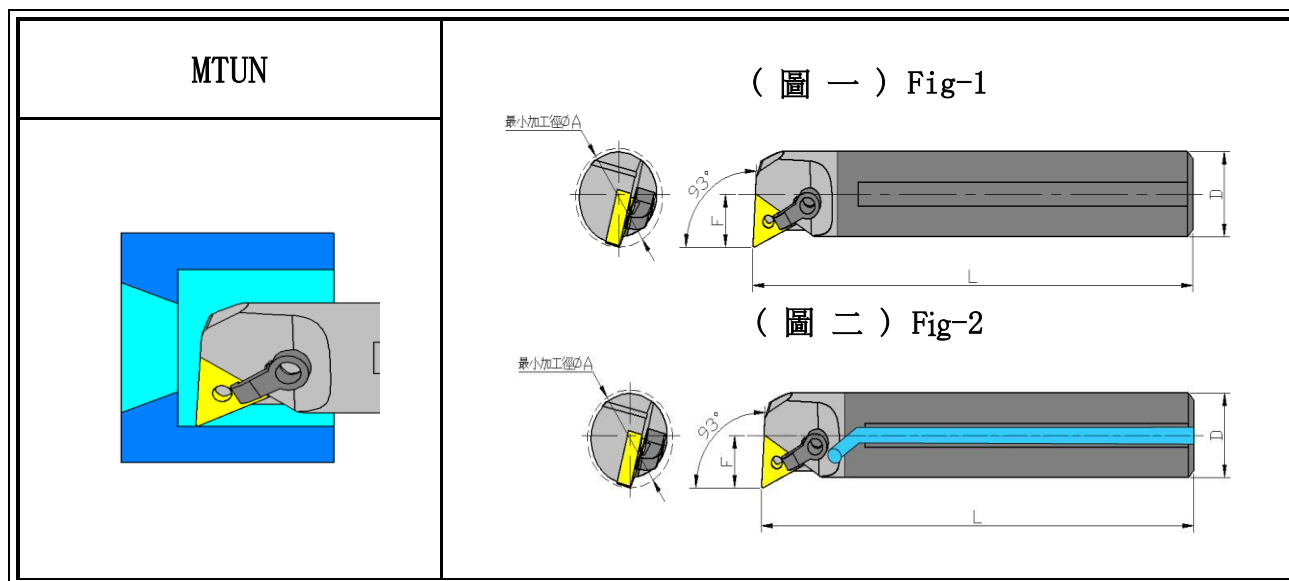

Stock	型號 Model No.	最小加工徑 A	F	D	L	墊片 Shim	雙頭螺絲 Clamp Screw	壓板 Clamp	偏心螺絲 Shim Screw	板手 Wrench
錫鋼柄 (圖一) Carbide Shank (Fig-1)										
●	C16M-MTUNR/L16-22A	22	11.5	16	150		MS518	CP50-12	LCS-510	P2.0
●	C16R-MTUNR/L16-22A	22	11.5	16	200					P2.5
●	C20R-MTUNR/L16-25A	25	13	20	200	-	MS520	CP50-12	LCS-510	P2.0
●	C20S-MTUNR/L16-25A	25	13	20	250					P2.5
●	C25R-MTUNR/L16-32A	32	17	25	200	-	MS620	CP50-22	LCS-510	P2.0
●	C25S-MTUNR/L16-32A	32	17	25	250					P3.0
○	C32S-MTUNR/L16-40A	40	20	32	250	TMS322	MS625	CP50-22	LCS-513	P2.0
○	C40S-MTUNR/L16-50A	50	26	40	250					P3.0
○	C50S-MTUNR/L16-60A	60	31	50	250					
錫鋼柄 + 水孔 (圖二) Carbide Shank With Coolant (Fig-2)										
●	E20R-MTUNR/L16-25A	25	13	20	200	-	MS520	CP50-12	LCS-510	P2.0
●	E20S-MTUNR/L16-25A	25	13	20	250					P2.5
●	E25R-MTUNR/L16-32A	32	17	25	200	-	MS620	CP50-22	LCS-510	P2.0
●	E25S-MTUNR/L16-32A	32	17	25	250					P3.0
○	E32S-MTUNR/L16-40A	40	20	32	250	TMS322	MS625	CP50-22	LCS-513	P2.0 P3.0
合金鋼柄 (圖一) Alloy Steel (Fig-1)										
●	S20R-MTUNR16-22A	22	13	20	200	-	GCS520	CP50-26	LCS-510	P3.0

○	S25R-MTUNR16-32A	32	17	25	200		GCS620	CP50-22	LCS-510	P3.0
高 硬 度 柄 (Y : 圖 二 、 Z : 圖 一) High Hardness Steel With Coolant (Y : Fig-2 、 Z : Fig-1)										
○	Y16N-MTUNR/L16-22A	22	11.5	16	160	-	MS518	CP50-12	LCS-510	P2.0 P2.5
●	Y16Q-MTUNR/L16-22A	22	11.5	16	180					
○	Z16N-MTUNR/L16-22A	22	11.5	16	160					
●	Z16Q-MTUNR/L16-22A	22	11.5	16	180					
●	Y20R-MTUNR/L16-25A	25	13	20	200	-	MS520	CP50-12	LCS-510	P2.0 P2.5
●	Z20R-MTUNR/L16-25A	25	13	20	250					
○	Y25R-MTUNR/L16-32A	32	17	25	200	-	MS620	CP50-22	LCS-510	P2.0 P3.0
○	Y25S-MTUNR/L16-32A	32	17	25	250					
●	Z25R-MTUNR/L16-32A	32	17	25	200					
●	Z25S-MTUNR/L16-32A	32	17	25	250					
●	Y40T-MTUNR/L16-47A	47	26	40	300					
●	Y50U-MTUNR/L16-57A	57	31	50	350					
						TMS322	MS625	CP50-22	LCS-513	

●:庫存 In Stock ○:非標準庫存(請確認交貨期) Non-standard Stock

刀片 Inserts:TN16

Zy 內徑車刀 Boring Bars

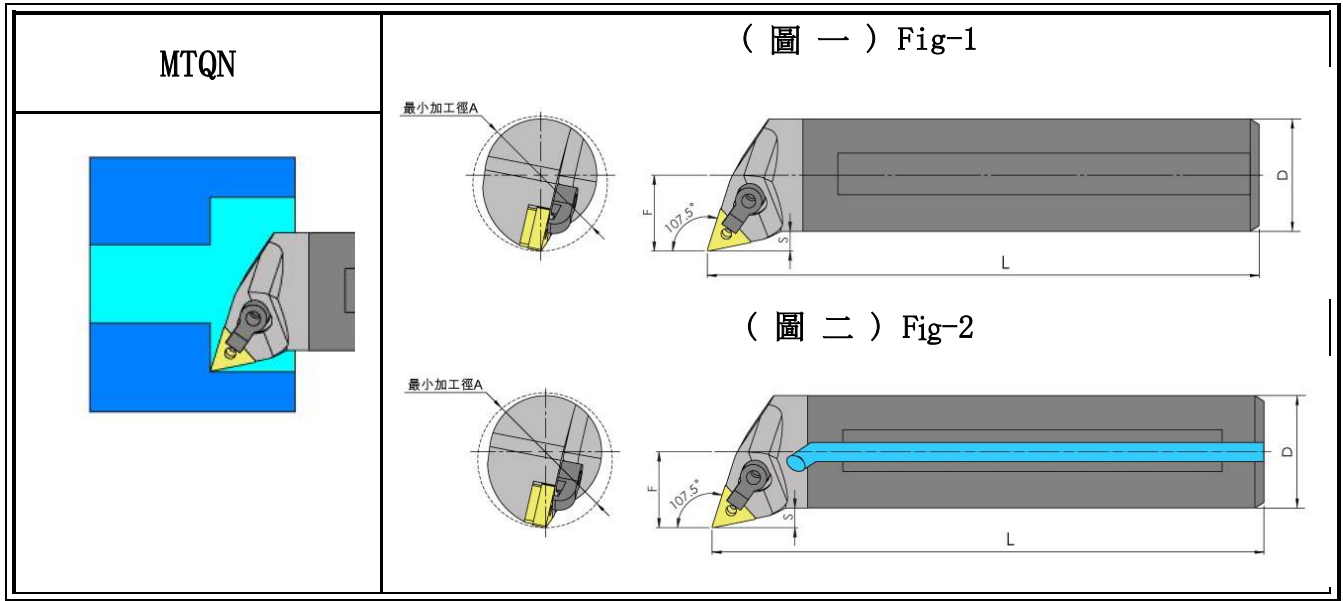

Stock	型號 Model No.	最小加工徑 A	F	D	L	墊片 Shim	雙頭螺絲 Clamp Screw	壓板 Clamp	偏心螺絲 Shim Screw	板手 Wrench
錫鋼柄 (圖一) Carbide Shank (Fig-1)										
○	C20R-MTQNR/L16-25	25	12.5	20	200	-	MS520	CP50-12	LCS510	L2.0 L2.5
○	C25R-MTQNR/L16-32	32	16	25	200	-				
○	C32S-MTQNR/L16-41	41	22.5	32	250	-				
○	C40T-MTQNR/L16-50	50	26.5	40	300	-				
高硬度柄 (Y:圖二、Z:圖一) High Hardness Steel With Coolant (Y:Fig-2、Z:Fig-1)										
●	Y50T-MTQNR/L16-57	57	31	50	300	TMS322	MS625	CP50-22	LCS513	L2.0 L3.0

●:庫存 In Stock ○:非標準庫存(請確認交貨期) Non-standard Stock

刀片 Inserts:TN1604

Zy 內徑車刀 Boring Bars

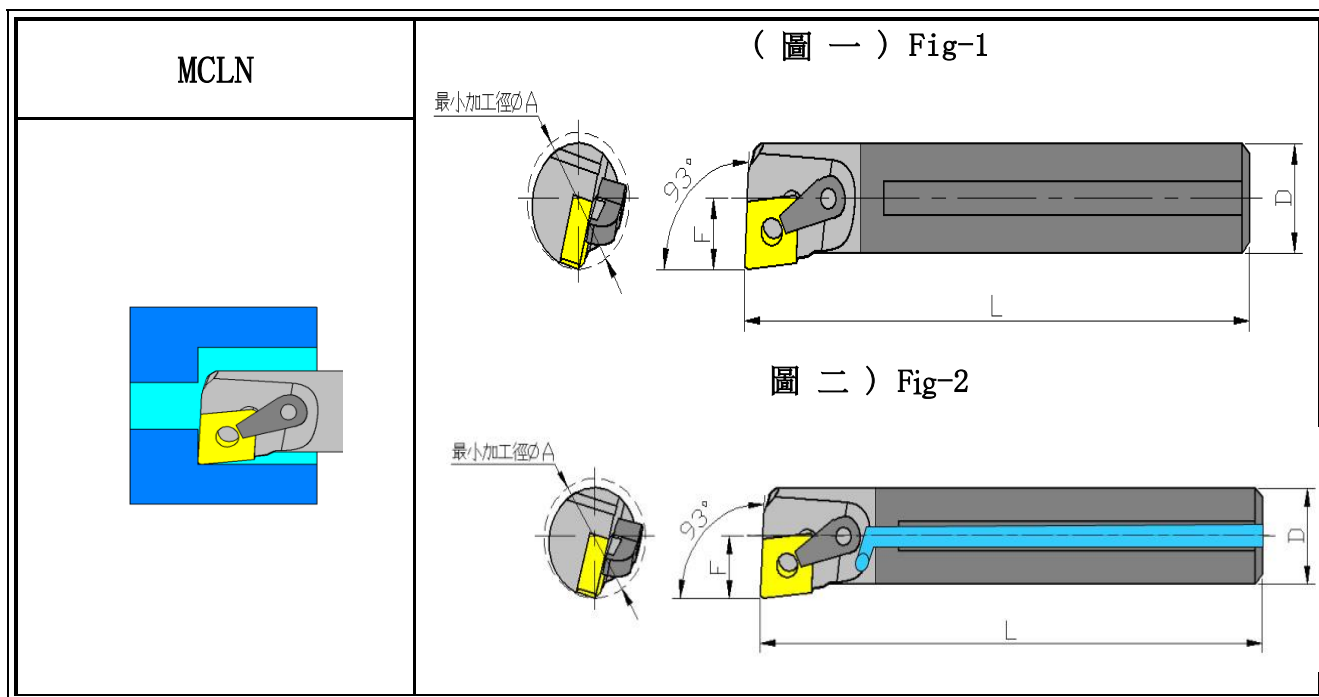

Stock	型號 Model No.	最小加工徑 A	F	D	L	墊片 Shim	雙頭螺絲 Clamp Screw	壓板 Clamp	偏心螺絲 Shim Screw	板手 Wrench
鎢鋼柄 (圖一) Carbide Shank (Fig-1)										
●	C20R-MCLNR/L12-25	25	13	20	200	-	MS520	CP50-12	LCS-511	L2.5
●	C20S-MCLNR/L12-25	25	13	20	250					
●	C25R-MCLNR/L12-32	32	15	25	200	-	MS625	CP50-22	LCS-511	L2.5
○	C25S-MCLNR/L12-32	32	15	25	250					
○	C32S-MCLNR/L12-40	40	20	32	250	CMS432	MS625	CP50-22	LCS-617	L3.0
○	C40S-MCLNR/L12-50	50	25	40	250					
○	C50T-MCLNR/L12-60	60	30	50	300					
鎢鋼柄 + 水孔 (圖二) Carbide Shank With Coolant (Fig-2)										
●	E20R-MCLNR/L12-25	25	13	20	200	-	MS520	CP50-12	LCS-511	L2.5
●	E20S-MCLNR/L12-25	25	13	20	250					
●	E25R-MCLNR/L12-32	32	15	25	200	-	MS625	CP50-22	LCS-511	L2.5
○	E25S-MCLNR/L12-32	32	15	25	250					
○	E32S-MCLNR/L12-40	40	20	32	250	CMS432	MS625	CP50-22	LCS-617	L3.0

●:庫存 In Stock ○:非標準庫存(請確認交貨期) Non-standard Stock

刀片 Inserts:CN1204

Zy 內徑車刀 Boring Bars

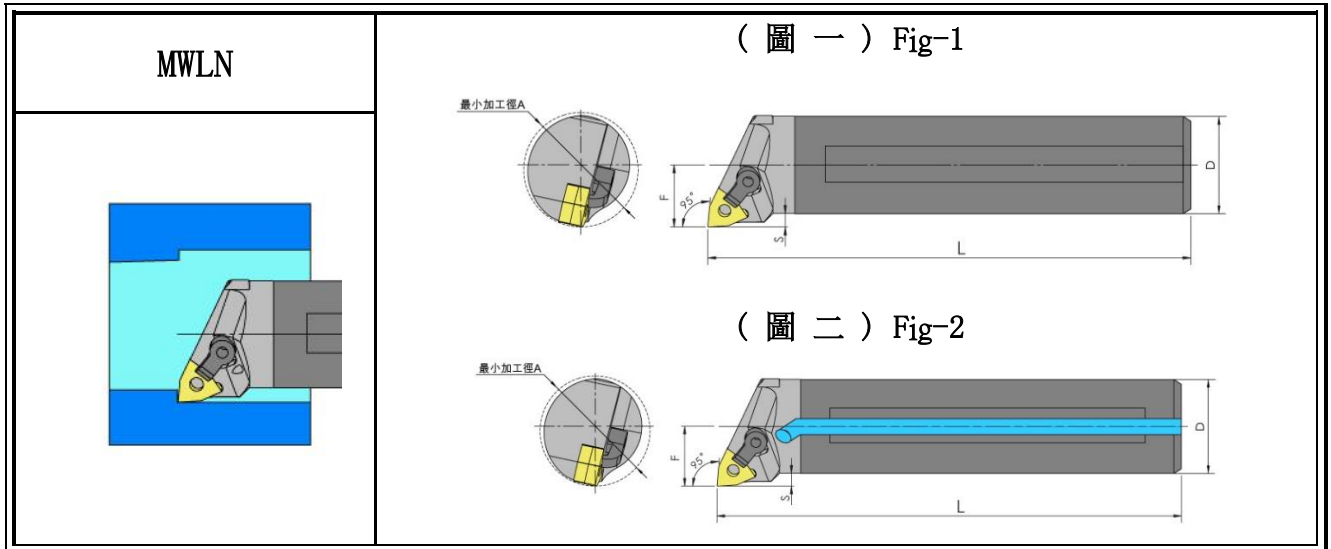

Stock	型號 Model No.	最小加工徑	F	D	L	墊片 Shim	雙頭螺絲 Clamp Screw	壓板 Clamp	偏心螺絲 Shim Screw	板手 Wrench		
鎢鋼柄 (圖一) Carbide Shank (Fig-1)												
●	C20R-MWLN/L08-25	25	13	20	200	-	MS520	CP50-12	LCS-511	P2.0 P2.5		
○	C25R-MWLN/L08-32	32	17	25	200	-	MS625	CP50-22	LCS-511	P2.5 P3.0		
鎢鋼柄 + 水孔 (圖二) Carbide Shank With Coolant (Fig-2)												
○	E20R-MWLN/L08-25	25	13	20	200	-	MS520	CP50-12	LCS-511	P2.0 P2.5		
○	E25R-MWLN/L08-32	32	17	25	200	-	MS625	CP50-22	LCS-511	P2.5 P3.0		
合金鋼柄 (圖一) Alloy Steel (Fig-1)												
●	S20R-MWLN/L08-25	25	13	20	200	-	MS520	CP50-12	LCS-511	P2.0 P2.5		
高硬度柄 (Y:圖二、Z:圖一) High Hardness Steel With Coolant (Y:Fig-2、Z:Fig-1)												
●	Y20R-MWLN/L08-25	25	13	20	200	-	MS520	CP50-12	LCS-511	P2.0 P2.5		
●	Y25R-MWLN/L08-32	32	17	25	200	-	MS625	CP50-22	LCS-511	P2.5 P3.0		
○	Y32S-MWLN/L08-40	40	20	32	250	WMS432			MS625		CP50-22	LCS-617
●	Y40T-MWLN/L08-47	47	25.5	40	300							
●	Y50U-MWLN/L08-57	57	30.5	50	350							

●:庫存 In Stock ○:非標準庫存(請確認交貨期) Non-standard Stock

刀片 Inserts:WN0804