

# 鎢鋼抗震刀桿

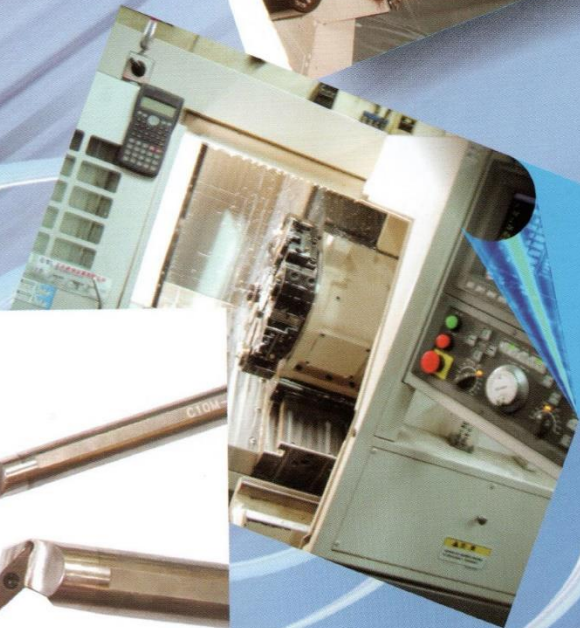

Tungsten Carbide Shank

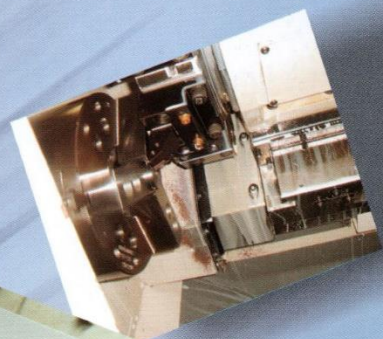



# CUTTING TOOLS

## 目次

A 功能性系列 Adjustable Series	.....	A1-A10
B 內徑車刀 Boring Bars	.....	B1-B49
C 內徑車刀套筒 Sleeve	.....	C1-C5
D 外徑出水車刀 Tool Holder With Coolant	.....	D1-D25
E 外徑車刀 Turning Tools Holder	.....	E1-E29
F 切槽刀具系列 Grooving Tool Holders	.....	F1-F19
✓ 內徑切槽、內徑端面切槽		
✓ 外徑切槽、外徑端面切槽		
✓ 模組式刀頭		
G 牙刀系列 Threading Tool Holders	.....	G1-G8
✓ 內徑牙刀		
✓ 外徑牙刀		
✓ 模組式刀頭牙刀		
H 模組化 SCK 內徑車刀系列 Modular Chang Boring Bars		H1-H39
I 阻尼刀桿 Damping Anti-Vibration Boring Bar	.....	I1-I10
J 搪刀系列 Boring Tools Series	.....	J1-J7
K 銑刀系列 End Mill Series	.....	K1-K15
✓ 鎖牙式		
✓ 一體式		
L C 型快鑽 C Type Speed Drills	.....	L1-L4
M 扭力板手 Torque Screwdriver	.....	M1-M2
N 內圓球面與內圓端面應用	.....	N1

# 功能性系列

## 增加你的工作效率

- 外徑中心車刀架
- CKC-中心找尋規
- ADC-模組化外徑端內孔中心刀架
- ADC-內徑套筒
- ADC-外徑車刀架

**中陽切削工具有限公司**

**ZHONG YANG CUTTING TOOLS CO., LTD**

**41141 台中市太平區東平路 96 號**

**TEL.: 04-22760339**

**FAX : 04-22764812**

**SKYPE & LINE ID : zy-cutting**

**E-mail : zycutting@gmail.com**

**www.zy-cutting.com.tw**



2024.03 N01

# 模組化外徑端內徑中心.刀架



刀架



套筒



中心鑽



可以搭配小徑車刀來使用

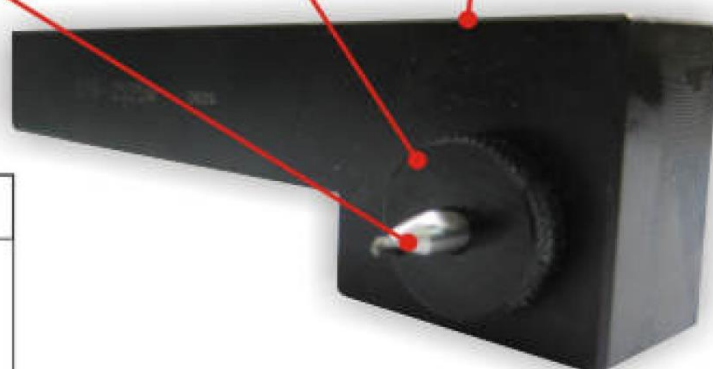

組合圖



## 搭配產品

SH-0416-31	SH-0516-31	SH-0616-31	SH-0716-31	SH-0816-33	SH-1016-33	SH-1216-33

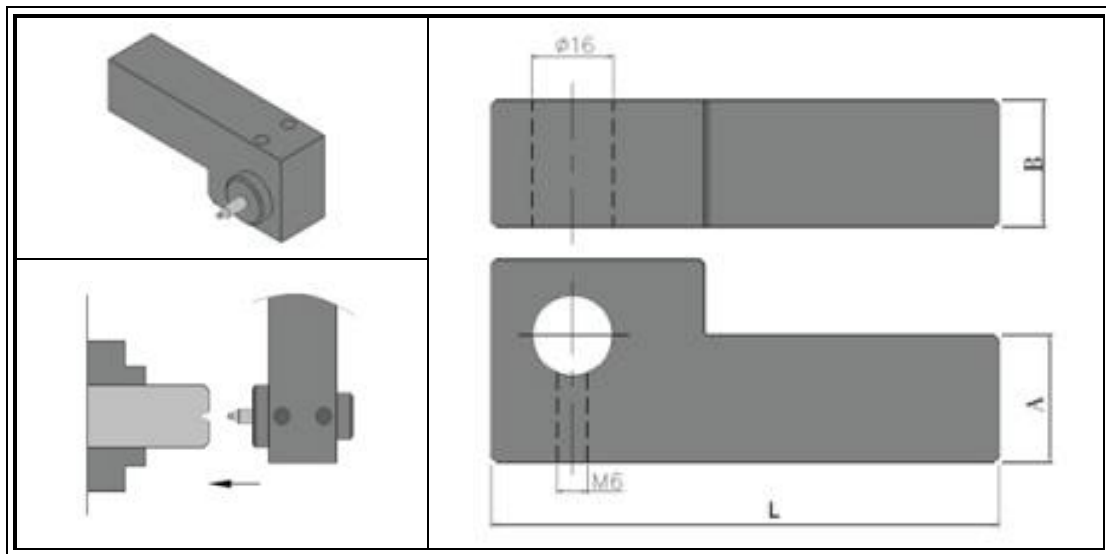

# Zy 外徑中心車刀架 External Center Tool Holder





stock	型號 Model No.	A	B	F	L	 螺絲 Screw	 板手 Wrench
●	D16-2020K	20	20	16	125	SETM6x8L	L3.0
●	D16-2525M	25	25	16	150		

●:庫存 In Stock    ○:非標準庫存(請確認交貨期) Non-standard Stock

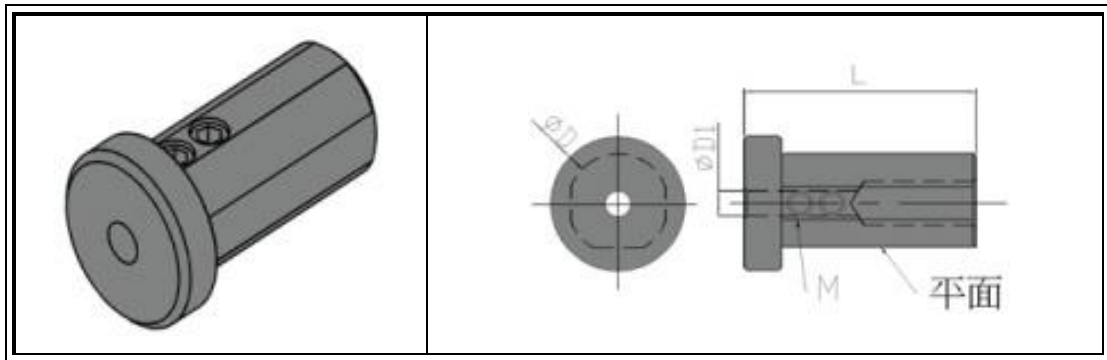
# Zy 外徑中心車刀架套筒 External Center Sleeve



stock	型號 Model No.	D	D1	H	L	 螺絲 Screw	 板手 Wrench
●	SH-0416-31	16	4	15	31	SETM4x4L	P2.0
●	SH-0516-31	16	5	15	31	SETM5x5.5L	P2.5
●	SH-0616-31	16	6	15	31	SETM6x4L	P3.0
●	SH-0716-31	16	7	15	31	SETM5x4L	P2.5
●	SH-07716-31	16	7.7	15	31		
●	SH-0816-33	16	8	15	33	SETM6x4L	P3.0
●	SH-1016-33	16	10	15	33		
●	SH-1216-33	16	12	15	33		

●:庫存 In Stock    ○:非標準庫存(請確認交貨期) Non-standard Stock



# 獨家開發！

## 多種簡易的工具互相搭配，

CKC-中心找尋規

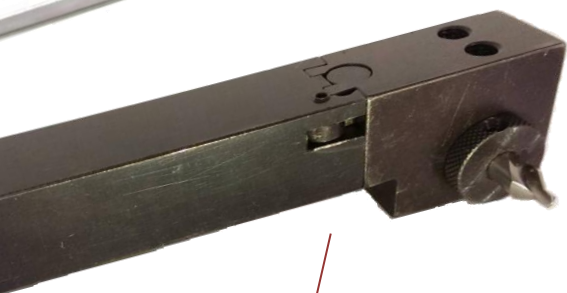

ADC-可調中心高模組化外徑端內孔中心刀架



ADC-可調中心內徑套筒



ADC-可調刀尖高外徑車刀架





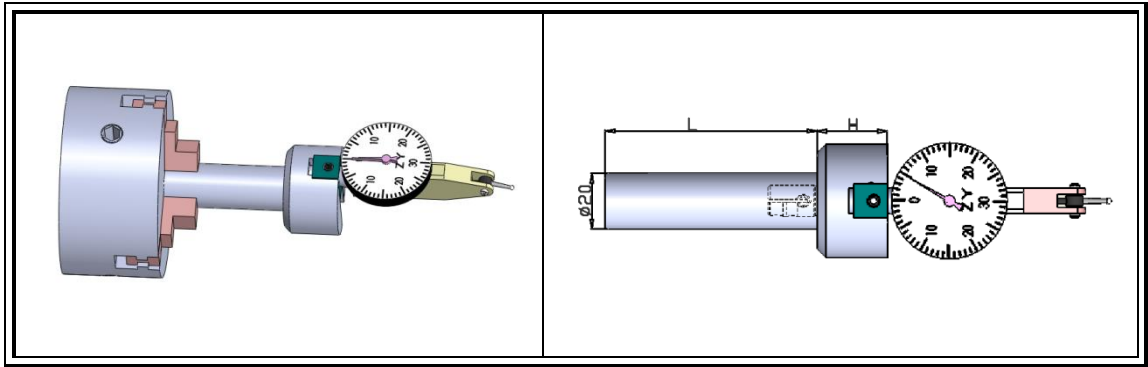

# 高效率，低成本！

## 可調式工具系列

# Zy CKC- 中心找尋規



stock	型號 Model No.	H	L	 滑動螺絲 Sliding screw	 固定螺絲 Lock screw	 刀桿螺絲 Holder screw	 板手 Wrench
●	CKC20-200L-SW	25	20	SETM4x4L	SETM4x6L	SETM5x6L	L2.0 L3.0

●:庫存 In Stock    ○:非標準庫存(請確認交貨期) Non-standard Stock

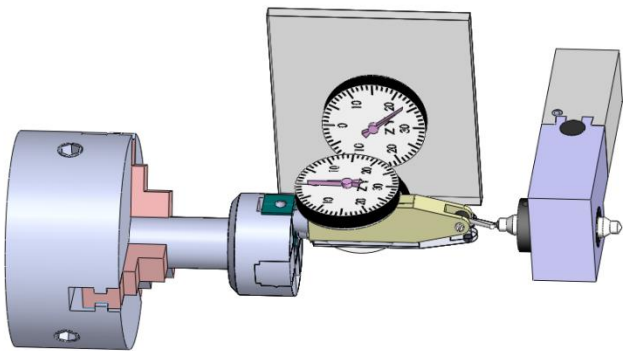

## 🌀 特色與功能：

1. 查找主軸與刀塔內孔的同心度。
2. 量測範圍大。
3. 檢查刀塔在 Z 軸向移動時，A 點與 B 點(特定点)有無同心。
4. 檢查 Z 軸向移動時的平行度。
5. 可當量測工件量具組件。





# CKC - 中心找尋規使用步驟

方便查找

主軸與刀塔內孔的同心度

## 使用步驟一.

將 $\phi 20$ 柄桿身固定於主軸上。  
並將橫桿錶置於孔內，鎖上“錶”螺絲。

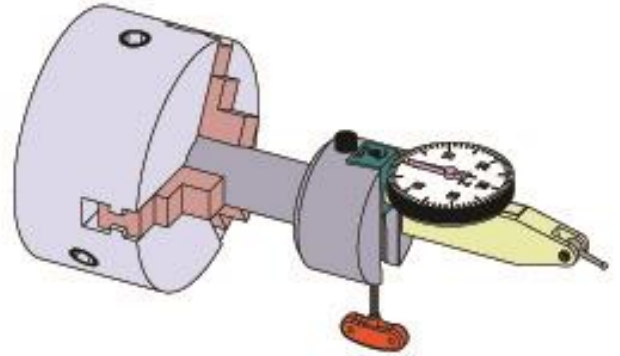

## 使用步驟二.

逆轉微鬆開LOCK螺絲

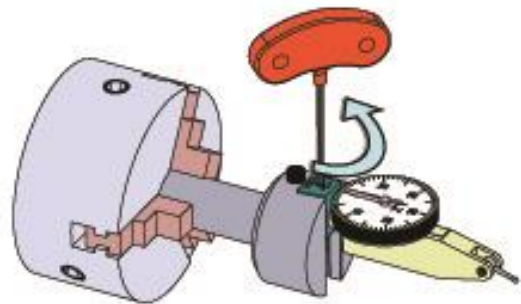

## 使用步驟三.

正轉 轉動微調螺桿可讓錶前進、後退移動，  
逆轉 並到達適當位置。

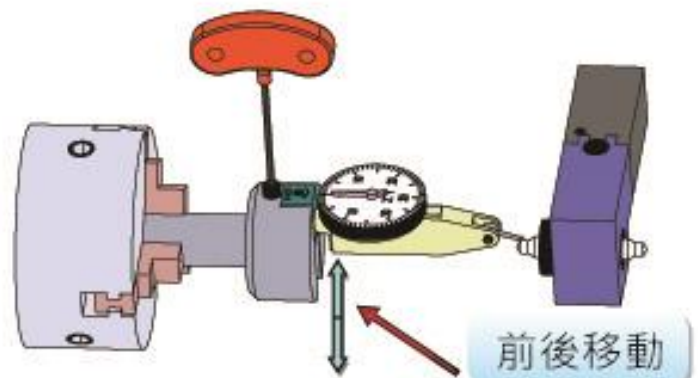

## 使用步驟四.

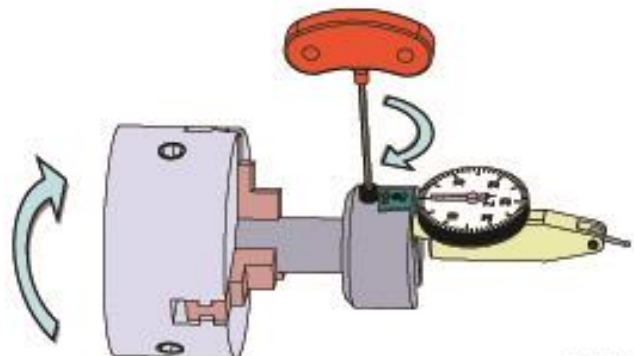

確認位置後鎖緊LOCK螺絲，  
用手轉動主軸，讀取錶面指示，  
就可以找出刀塔內孔中心與主軸  
的同心。

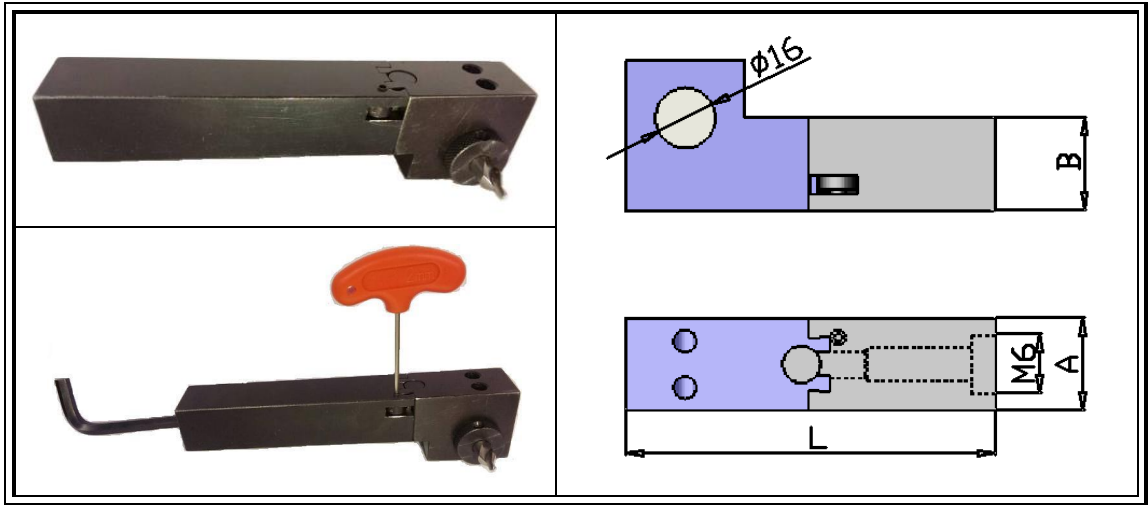

2022.03.No1

# Zy ADC-可調中心高 模組化外徑端內孔中心刀架



stock	型號 Model No.	A	B	F	L	 螺絲 Screw	 板手 Wrench
●	ADCD16-2020	20	20	16	145	SETM8x6L	L4.0
●	ADCD16-2525	25	25	16	145	SETM8x6L	L4.0
●	ADCD16-3232	32	32	16	145	SETM8x6L	L4.0

●:庫存 In Stock    ○:非標準庫存(請確認交貨期) Non-standard Stock



▲可藉由轉動調整螺絲，進行微調，讓刀具可以上下移動，迅速使主軸與刀具同軸心。



▲ 鬆開前

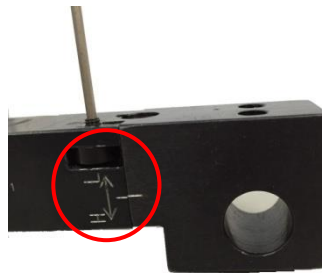

▲ 鬆開後，可上也可下！



# Zy ADC-可調中心高 內徑套筒

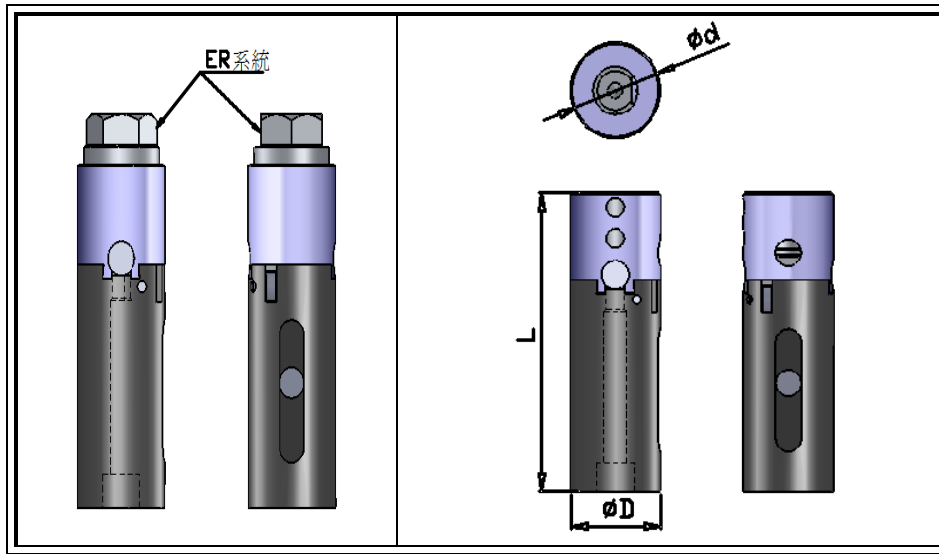

stock	型號 Model No.	$\phi D$	$\phi d$	L	螺絲 Screw	板手 Wrench
●	ADC32-D16	32	16	125	SETM8x6L	L4.0
●	ADC32-D20	32	20	125	SETM8x6L	L4.0
●	ADC40-D16	40	16	125	SETM8x6L	L4.0
●	ADC40-D20	40	20	125	SETM8x6L	L4.0
●	ADC32-ER16	32	ER16	150	-	L4.0
●	ADC32-ER20	32	ER20	150	-	L4.0
●	ADC40-ER16	40	ER16	150	-	L4.0
●	ADC40-ER20	40	ER20	150	-	L4.0

●:庫存 In Stock    ○:非標準庫存(請確認交貨期) Non-standard Stock



◀ 搭配 ER 系統，可夾持其他種類的刀具。

# Zy ADC-可調刀尖高 外徑車刀架

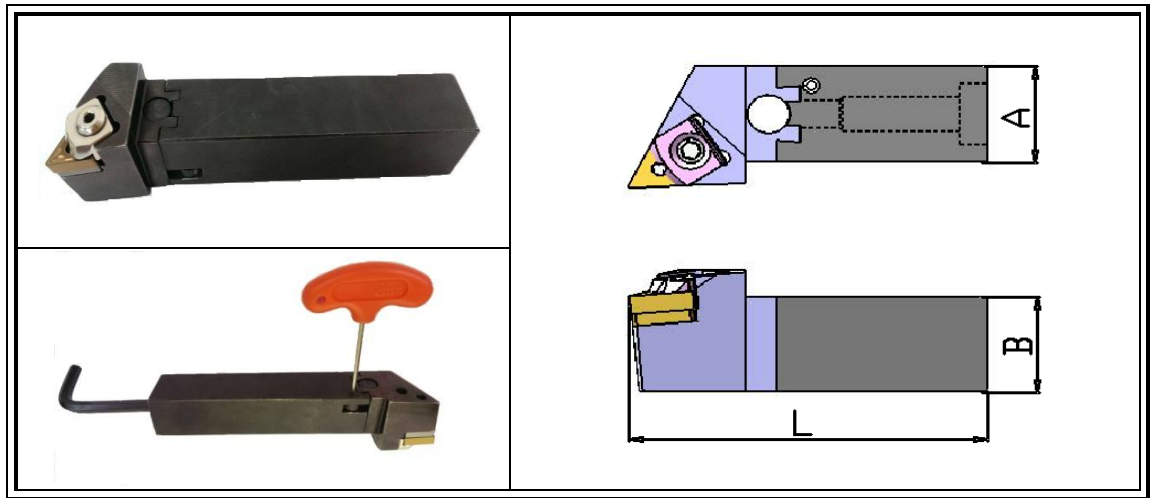

stock	型號 Model No.	A	B	L	 墊片 Shim	 中心柱 Shim Screw	 W型壓板組 Clamp	 螺絲 Screw	 板手 Wrench
●	ADCWTJNR-2525M-16	25	25	150	TMS322	GST-519-1	C-GTCT-1515 GVCW-621 LTW5103-21	SETM8x6L	L4.0

●:庫存 In Stock    ○:非標準庫存(請確認交貨期) Non-standard Stock



⊙ ADC-外徑車刀架可以解決：

1. 工件留芯。
2. 負角刀片因不同 R 角產生刀尖高度的問題。
3. 因刀尖高度不適當，造成車削不穩定的狀況。
4. 工時過長的問題。

不用再墊了! 不用再銑了!

# ADC-可調刀尖高車刀架使用步驟

解決了 **刀尖高度** 不適當造成的各種問題。

## 使用步驟一.

鬆開後拉螺絲(半圈)。

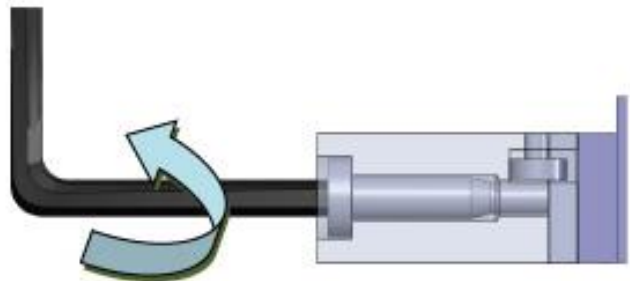

## 使用步驟二.

逆時針方向轉動調整螺絲到底，此時刀高最低。

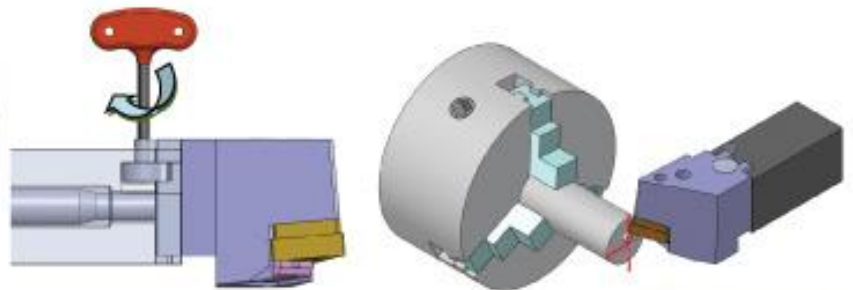

## 使用步驟三.

鎖緊後拉螺絲後，開始車削端面，並量取芯仔的尺寸(A)。

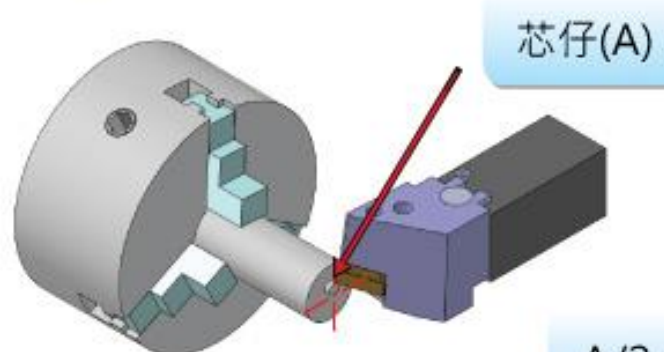

## 使用步驟四.

將錶架設於刀頭背面，鬆開後拉螺絲半圈，順時針轉動調整螺絲到A/2的數字。最後將後拉螺絲鎖緊，即完成步驟。

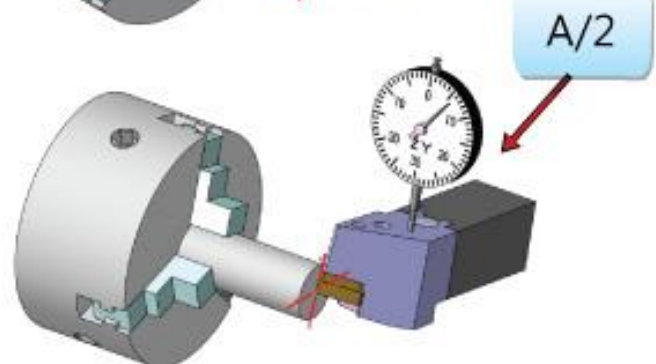

在鬆開調整螺絲前，請記得鬆開後拉螺絲！  
在車削之前，請記得鎖緊後拉螺絲！



# 內徑車刀系列刀桿

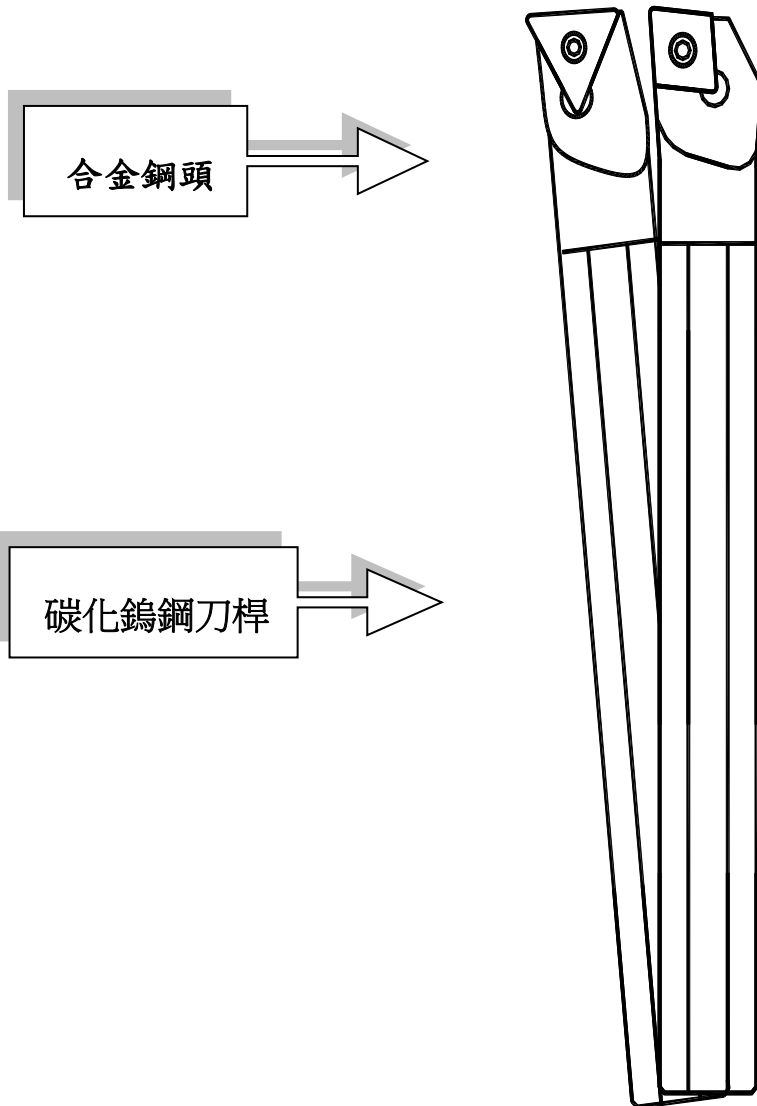

# 內圓車刀表示方法 Boring Bar Identification system

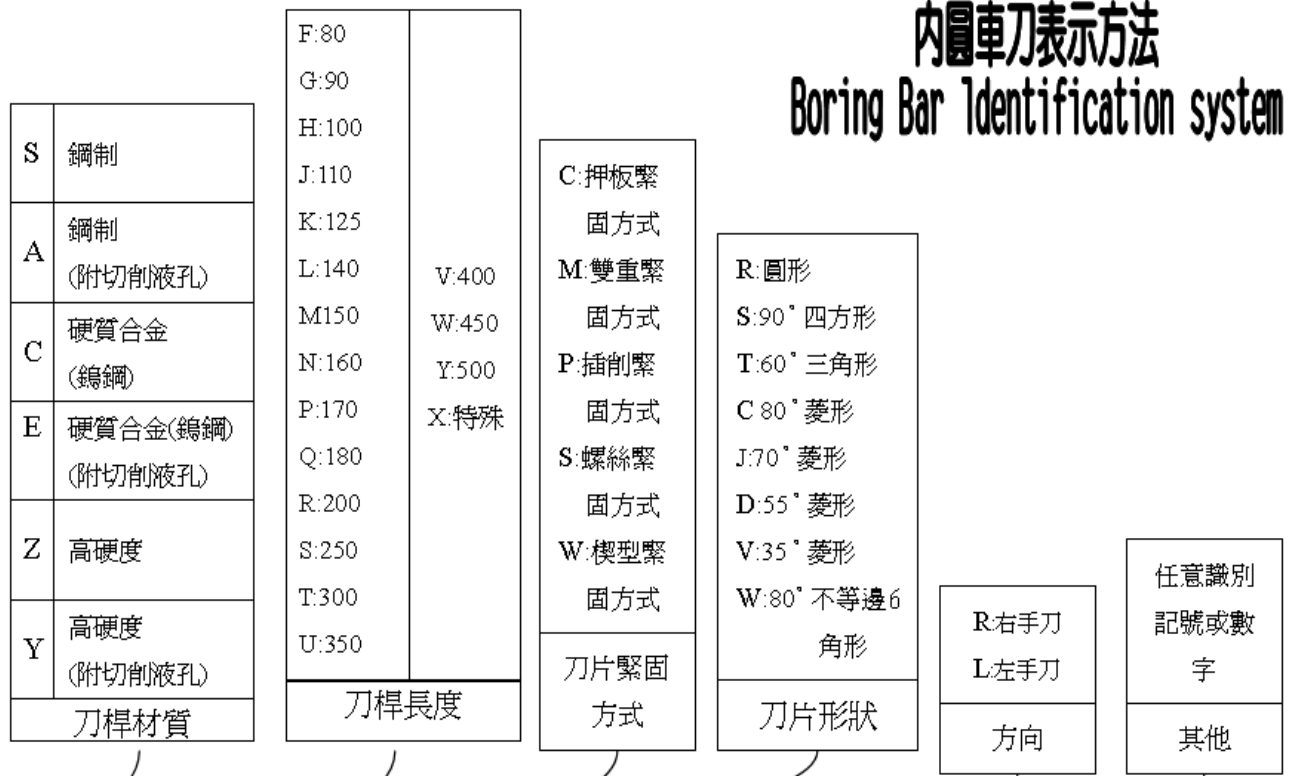

**S** **12** **M** - **S** **T** **L** **C** **R** **09** - **16**

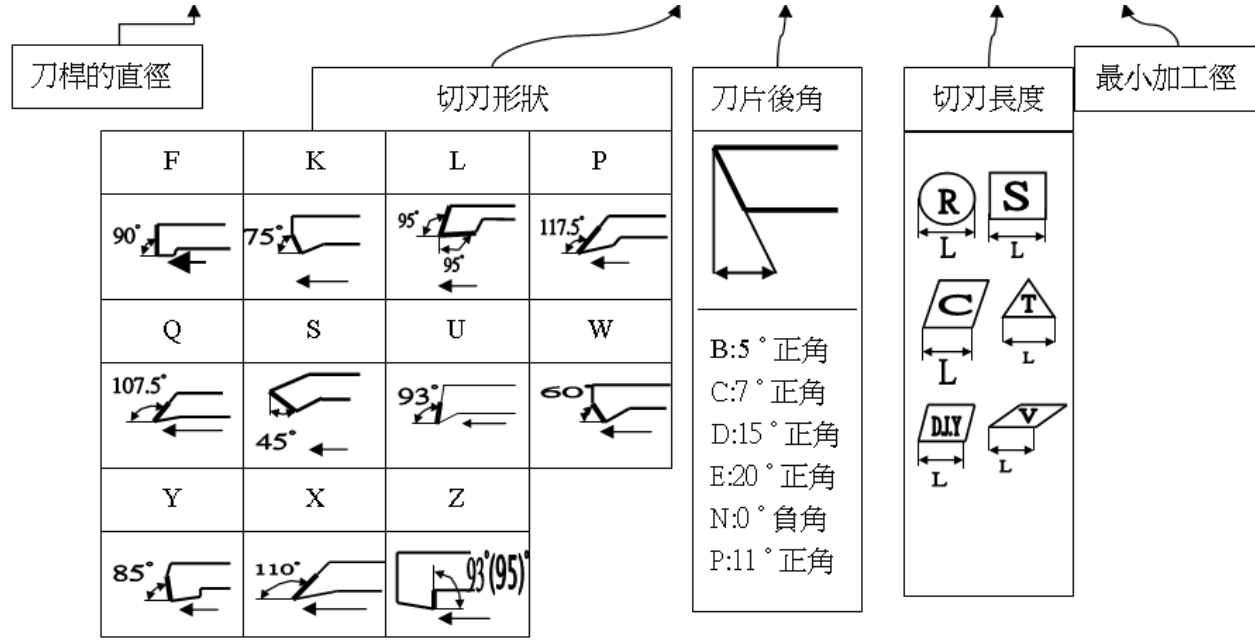

# Zy 微小徑內徑車刀 Mini Boring Bars

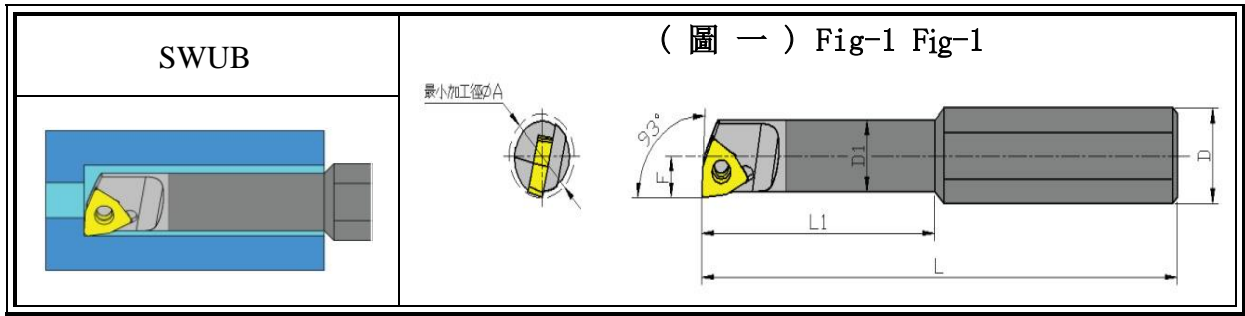

stock	型號 Model No.	最小加工徑 A	F	D1	D	L1	L	螺絲 Screw	扳手 Wrench	刀片 Insert
鎢鋼柄 (圖一) Carbide Shank (Fig-1)										
○	C0805K-SWUCR02-06-10L	6	3	5	8	10	125	M2x3.7x2.6-60	T6	WC0201
●	C0806K-SWUBR06-07-20L	7	3.5	6	8	20	125	M2x5.0x2.6	T6	WB0601
●	C0807K-SWUBR06-08-20L	8	4	7	8	20	125			
●	C0807K-SWUBR06-08-30L	8	4	7	8	20	125			
○	C1005M-SWUBR06-06-15L	6	3	5	10	15	150	M2x3.7x2.6-60	T6	WB0601
○	C1006M-SWUBR06-07-15L	7	3.5	6	10	15	150	M2x5.0x2.6		
○	C1007M-SWUBR06-08-20L	8	4	7	10	20	150	M2x5.0x2.6		
○	C1205M-SWUBR06-06-15L	6	3	5	12	15	150	M2x3.7x3.6-60	T6	WB0601
○	C1605M-SWUBR06-06-15L	6	3	5	16	15	150			
合金鋼 (圖一) Alloy Steel (Fig-1)										
●	S0805K-SWUCR02-06-10L	6	3	5	8	10	125	M2x3.7x2.6-60	T6	WC0201
●	S1005K-SWUBR06-06-15L	6	2.8	5	10	15	125	M2x5.0x2.6		WC0601
●	S1006K-SWUBR06-07-18L	7	3.5	6	10	18	125			
●	S1007K-SWUBR06-08-20L	8	4	7	10	20	125			
●	S1205K-SWUBR06-06-15L	6	3	5	12	15	125	M2x3.7x2.6-60		

●:庫存 In Stock    ○:非標準庫存(請確認交貨期) Non-standard Stock

# Zy 微小徑內徑車刀 Mini Boring Bars

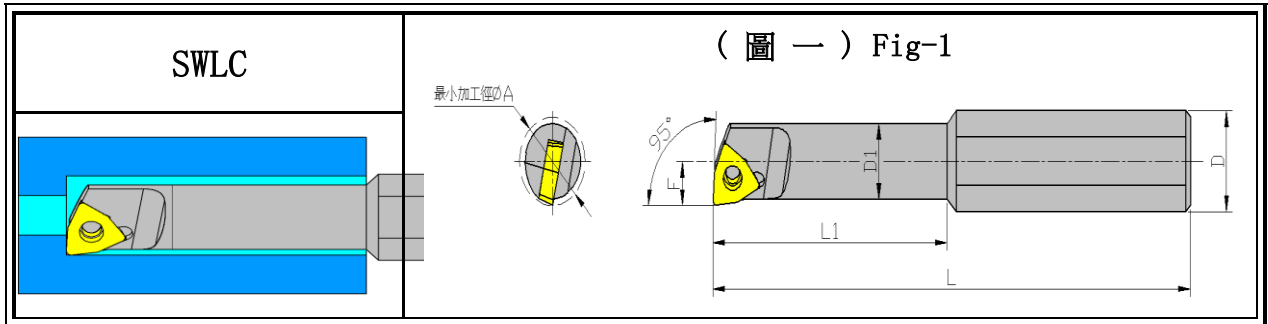

Stock	型號 Model No.	最小加工徑 A	F	D1	D	L1	L	螺絲 Screw	扳手 Wrench	刀片 Insert
合金鋼柄 (圖一) Alloy Steel (Fig-1)										
●	S0805K-SWLCR02-06-10L	6	3	5	8	10	125	M2x3.7x2.6-60	T6	WC0201
○	S0806K-SWLCR02-07-10L	7	3.5	6	8	10	125	M2x5.0x2.6		
●	S1005K-SWLCR02-06-15L	6	3	05	10	15	125			

●:庫存 In Stock ○:非標準庫存(請確認交貨期) Non-standard Stock

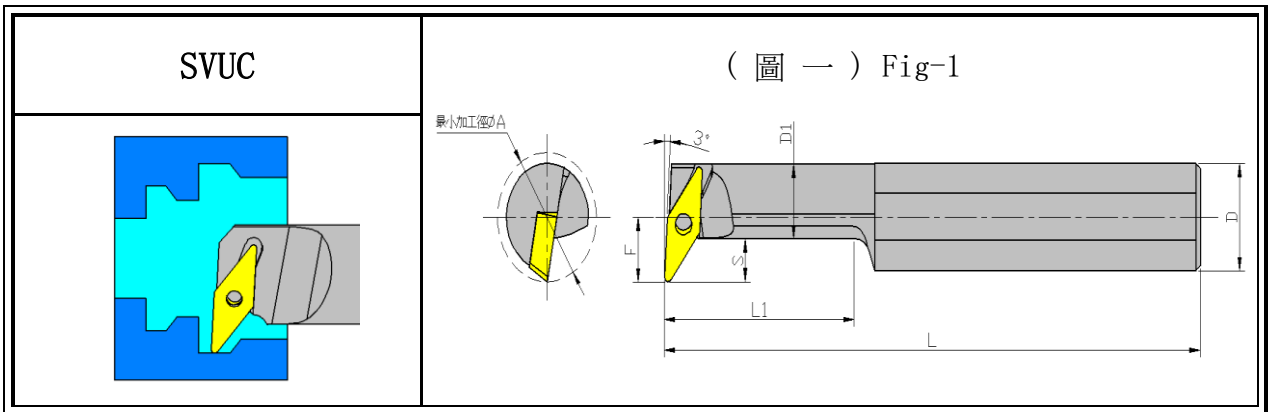

Stock	型號 Model No.	最小加工徑 A	F	D1	D	L1	L	S	螺絲 Screw	扳手 Wrench	刀片 Insert
合金鋼柄 (圖一) Alloy Steel (Fig-1)											
●	S1008K-SVUCR07-12-20L	12	6	8	10	20	125	3	M2x5.0x2.6	T6	VC0702
●	S1210M-SVUCR07-14-30L	14	7	10	12	30	150	3			

●:庫存 In Stock ○:非標準庫存(請確認交貨期) Non-standard Stock



# Zy 微小徑內徑車刀 Mini Boring Bars

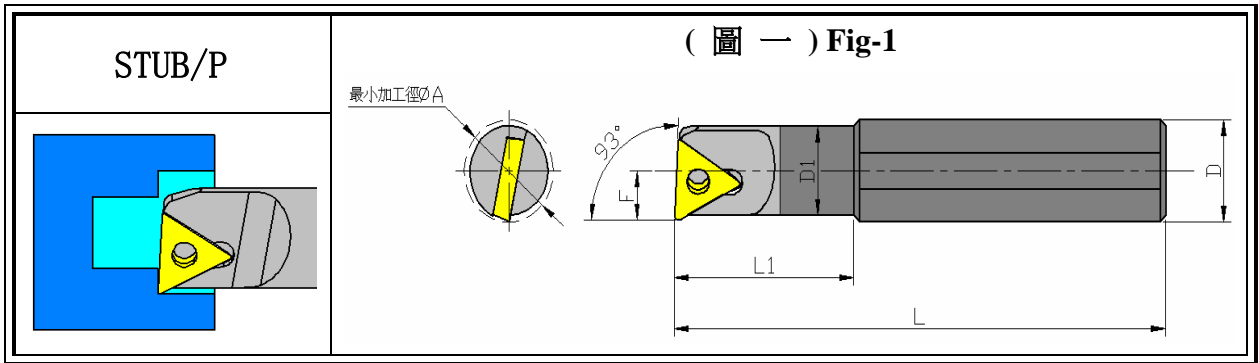

stock	型號 Model No.	最小加工徑 A	F	D1	D	L1	L	螺絲 Screw	板手 Wrench	刀片 Insert
錫鋼柄 (圖一) Carbide Shank (Fig-1)										
●	C0806K-STUBR06-07-20L	7	3.5	6	8	20	125	M2x5.0x2.6	T6	TB0601
●	C0807K-STUBR06-08-20L	8	4	7	8	20	125			
●	C1006M-STUBR06-07-20L	7	3.5	6	10	20	150			
○	C1206M-STUBR06-07-20L	7	3.5	6	12	20	150			
○	C1207M-STUBR06-08-20L	8	4	7	12	20	150			
合金鋼柄 (圖一) Alloy Steel (Fig-1)										
●	S0806K-STUBR06-07-20L	7	3.5	6	8	20	125	M2x5.0x2.6	T6	TB0601
●	S0807K-STUBR06-08-20L	8	4	7	8	20	125			
●	S1006K-STUBR06-07-20L	7	3.5	6	10	20	125			
●	S1206K-STUBR06-07-15L	7	3.5	6	12	15	125			
●	S1207K-STUBR06-08-20L	8	4	7	12	20	125			

●:庫存 In Stock    ○:非標準庫存(請確認交貨期) Non-standard Stock

stock	型號 Model No.	最小加工徑 A	F	D1	D	L1	L	螺絲 Screw	板手 Wrench	刀片 Insert
合金鋼柄 (圖一) Alloy Steel (Fig-1)										
●	S1608K-STUPR08-10-20L	10	5.5	8	16	20	125	M2.2x5.1x3.1	T7	TP0802
●	S1608K-STUPR09-10-20L	10	5.5	8	16	20	125	M2.5x6.0x3.6	T8	TP0902
●	S1610K-STUPR11-12-20L	12	6.5	10	16	20	125	M3x7.8x4.1	T9	TP1102

# Zy 微小徑內徑車刀 Mini Boring Bars

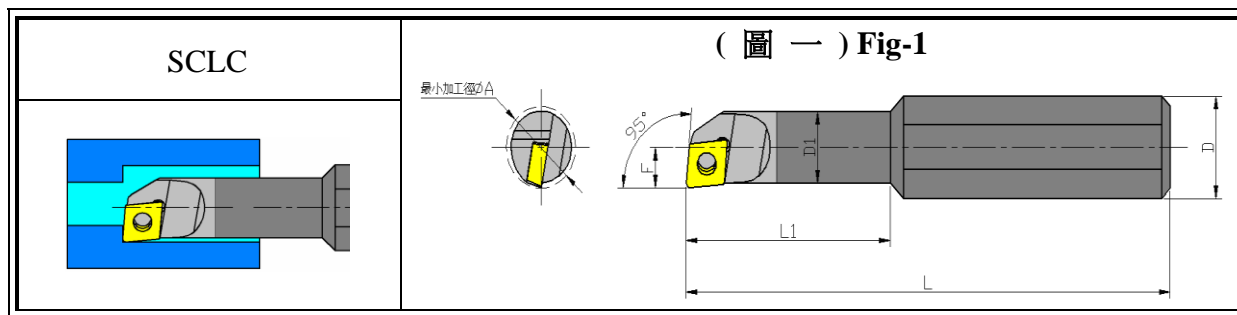

Stock	型號 Model No.	最小加工徑 A	F	D	D1	L1	L	螺絲 Screw	扳手 Wrench	刀片 Insert
鎢鋼柄 (圖一) Carbide Shank (Fig-1)										
●	C0604J-SCLCR03-05-20L	5	2.8	6	4	20	110	M1.8x4.0x2.5-54	T6	CC0301
●	C0605J-SCLCR03-06-10L	6	3	6	5	10	110			
●	C0804K-SCLCR03-05-10L	5	2.8	8	4	10	125			
●	C0805K-SCLCR03-06-10L	6	3	8	5	10	125			
○	C1004M-SCLCR03-05-10L	5	2.5	10	4	10	150			
○	C1204M-SCLCR03-05-10L	5	2.5	12	4	10	150	M2.2x5.1x3.1	T7	CC0401
●	C0807K-SCLCR04-08-20L	8	4	8	7	20	125			
○	C1206M-SCLCR04-07-15L	7	3.5	12	6	15	150	M2.5x6.0x3.6	T8	CC0602
●	C0807K-SCLCR06-08-20L	8	4	8	7	20	125			
○	C1208M-SCLCR06-10-20L	10	5	12	8	20	150			
○	C1607M-SCLCR06-08-20L	8	4	16	7	20	150			
○	C1609M-SCLCR06-10-25L	10	5	16	9	25	150	M4x8.8x5.4	T15	CC09T3
○	C1614R-SCLCR09-16-30L	16	8	16	14	30	200			
合金鋼柄 (圖一) Alloy Steel (Fig-1)										
●	S1004K-SCLCR03-05-10L	5	2.5	10	4	10	125	M1.8x4.0x2.5-54	T6	CC0301
●	S1204K-SCLCR03-05-10L	5	2.5	12	4	10	125			
●	S1205K-SCLCR04-06-15L	6	3	12	5	15	125	M2.2x5.1x3.1	T7	CC0401
●	S1206K-SCLCR04-07-15L	7	3.5	12	6	15	125			
●	C0807K-SCLCR06-08-20L	8	4	8	7	20	125	M2.5x6.0x3.6	T8	CC0602
●	S1208K-SCLCR06-10-20L	10	5	12	8	20	125			
●	S1607K-SCLCR06-08-20L	8	4	16	7	20	125			
●	S1609K-SCLCR06-10-25L	10	5	16	9	25	125			
●	S1614Q-SCLCR09-16-30L	16	8	16	14	30	180	M4x8.8x5.4	T15	CC09T3

# Zy 內徑車刀 Boring Bars

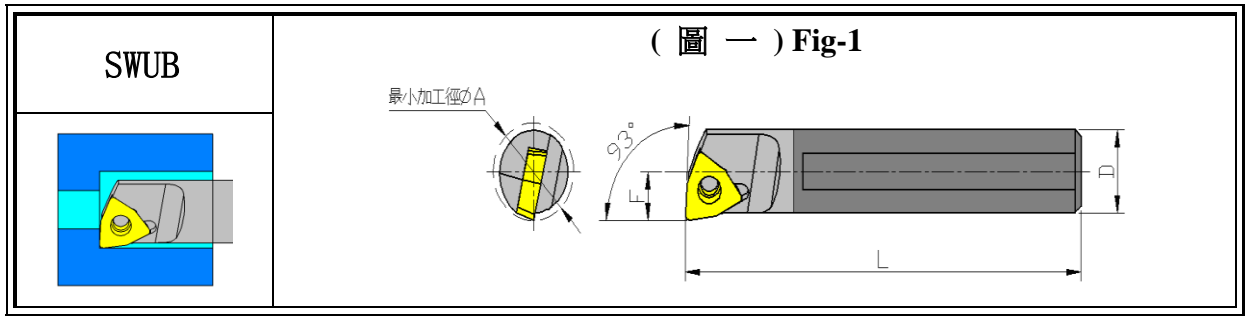



Stock	型號 Model No.	最小加工徑 A	F	D	L	螺絲 Screw	扳手 Wrench	刀片 Insert
鎢鋼柄 (圖一) Carbide Shank (Fig-1)								
●	C04G-SWUBR/L06-055	5.5	2.75	4	90	M2x3.7x2.6-60	T6	WB0601
●	C05H-SWUBR/L06-06	6	3	5	100			
●	C06J-SWUBR/L06-07	7	3.5	6	110	M2x5.0x2.6	T6	WB0601
●	C07J-SWUBR/L06-08	8	4	7	110			
●	C08K-SWUBR/L06-09	9	4.5	8	125			
●	C07J-SWUBR/L06-08	8	4	7	110	M2x5.0x2.6	T6	WB0802
●	C08K-SWUBR/L08-10	10	5	8	125			
●	C10M-SWUBR/L08-12	12	6	10	150			

●:庫存 In Stock    ○:非標準庫存(請確認交貨期) Non-standard Stock

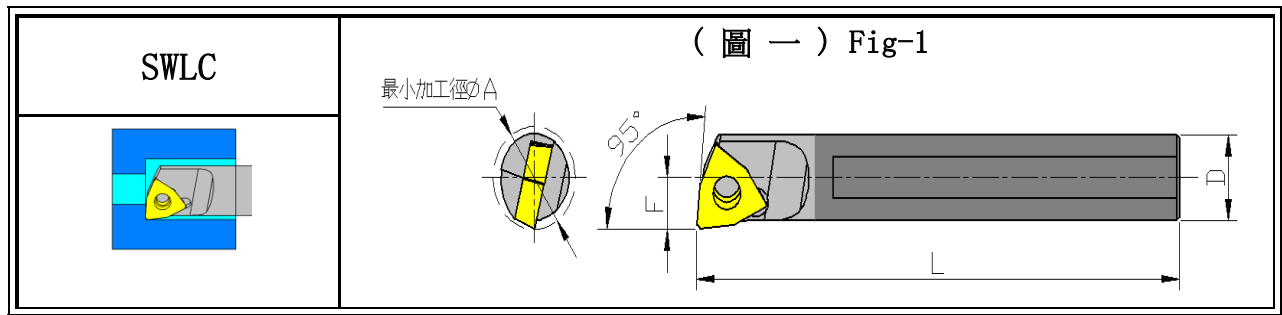
# Zy 內徑車刀 Boring Bars



Stock	型號 Model No.	最小加工徑 A	F	D	L	 螺絲 Screw	 板手 Wrench	刀片 Insert
鎢鋼柄 (圖一) Carbide Shank (Fig-1)								
●	C05H-SWLCR/L02-06	6	3	5	100	M2x5.0x2.6	T6	WC0201
●	C06J-SWLCR/L02-07	7	3.5	6	110			
●	C07J-SWLCR/L02-08	8	4	7	110			

●:庫存 In Stock    ○:非標準庫存(請確認交貨期) Non-standard Stock



# Zy 內徑車刀 Boring Bars

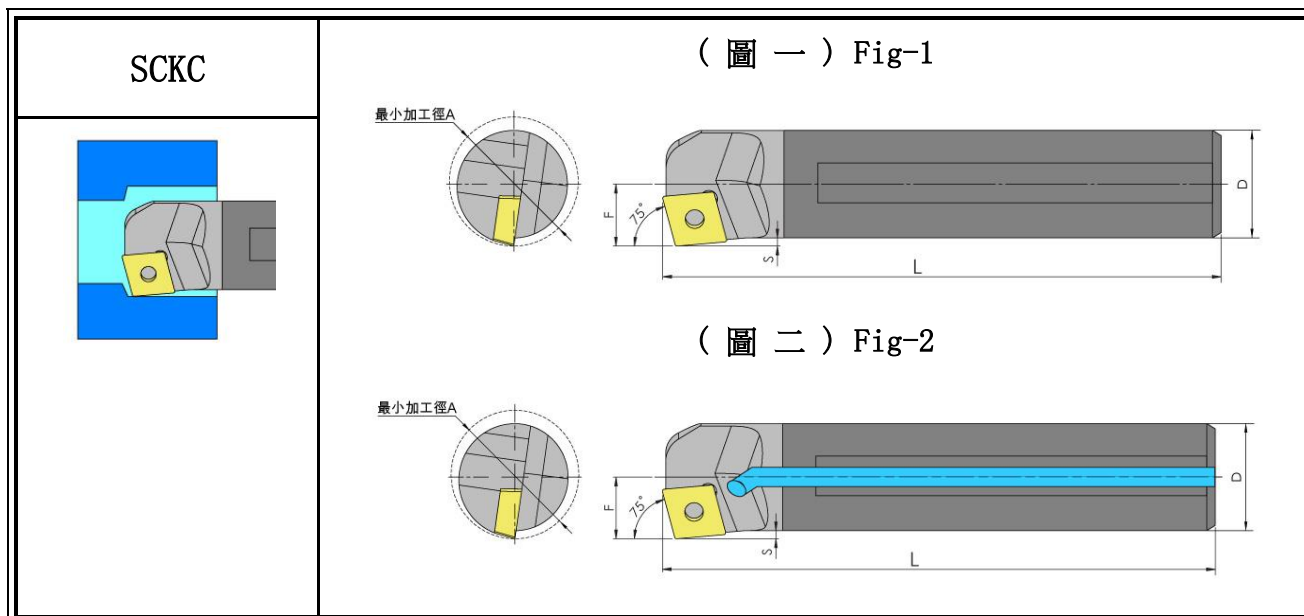

Stock	型號 Model No.	最小加工徑 A	F	D	L	螺絲 Screw	板手 Wrench	刀片 Insert
<b>鎢鋼柄 (圖一) Carbide Shank (Fig-1)</b>								
●	C08K-SCKCR/L06-10	10	5.5	8	125	M2.5x6.0x3.6	T8	CC0602
●	C10M-SCKCR/L06-12	12	6	10	150			
●	C12M-SCKCR/L06-16	16	8	12	150			
●	C12M-SCKCR/L09-16	16	8	12	150	M4x8.8x5.4	T15	CC09T3
●	C14M-SCKCR/L09-17	17	8.5	14	150			
●	C16M-SCKCR/L09-20	20	9.5	16	150			
<b>鎢鋼柄 + 水孔 (圖二) Carbide Shank With Coolant (Fig-2)</b>								
○	E10M-SCKCR/L06-13	13	6	10	150	M2.5x6.0x3.6	T8	CC0602
○	E16M-SCKCR/L09-20	20	9.5	20	150	M4x8.8x5.4	T15	CC09T3
○	E20R-SCKCR/L09-24	24	11.5	20	200			
<b>合金鋼 (圖一) Alloy Steel (Fig-1)</b>								
●	S08K-SCKCR/L06-10	10	5.5	8	125	M2.5x6.0x3.6	T8	CC0602
●	S10K-SCKCR/L06-13	13	6	10	125			
●	S12M-SCKCR/L06-16	16	8	12	150			
●	S12M-SCKCR/L09-16	16	8	12	150	M4x8.8x5.4	T15	CC09T3
●	S16Q-SCKCR/L09-20	20	8.5	16	180			
●	S20R-SCKCR/L09-24	24	11.5	20	200			

# Zy 內徑車刀 Boring Bars

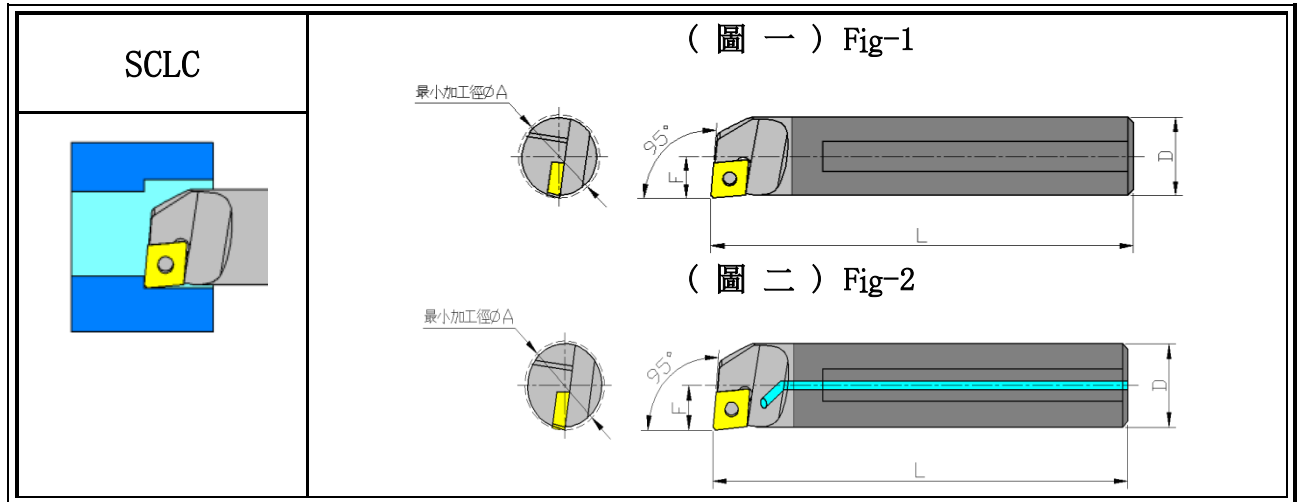

Stock	型號 Model No.	最小加工徑 A	F	D	L	螺絲 Screw	板手 Wrench	刀片 Insert			
鎢鋼柄 (圖一) Carbide Shank (Fig-1)											
●	C04G-SCLCR/L03-045	4.5	2.5	4	90	M1.8x4.0x2.5	T6	CC0301			
●	C04G-SCLCR/L03-05	5	2.8	4	90						
●	C05H-SCLCR/L03-06	6	3	5	100						
●	C05H-SCLCR/L04-06	6	3	5	100	M2.2x5.1x3.1	T7	CC0401			
●	C06J-SCLCR/L04-07	7	3.5	6	110						
●	C07J-SCLCR/L04-08	8	4	7	110						
●	C07J-SCLCR/L06-08	8	4	7	110	M2.5x6.0x3.6	T8	CC0602			
●	C08K-SCLCR/L06-09	9	4.5	8	125						
●	C08K-SCLCR/L06-10	10	5	8	125						
●	C10M-SCLCR/L06-12	12	6	10	150						
●	C12M-SCLCR/L06-14	14	7	12	150						
●	C12Q-SCLCR/L06-14	14	7	12	180						
●	C14M-SCLCR/L06-16	16	8	14	150						
●	C16R-SCLCR/L06-18	18	9	16	200						
●	C12M-SCLCR/L09-14	14	7	12	150				M4x8.8x5.4	T15	CC09T3
●	C12Q-SCLCR/L09-14	14	7	12	180						
●	C14M-SCLCR/L09-16	16	8	14	150						
●	C16M-SCLCR/L09-18	18	9	16	150						
●	C16R-SCLCR/L09-18	18	9	16	200						
●	C20R-SCLCR/L09-22	22	11	20	200						
●	C20S-SCLCR/L09-22	22	11	20	250						
○	C25S-SCLCR/L09-28	28	14.5	25	250						

鎢鋼柄 + 水孔 (圖二) Carbide Shank With Coolant (Fig-2)								
●	E05H-SCLCR/L03-06	6	3	05	100	M1. 8x4. 0x2. -54	T6	CC0301
●	E05H-SCLCR/L04-06	6	3	05	100	M2. 2x5. 1x3. 1	T7	CC0401
●	E06J-SCLCR/L04-07	7	3.5	6	110			
●	E08K-SCLCR/L06-10	10	5	8	125	M2. 5x6. 0x3. 6	T8	CC0602
●	E10M-SCLCR/L06-12	12	6	10	150			
●	E12M-SCLCR/L06-14	14	7	12	150			
●	E12Q-SCLCR/L06-14	14	7	12	180			
●	E14M-SCLCR/L06-16	16	7.5	14	150			
●	E14Q-SCLCR/L06-16	16	7.5	14	180			
○	E16R-SCLCR/L06-18	18	9	16	200			
●	E12M-SCLCR/L09-14	14	7	12	150	M4x8. 8x5. 4	T15	CC09T3
●	E12Q-SCLCR/L09-14	14	7	12	180			
●	E14M-SCLCR/L09-16	16	7.5	14	150			
●	E14Q-SCLCR/L09-16	16	7.5	14	180			
●	E16R-SCLCR/L09-18	18	9	16	200			
●	E20R-SCLCR/L09-22	22	11	20	200			
●	E20S-SCLCR/L09-22	22	11	20	250			
合金鋼柄 (圖一) Alloy Steel (Fig-1)								
●	S08K-SCLCR/L06-10	10	5	8	125	M2. 5x6. 0x3. 6	T8	CC0602
●	S10K-SCLCR/L06-12	12	6	10	125			
●	S12M-SCLCR/L06-14	14	7	12	150			
●	S16Q-SCLCR/L06-18	18	9	16	180			
●	S12M-SCLCR/L09-14	14	7	12	150	M4x8. 8x5. 4	T15	CC09T3
●	S14N-SCLCR/L09-16	16	9	14	160			
●	S16Q-SCLCR/L09-18	18	9	16	180			
●	S20R-SCLCR/L09-22	22	11	20	200			
高硬度柄 (Y:圖二、Z:圖一) High Hardness Steel With Coolant (Y:Fig-1、Z:Fig-2)								
●	Y10K-SCLCR/L06-12	12	6	10	125	M2. 5x6. 0x3. 6	T8	CC0602
●	Y12M-SCLCR/L06-14	14	7	12	150			
●	Z12M-SCLCR/L06-14	14	7	12	150			
●	Y12M-SCLCR/L09-14	14	7	12	150	M4x10. 6x5. 6	T15	CC09T3
●	Z12M-SCLCR/L09-14	14	7	12	150			
○	Y14N-SCLCR/L09-16	16	8	14	160			
●	Y16N-SCLCR/L09-18	18	9	16	160			
●	Y20R-SCLCR/L09-22	22	11	20	200			
●	Z20R-SCLCR/L09-22	22	11	20	200			
●	Y25R-SCLCR/L09-28	28	14.5	25	200			
●	Y32R-SCLCR/L09-38	38	17.5	32	200			

# Zy 內徑車刀 Boring Bars

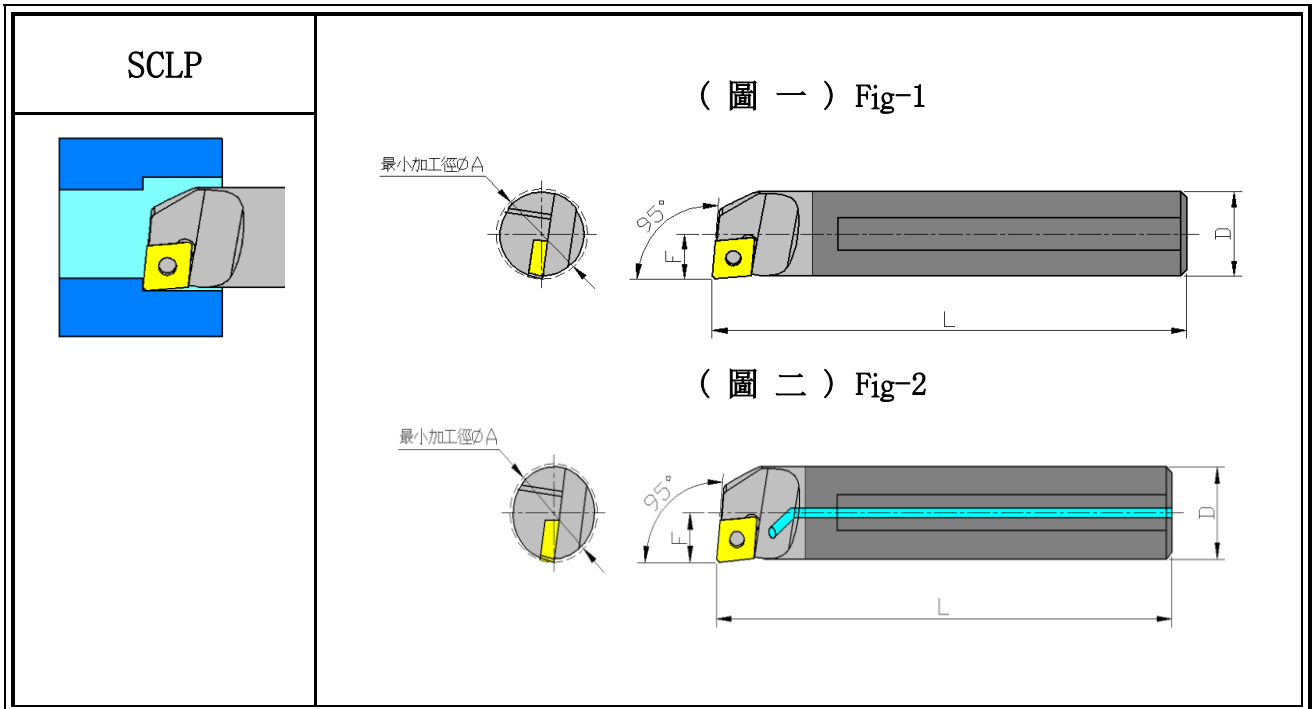

Stock	型號 Model No.	最小加工徑 A	F	D	L	螺絲 Screw	扳手 Wrench	刀片 Insert
<b>鎢鋼柄 (圖一) Carbide Shank (Fig-1)</b>								
○	C08K-SCLPR/L06-10	10	5	8	125	M2.5x6.0x3.6	T8	CP0602
○	C10M-SCLPR/L06-12	12	6	10	150			
○	C12M-SCLPR/L06-15	15	8	12	150			
●	C10M-SCLPR/L08-12	12	6	10	150	M3x7.8x4.1	T9	CP0802
●	C12M-SCLPR/L08-14	14	7	12	150			
○	C12Q-SCLPR/L08-14	14	7	12	180			
●	C12M-SCLPR/L09-14	14	7	12	150	M4x8.8x5.4	T15	CP0903
●	C12Q-SCLPR/L09-14	14	7	12	180			
●	C16R-SCLPR/L09-18	18	9	16	200			
●	C20R-SCLPR/L09-22	22	11	20	200			
●	C20S-SCLPR/L09-22	22	11	20	250			
○	C25R-SCLPR/L09-28	30	14	25	200			
<b>鎢鋼柄 + 水孔 (圖二) Carbide Shank With Coolant (Fig-2)</b>								
●	E16R-SCLPR/L09-18	18	9	16	200	M4x8.0x5.4	T15	CP0903
●	E20R-SCLPR/L09-22	22	11	20	200			
●	E20S-SCLPR/L09-22	22	11	20	250			



○	E25R-SCLPR/L09-28	28	14	25	200			
○	E32S-SCLPR/L09-38	38	17.5	32	250			
<b>合金鋼柄 (圖一) Alloy Steel (Fig-1)</b>								
●	S10K-SCLPR/L08-12	12	6	10	125	M3x7.8x4.1	T9	CP0802
●	S12M-SCLPR/L08-14	14	7	12	150			
●	S12M-SCLPR/L09-14	14	7	12	150	M4x8.8x5.4	T15	CP0903
●	S16Q-SCLPR/L09-18	18	9	16	180			
○	S20R-SCLPR/L09-22	22	11	20	200			
<b>高硬度柄 (Y:圖二、Z:圖一) High Hardness Steel With Coolant (Y:Fig-1、Z:Fig-2)</b>								
●	Y16Q-SCLPR/L09-18	18	9	16	160	M4x8.8x5.4	T15	CP09T3
○	Z16Q-SCLPR/L09-18	18	9	16	160			
○	Y20R-SCLPR/L09-22	22	11	20	200			
●	Z20R-SCLPR/L09-22	22	11	20	200			

●:庫存 In Stock    ○:非標準庫存(請確認交貨期) Non-standard Stock

# Zy 內徑車刀 Boring Bars

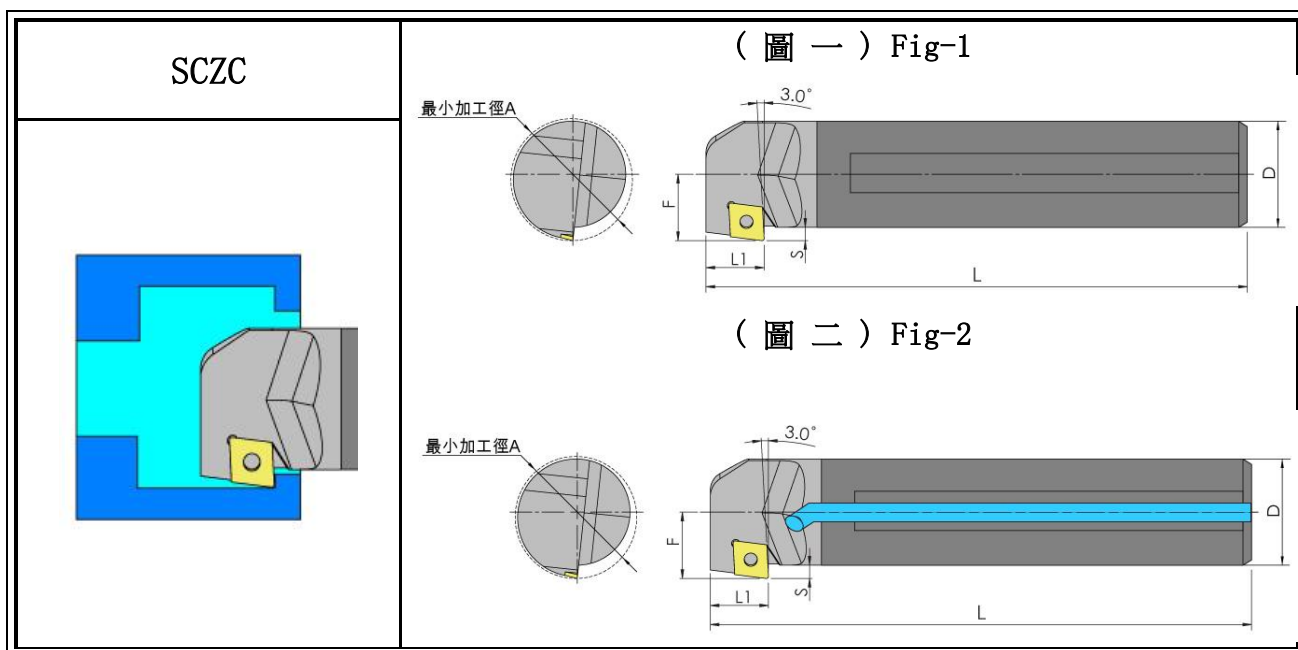

Stock	型號 Model No.	最小加工徑 A	F	D	S	L1	L	螺絲 Screw	扳手 Wrench	刀片 Insert
鎢鋼柄 (圖一) Carbide Shank (Fig-1)										
●	C08K-SCZCR/L06-12	12	6.5	8	2.5	11	125	M2.5x6.0x3.6	T8	CC0602
●	C10M-SCZCR/L06-14	14	7.5	10	2.5	12	150			
●	C12M-SCZCR/L06-16	16	8.5	12	2.5	12	150			
●	C16R-SCZCR/L06-20	20	10.5	16	2.5	12	200			
○	C16R-SCZCR/L09-21	21	11.5	16	3.5	18	200	M4x8.8x5.4	T15	CC09T3
合金鋼柄 (圖一) Alloy Steel (Fig-1)										
●	S08K-SCZCR/L06-12	12	6.5	8	2.5	11	125	M2.5x6.0x3.6	T8	CC0602
●	S10K-SCZCR/L06-14	14	7.5	10	2.5	12	150			
●	S12M-SCZCR/L06-16	16	8.5	12	2.5	12	150			
鎢鋼柄 + 水孔 (圖二) Carbide Shank With Coolant (Fig-2)										
●	C08K-SCZCR/L06-12	12	6.5	8	2.5	11	125	M2.5x6.0x3.6	T8	CC0602
●	C10M-SCZCR/L06-14	14	7.5	10	2.5	12	150			
●	C12M-SCZCR/L06-16	16	8.5	12	2.5	12	150			
●	C16R-SCZCR/L06-20	20	10.5	16	2.5	12	200			

●:庫存 In Stock    ○:非標準庫存(請確認交貨期) Non-standard Stock

# Zy 內徑車刀 Boring Bars

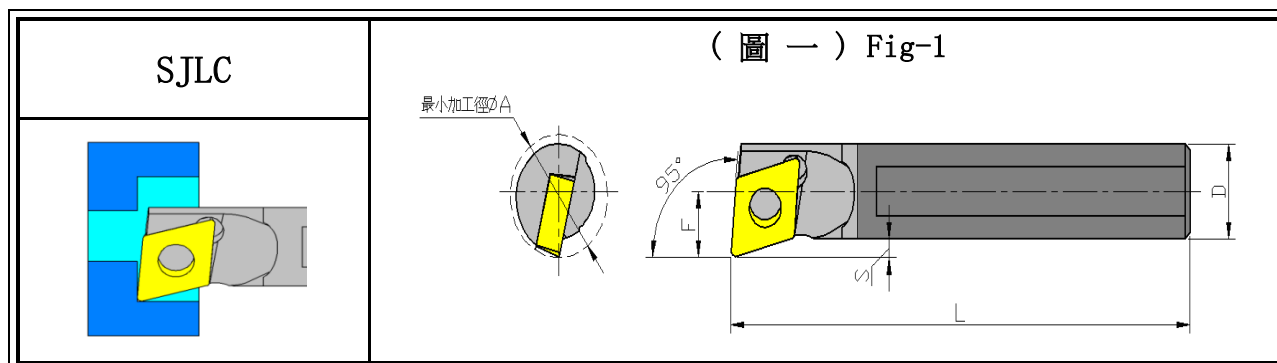

Stock	型號 Model No.	最小加工徑 A	F	D	S	L	螺絲 Screw	扳手 Wrench	刀片 Insert
鎢鋼柄 (圖一) Carbide Shank (Fig-1)									
●	C04G-SJLCR/L03-055	5.5	2.95	4	0.65	90	M1.8x4.0x2.5-54	T6	JC0301

●:庫存 In Stock    ○:非標準庫存(請確認交貨期) Non-standard Stock

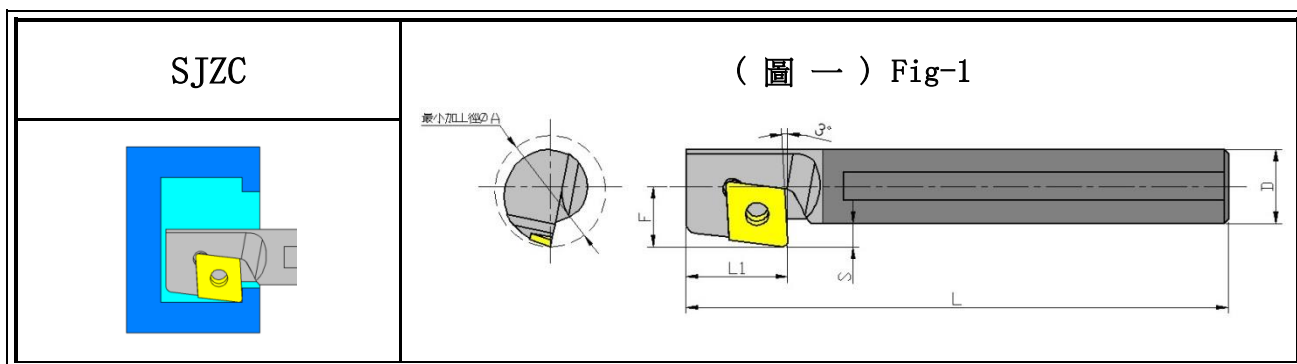

Stock	型號 Model No.	最小加工徑 A	F	D	S	L1	L	螺絲 Screw	扳手 Wrench	刀片 Insert
鎢鋼柄 (圖一) Carbide Shank (Fig-1)										
●	C04G-SJZCR/L03-065	6.5	4	4	1.8	4.8	90	M1.8x4.0x2.5-54	T6	JC0301

●:庫存 In Stock    ○:非標準庫存(請確認交貨期) Non-standard Stock

# Zy 內徑車刀 Boring Bars

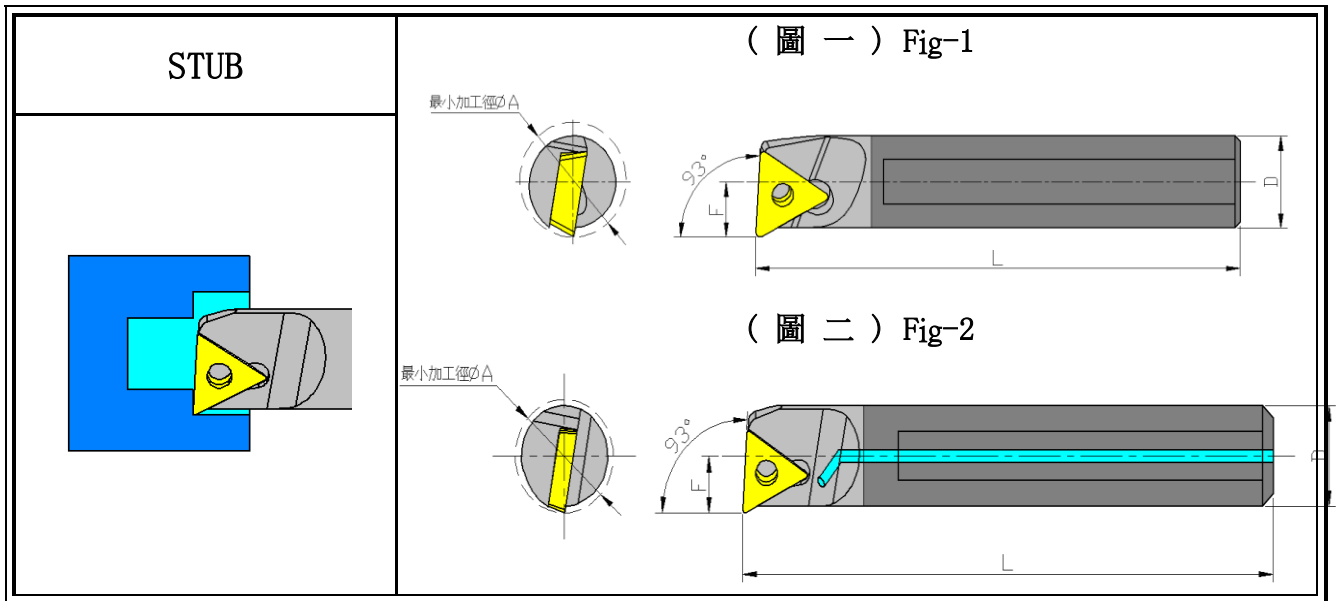

Stock	型號 Model No.	最小加工徑 A	F	D	L	螺絲 Screw	板手 Wrench	刀片 Insert
鎢鋼柄 (圖一) Carbide Shank (Fig-1)								
●	C06J-STUBR/L06-07	7	3.5	6	110	M2x5.0x2.6	T6	TB0601
●	C07J-STUBR/L06-08	8	4	7	110			
●	C08K-STUBR/L06-09	9	4.5	8	125			
●	C10M-STUBR/L06-12	12	5.5	10	150			
鎢鋼柄 + 水孔 (圖二) Carbide Shank With Coolant (Fig-2)								
●	E06J-STUBR/L06-07	7	3.5	6	110	M2x5.0x2.6x60	T6	TB0601
●	E08K-STUBR/L06-09	9	4.5	8	125			
合金鋼柄 (圖一) Alloy Steel (Fig-1)								
●	S08K-STUBR/L06-09	9	4.5	8	125	M2x5.0x2.6x60	T6	TB0601
高硬度柄 (Y:圖二、Z:圖一) High Hardness Steel With Coolant (Y:Fig-1、Z:Fig-2)								
●	Z08H-STUBR/L06-09	9	4.5	8	125	M2x5.0x2.6x60	T6	TB0601

●:庫存 In Stock    ○:非標準庫存(請確認交貨期) Non-standard Stock

# Zy 內徑車刀 Boring Bars

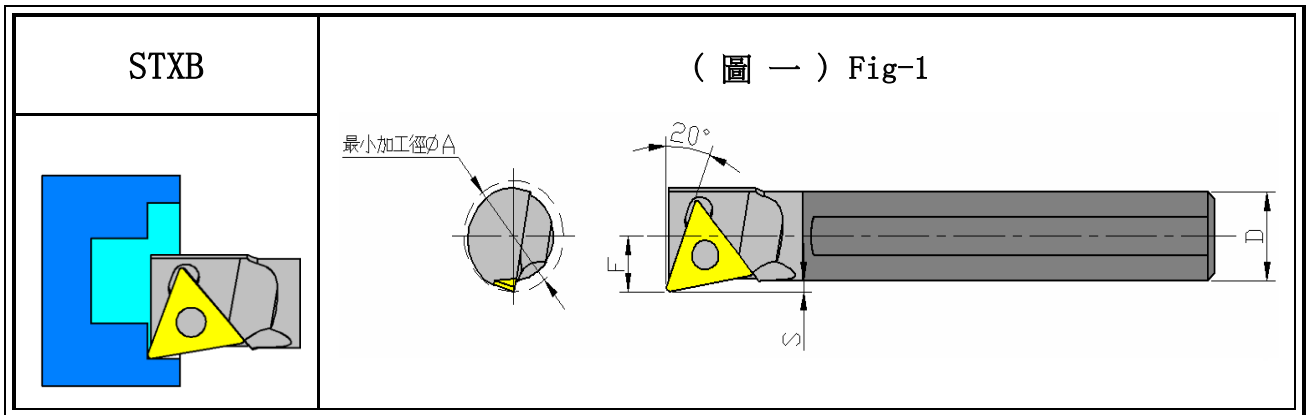

Stock	型號 Model No.	最小加工徑 A	F	D	S	L	螺絲 Screw	扳手 Wrench	刀片 Insert
鎢鋼柄 (圖一) Carbide Shank (Fig-1)									
○	C06J-STXBR/L06-075	7.5	3.75	6	0.5	110	M2x5.0x2.6	T6	TB0601

●:庫存 In Stock    ○:非標準庫存(請確認交貨期) Non-standard Stock

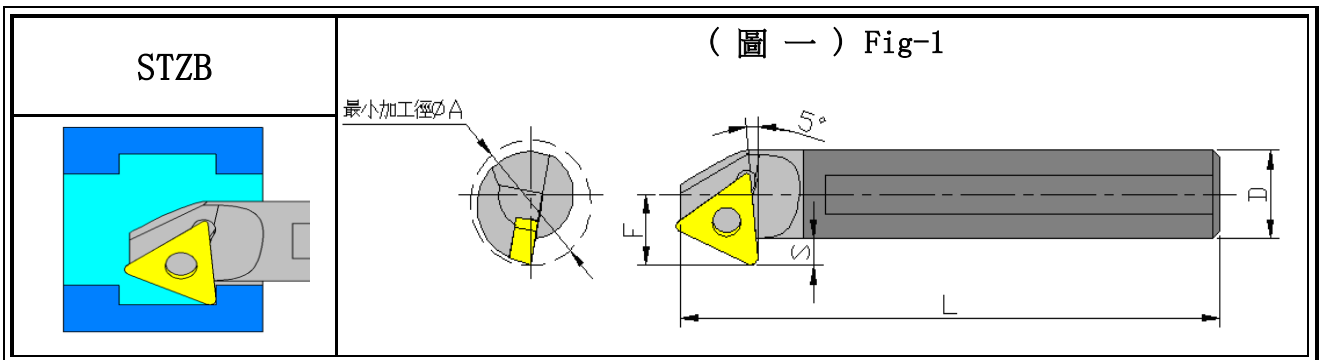

Stock	型號 Model No.	最小加工徑 A	F	D	S	L	螺絲 Screw	扳手 Wrench	刀片 Insert
鎢鋼柄 (圖一) Carbide Shank (Fig-1)									
●	C06J-STZBR/L06-085	8.5	5	6	2	110	M2x5.0x2.6	T6	TB0601

●:庫存 In Stock    ○:非標準庫存(請確認交貨期) Non-standard Stock



# Zy 內徑車刀 Boring Bars

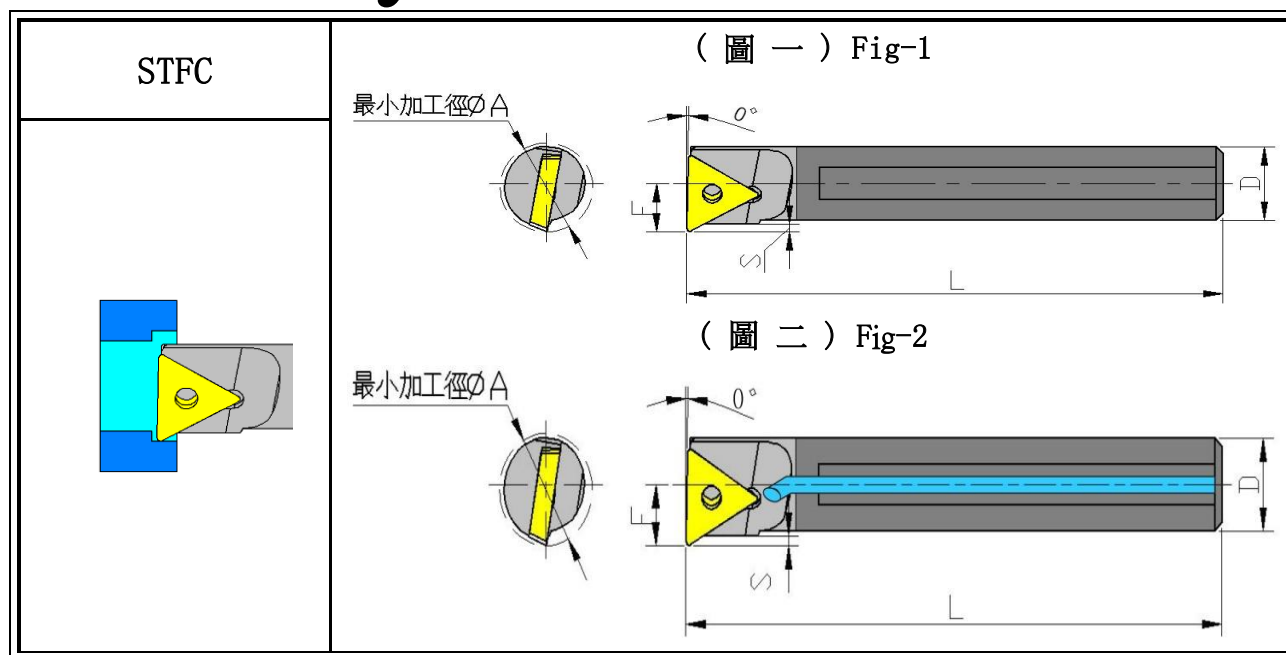

Stock	型號 Model No.	最小加工徑 A	F	D	L	S	螺絲 Screw	板手 Wrench	刀片 Insert
鎢鋼柄 (圖一) Carbide Shank (Fig-1)									
○	C06J-STFCR/L06-07	7	3.5	6	110	0.5	M2x3.7x2.6	T6	TC0604
●	C08K-STFCR/L09-10	10	5.5	8	125	1.5	M2.2x5.1x3.1	T7	TC0902
●	C10M-STFCR/L09-12	12	6	10	150	1			
○	C10M-STFCR/L11-12	12	6	10	150	1	M2.5x6.0x3.6	T8	TC1102
●	C12M-STFCR/L11-14	14	7.5	12	150	2			
●	C14Q-STFCR/L11-17	17	9	14	180	2			
●	C16R-STFCR/L11-18	18	9.5	16	200	2			
○	C20R-STFCR/L11-22	22	11	20	200	1	M4x8.8x5.4	T15	TC16T3
○	C16R-STFCR/L16-20	20	10	16	200	2			
○	C20R-STFCR/L16-22	22	11.5	20	200	3			
○	C25R-STFCR/L16-30	30	15	25	200	2.5			
○	C32S-STFCR/L16-38	38	20	32	250	4			
鎢鋼柄 + 水孔 (圖二) Carbide Shank With Coolant (Fig-2)									
●	E16R-STFCR/L11-18	18	9.5	16	200	2	M2.5x6.0x3.6	T8	TC1102
●	E20R-STFCR/L11-22	22	11	20	200	1			
合金鋼柄 (圖一) Alloy Steel (Fig-1)									
●	S08K-STFCR/L09-10	10	5.5	8	125	1.5	M2.2x5.1x3.1	T7	TC0902
●	S10K-STFCR/L09-12	12	6.5	10	125	1			

●	S10K-STFCR/L11-12	12	6.5	10	125	1	M2. 5x6. 0x3. 6	T8	TC1102
●	S12M-STFCR/L11-14	14	7.5	12	150	2			
●	S16Q-STFCR/L11-18	18	9.5	16	180	2			
○	S20R-STFCR/L11-22	22	11.5	20	200	1			
●	S20R-STFCR/L16-22	22	11.5	20	200	1	M4x8. 8x5. 4	T15	TC16T3

●:庫存 In Stock    ○:非標準庫存(請確認交貨期) Non-standard Stock

# Zy 內徑車刀 Boring Bars

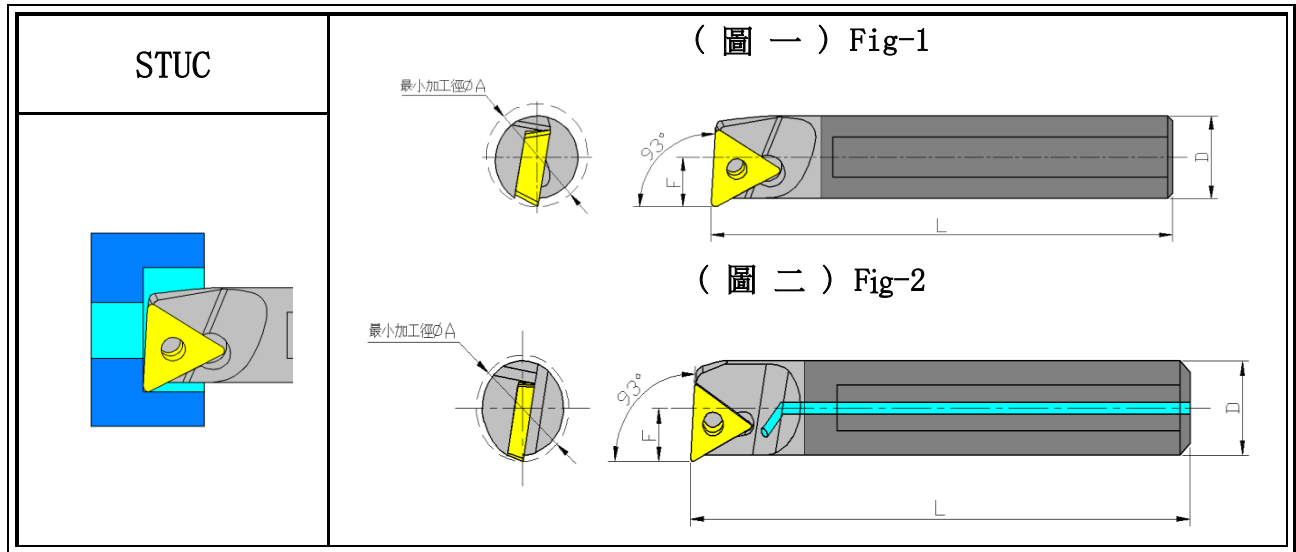

Stock	型號 Model No.	最小加工徑 A	F	D	L	螺絲 Screw	扳手 Wrench	刀片 Insert
鎢鋼柄 (圖一) Carbide Shank (Fig-1)								
●	C06J-STUCR/L06-07	7	3.5	6	110	M2x3.7x2.6	T6	TC0601
●	C07J-STUCR/L06-08	8	4	7	110	M2x5.0x2.6		
○	C08K-STUCR/L06-10	10	4.5	8	125			
●	C08K-STUCR/L09-10	10	5	8	125	M2.2x5.1x3.1	T7	TC0902
●	C10M-STUCR/L09-12	12	6	10	150			
●	C12M-STUCR/L09-14	14	7	12	150			
●	C12Q-STUCR/L09-14	14	7	12	180			
●	C10M-STUCR/L11-12	12	6	10	150	M2.5x6.0x3.6	T8	TC1102
●	C12M-STUCR/L11-14	14	7	12	150			
●	C12Q-STUCR/L11-14	14	7	12	180			
●	C14M-STUCR/L11-16	16	8	14	150			
●	C16M-STUCR/L11-18	18	9	16	150			
●	C16R-STUCR/L11-18	18	9	16	200			
●	C20R-STUCR/L11-22	22	11	20	200			
●	C20S-STUCR/L11-22	22	11	20	250			
○	C25R-STUCR/L11-28	28	14	25	200			
●	C25S-STUCR/L11-28	28	14	25	250			
○	C20R-STUCR/L16T3-22	22	11	20	200	M4x8.8x5.4	T15	TC16T3
○	C25R-STUCR/L16T3-28	28	14	25	200			
○	C25S-STUCR/L16T3-28	28	14	25	250			

○	C32S-STUCR/L16T3-38	38	17.5	32	250						
<b>鎢鋼柄 + 水孔 (圖二) Carbide Shank With Coolant (Fig-2)</b>											
●	E06J-STUCR/L06-07	7	3.5	6	110	M2x3.7x2.6	T6	TC0601			
●	E08K-STUCR/L09-10	10	5	8	125	M2.2x5.1x3.1	T7	TC0902			
●	E10M-STUCR/L09-12	12	6	10	150						
●	E12M-STUCR/L09-14	14	7	12	150						
●	E10M-STUCR/L11-12	12	6	10	150	M2.5x6.0x3.6	T8	TC1102			
●	E12M-STUCR/L11-14	14	7	12	150						
●	E12Q-STUCR/L11-14	14	7	12	180						
●	E14M-STUCR/L11-16	16	8	14	150						
●	E14Q-STUCR/L11-16	16	8	14	180						
●	E16M-STUCR/L11-18	18	9	16	150						
●	E16R-STUCR/L11-18	18	9	16	200						
●	E20R-STUCR/L11-22	22	11	20	200						
●	E20S-STUCR/L11-22	22	11	20	250						
<b>合金鋼柄 (圖一) Alloy Steel (Fig-1)</b>											
●	S08K-STUCR/L09-10	10	5	8	125	M2.2x5.1x3.1	T7	TC0902			
●	S10K-STUCR/L09-12	12	6	10	125						
●	S12M-STUCR/L09-14	14	7	12	150						
●	S10K-STUCR/L11-12	12	6	10	125	M2.5x6.0x3.6	T8	TC1102			
●	S12M-STUCR/L11-14	14	7	12	150						
●	S14N-STUCR/L11-16	16	8	14	160						
●	S16Q-STUCR/L11-18	18	9	16	180						
●	S20R-STUCR/L11-22	22	11	20	200						
○	S20S-STUCR/L11-22	22	11	20	250						
●	S25R-STUCR/L11-28	28	14	25	200						
○	S25S-STUCR/L11-28	28	14	25	250						
●	S20R-STUCR/L16-22	22	11	20	200				M4x8.8x5.4	T15	TC16T3
●	S25R-STUCR/L16-28	28	14	25	200						
<b>高硬度柄 (Y:圖二、Z:圖一) High Hardness Steel With Coolant (Y:Fig-1、Z:Fig-2)</b>											
●	Y10K-STUCR/L09-12	12	6	10	125	M2.2x5.1x3.1	T7	TC0902			
●	Y12M-STUCR/L09-14	14	7	12	150						
●	Z08H-STUCR/L09-10	10	5	8	100						
●	Z12M-STUCR/L09-14	14	7	12	150						
●	Y10K-STUCR/L11-12	12	6	10	125	M2.5x6.0x3.6	T8	TC1102			
●	Y12M-STUCR/L11-14	14	7	12	150						
●	Y14N-STUCR/L11-16	16	8	14	160						
●	Y16N-STUCR/L11-18	18	9	16	160						
○	Y20R-STUCR/L11-22	22	11	20	200						

○	Y20S-STUCR/L11-22	22	11	20	250			
○	Y25R-STUCR/L11-28	28	14	25	200			
○	Y25S-STUCR/L11-28	28	14	25	250			
●	Z10K-STUCR/L11-12	12	6	10	125			
●	Z12M-STUCR/L11-14	14	7	12	150			
●	Z16M-STUCR/L11-18	18	9	16	150			
●	Z16Q-STUCR/L11-18	18	9	16	180			
●	Z20R-STUCR/L11-22	22	11	20	200			
●	Y25R-STUCR/L16T3-28	28	14	25	200	M4x8. 8x5. 4	T15	TC16T3
○	Y25S-STUCR/L16T3-28	28	14	25	200			
●	Y40T-STUCR/L16T3-43	43	21. 5	40	300			
●	Y50U-STUCR/L16T3-53	53	27	50	350			
●	Z25R-STUCR/L16T3-28	28	14	25	200			

●:庫存 In Stock    ○:非標準庫存(請確認交貨期) Non-standard Stock



# Zy 內徑車刀 Boring Bars

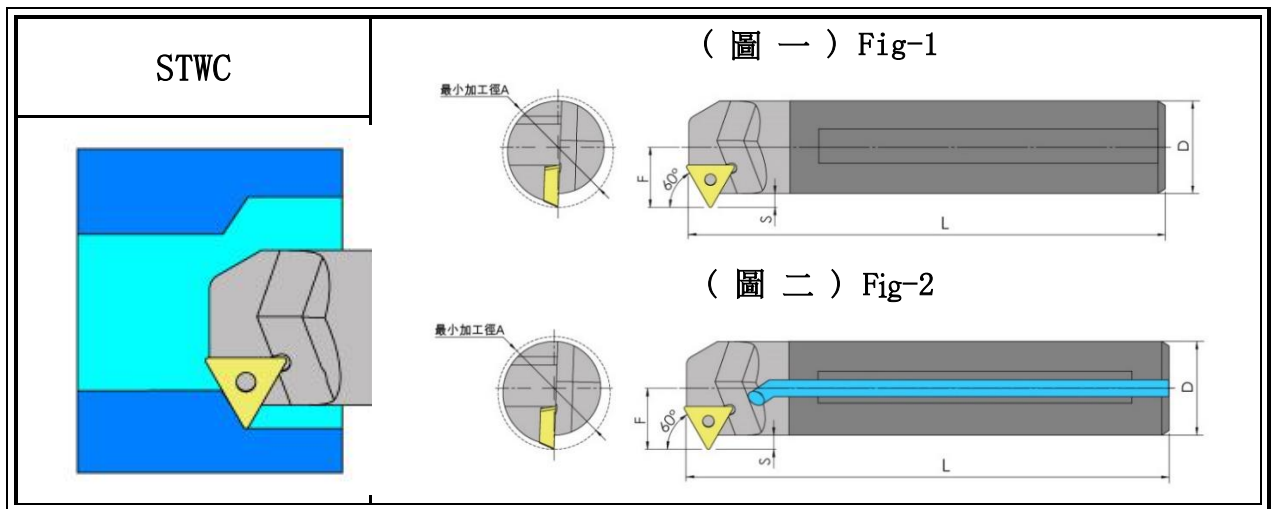

Stock	型號 Model No.	最小加工徑 A	F	D	L	S	螺絲 Screw	板手 Wrench	刀片 Insert
鎢鋼柄 (圖一) Carbide Shank (Fig-1)									
●	C08K-STWCR/L06-10	10	5	8	125	1	M2x5.0x2.6	T6	TC0601
●	C08K-STWCR/L09-11	11	5.5	8	125	1.5	M2.2x5.1x3.1	T7	TC0902
●	C10M-STWCR/L11-14	14	8	10	150	3	M2.5x6.0x3.6	T8	TC1102
●	C12M-STWCR/L11-16	16	9	12	150	3			
●	C16M-STWCR/L11-20	20	11	16	150	3			
●	C16R-STWCR/L11-20	20	11	16	200	3			
○	C20R-STWCR/L11-25	25	13	20	200	3			
○	C20S-STWCR/L11-25	25	13	20	250	3			
○	C25R-STWCR/L11-31	31	15	25	200	2.5			
○	C32S-STWCR/L11-39	39	19	32	250	3			
合金鋼柄 (圖一) Alloy Steel (Fig-1)									
●	S08K-STWCR/L09-11	11	5.5	8	125	1.5	M2.2x5.1x3.1	T7	TC0902
●	S10K-STWCR/L11-14	14	8	10	125	3	M2.5x6.0x3.6	T8	TC1102
●	S12M-STWCR/L11-16	16	9	12	150	3			
●	S16Q-STWCR/L11-20	20	11	16	180	3			
●	S20R-STWCR/L11-25	25	13	20	200	3			
高硬度柄 (Y:圖二、Z:圖一) High Hardness Steel With Coolant (Y:Fig-1、Z:Fig-2)									
●	Y12M-STWCR/L11-16	16	9	12	150	3	M2.5x6.0x3.6	T8	TC1102
●	Y16N-STWCR/L11-20	20	11	16	150	3			
●	Y20R-STWCR/L11-25	25	13	20	250	3			

# Zy 內徑車刀 Boring Bars

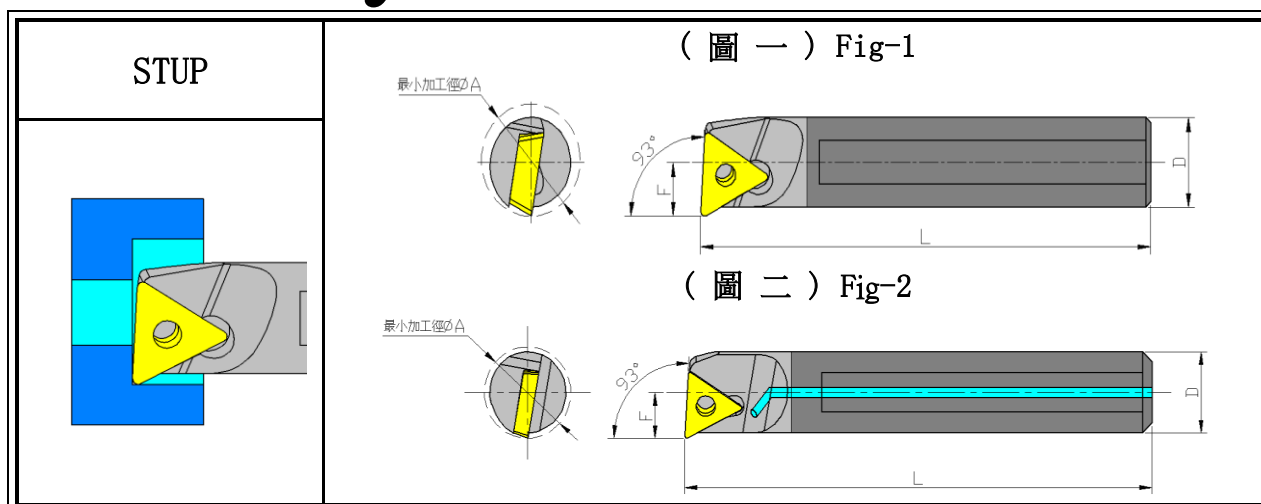

Stock	型號 Model No.	最小加工徑 A	F	D	L	螺絲 Screw	板手 Wrench	刀片 Insert
錐鋼柄 (圖一) Carbide Shank (Fig-1)								
●	C08K-STUPR/L08-10	10	5.5	8	125	M2.2x5.1x3.1	T7	TP0802
●	C10M-STUPR/L08-12	12	6.5	10	150			
●	C12M-STUPR/L08-14	14	7	12	150			
●	C16R-STUPR/L08-18	18	9	16	200			
●	C08K-STUPR/L09-10	10	5.5	8	125	M2.5x6.0x3.6	T8	TP0902
●	C10M-STUPR/L09-12	12	6.5	10	150			
●	C12M-STUPR/L09-14	14	7.5	12	150			
●	C12Q-STUPR/L09-14	14	7.5	12	180			
●	C10M-STUPR/L1102-12	12	6.5	10	150	M2.5x6.0x3.6	T8	TP1102
●	C12M-STUPR/L1102-14	14	7.5	12	150			
●	C16R-STUPR/L1102-18	18	9.5	16	200			
●	C10M-STUPR/L11-12	12	6.5	10	150	M3x7.8x4.1	T9	TP1103
●	C12M-STUPR/L11-14	14	7.5	12	150			
●	C12Q-STUPR/L11-14	14	7.5	12	180			
●	C14M-STUPR/L11-16	16	8.5	14	150			
●	C16M-STUPR/L11-18	18	9.5	16	150			
●	C16R-STUPR/L11-18	18	9.5	16	200			
●	C20R-STUPR/L11-22	22	11.5	20	200			
●	C20S-STUPR/L11-22	22	11.5	20	250			
○	C25R-STUPR/L11-30	30	15	25	200			
○	C25S-STUPR/L11-30	30	15	25	20			
○	C25R-STUPR/L1603-28	28	14	25	200	M4x8.8x5.4	T15	TP1603
○	C25S-STUPR/L1603-28	28	14	25	250			
○	C25R-STUPR/L16T3-28	28	14	25	200			

○	C25S-STUPR/L16T3-28	28	14	25	250			
○	C25R-STUPR/L1604-28	28	14	25	200	M4x8.8x5.4	T15	TP1604
○	C25S-STUPR/L1604-28	28	14	25	250			
<b>鎢鋼柄 + 水孔 (圖二) Carbide Shank With Coolant (Fig-2)</b>								
●	E08K-STUPR/L08-10	10	5.5	8	125	M2.2x5.1x3.1	T7	TP0802
●	E08K-STUPR/L09-10	10	5.5	8	125	M2.5x6.0x3.6	T8	TP0902
●	E10M-STUPR/L09-12	12	6.5	10	150			
●	E12M-STUPR/L09-14	14	7.5	12	150			
●	E10M-STUPR/L11-12	12	6.5	10	150	M3x7.8x4.1	T9	TP1103
●	E12M-STUPR/L11-14	14	7.5	12	150			
●	E12Q-STUPR/L11-14	14	7.5	12	180			
●	E14M-STUPR/L11-16	16	8.5	14	150			
●	E14Q-STUPR/L11-16	16	8.5	14	180			
●	E16M-STUPR/L11-18	18	9.5	16	150			
●	E16R-STUPR/L11-18	18	9.5	16	200			
●	E20R-STUPR/L11-22	22	11.5	20	200			
●	E20S-STUPR/L11-22	22	11.5	20	250			
<b>合金鋼柄 (圖一) Alloy Steel (Fig-1)</b>								
●	S08K-STUPR/L08-10	10	5.5	8	125	M2.2x5.1x3.1	T7	TP0802
●	S10K-STUPR/L08-12	12	6.5	10	125			
●	S08K-STUPR/L09-10	10	5.5	8	125	M2.5x6.0x3.6	T8	TP0902
●	S10K-STUPR/L09-12	12	6.5	10	125			
●	S12M-STUPR/L09-14	14	7.5	12	150			
●	S10K-STUPR/L11-12	12	6.5	10	125	M3x7.8x4.1	T9	TP1103
●	S12M-STUPR/L11-14	14	7.5	12	150			
●	S14N-STUPR/L11-16	16	8.5	14	160			
●	S16Q-STUPR/L11-18	18	9.5	16	180			
●	S20R-STUPR/L11-22	22	11.5	20	200			
●	S25R-STUPR/L11-30	30	15	25	200			
○	S25R-STUPR/L16-32	32	16	25	200	M4x8.8x5.4	T15	TP1604
<b>高硬度柄 (Y:圖二、Z:圖一) High Hardness Steel With Coolant (Y:Fig-1、Z:Fig-2)</b>								
●	Y10K-STUPR/L09-12	12	6.5	10	125	M2.5x6.0x3.6	T8	TP0902
●	Y12M-STUPR/L09-14	14	7.5	12	150			
●	Z08H-STUPR/L09-10	10	5.5	8	100			
●	Z10H-STUPR/L09-12	12	6.5	10	125			
●	Y10K-STUPR/L11-12	12	6.5	10	125	M3x7.8x4.1	T9	TP1103
●	Y12M-STUPR/L11-14	14	7.5	12	150			
○	Y14N-STUPR/L11-16	16	8.5	14	150			
●	Y16N-STUPR/L11-18	18	9.5	16	160			

●	Y20R-STUPR/L11-22	22	11.5	20	200			
●	Y25R-STUPR/L11-30	30	15	25	200			
○	Z12M-STUPR/L11-14	14	7.5	12	150			
○	Z16M-STUPR/L11-18	18	9.5	16	150			
○	Z16Q-STUPR/L11-18	18	9.5	16	180			
●	Z20R-STUPR/L11-22	22	11.5	20	200			
●	Y25R-STUPR/L1603-28	28	14	25	200	M4x8.8x5.4	T15	TP1603
●	Y32S-STUPR/L1603-38	38	17.5	32	250			
●	Z25R-STUPR/L1603-28	28	14	25	200			
●	Y25R-STUPR/L16T3-28	28	14	25	200	M4x8.8x5.4	T15	TP16T3
●	Y20R-STUPR/L1604-25	25	13	20	200	M4x8.8x5.4	T15	TP1604
●	Y25R-STUPR/L1604-28	28	14	25	200			
●	Z20R-STUPR/L1604-25	25	13	20	200			
●	Z25R-STUPR/L1604-28	28	14	25	200			

●:庫存 In Stock    ○:非標準庫存(請確認交貨期) Non-standard Stock

# Zy 內徑車刀 Boring Bars

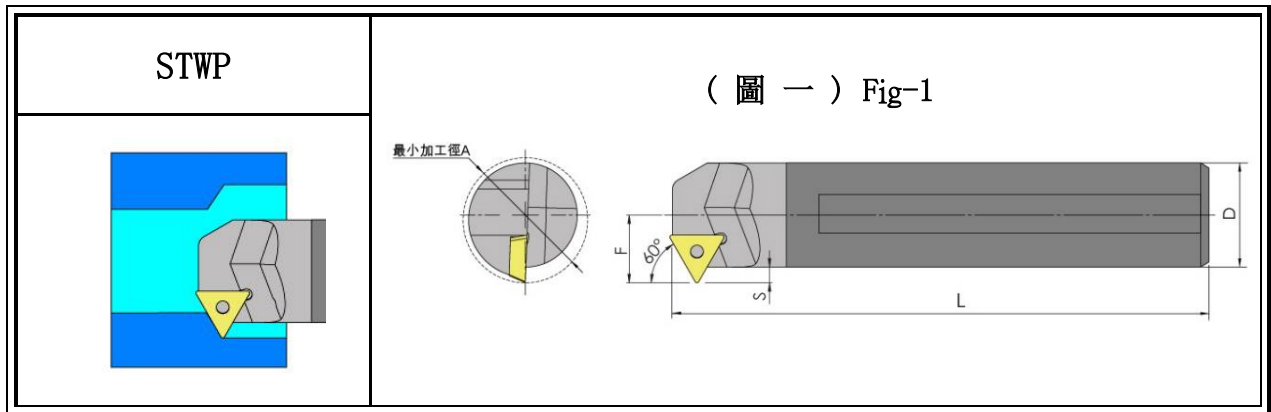

Stock	型號 Model No.	最小加工徑 A	F	D	L	S	螺絲 Screw	板手 Wrench	刀片 Insert
<b>鎢鋼柄 (圖一) Carbide Shank (Fig-1)</b>									
●	C10M-STWPR/L11-13	13	7.5	10	125	2.5	M2.5x6.0x3.6	T8	TP1103
●	C12M-STWPR/L11-16	16	9	12	150	3			
○	C16M-STWPR/L11-20	20	11	16	150	3			
●	C16R-STWPR/L11-20	20	11	16	200	3			
○	C20R-STWPR/L11-25	25	13	20	200	3			
<b>合金鋼柄 (圖一) Alloy Steel (Fig-1)</b>									
●	S10K-STWPR/L11-13	13	7.5	10	125	2.5	M2.5x6.0x3.6	T8	TP1103
●	S12M-STWPR/L11-16	16	9	12	150	3			
●	S16Q-STWPR/L11-20	20	11	16	180	3			
●	S20R-STWPR/L11-25	25	13	20	200	3			

●:庫存 In Stock    ○:非標準庫存(請確認交貨期) Non-standard Stock

# Zy 內徑車刀 Boring Bars

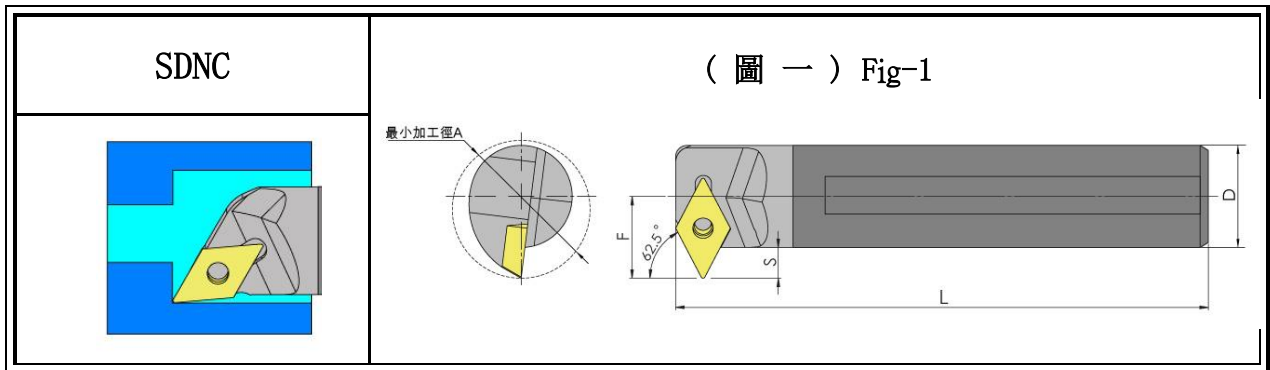

Stock	型號 Model No.	最小加工徑 A	F	D	L	 螺絲 Screw	 板手 Wrench	刀片 Insert
合金鋼柄 (圖一) Alloy Steel (Fig-1)								
●	S16Q-SDNCR/L07-20	20	11	16	180	M2.5x6.0x3.6	T8	DC0702
●	S20R-SDNCR/L11-27	27	16	20	250	M4x8.8x5.4	T15	DC11T3

●:庫存 In Stock    ○:非標準庫存(請確認交貨期) Non-standard Stock



# Zy 內徑車刀 Boring Bars

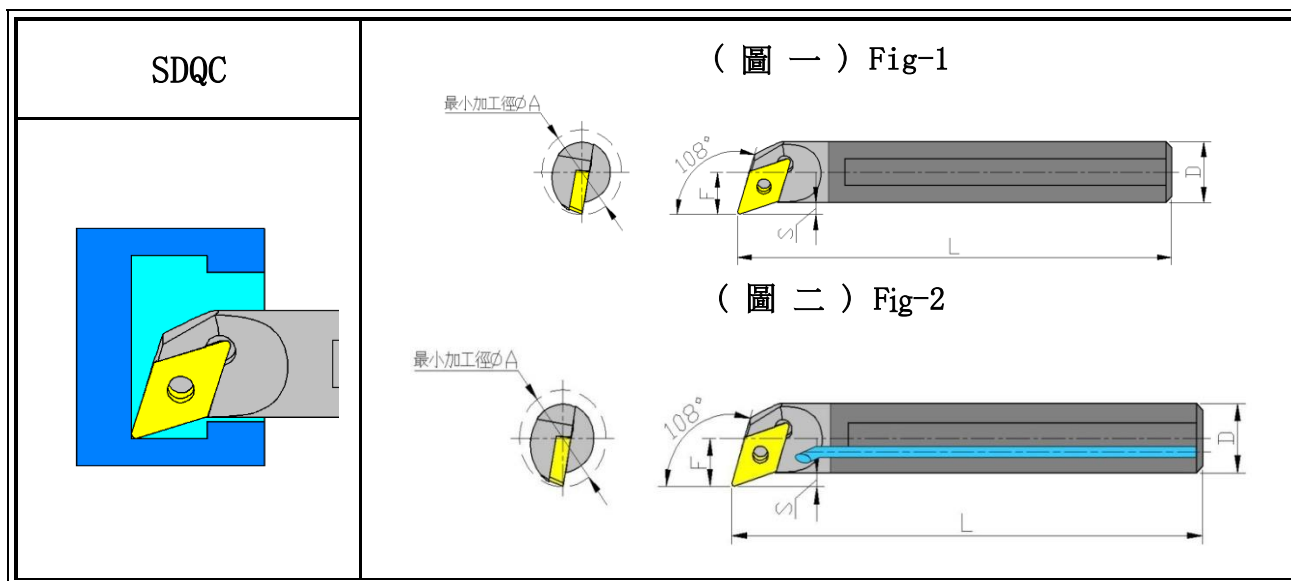



Stock	型號 Model No.	最小加工徑 A	F	D	L	S	螺絲 Screw	板手 Wrench	刀片 Insert
鎢鋼柄 (圖一) Carbide Shank (Fig-1)									
●	C10M-SDQCR/L07-13	13	7	10	150	2	M2.5x6.0x3.6	T8	DC0702
●	C12M-SDQCR/L07-16	16	9	12	150	3			
●	C12Q-SDQCR/L07-16	16	9	12	180	3			
●	C14M-SDQCR/L07-18	18	10	14	150	3			
●	C16M-SDQCR/L07-20	20	11	16	150	3			
●	C16R-SDQCR/L07-20	20	11	16	200	3			
●	C16M-SDQCR/L11-20	20	11	16	150	3	M4x8.8-5.4	T15	DC11T3
●	C16R-SDQCR/L11-20	20	11	16	200	3			
●	C20R-SDQCR/L11-25	25	13	20	200	3			
●	C20S-SDQCR/L11-25	25	13	20	250	3			
○	C25R-SDQCR/L11-32	32	17	25	200	4.5			
●	C25S-SDQCR/L11-32	32	17	25	250	4.5			
○	C32S-SDQCR/L11-40	40	20	32	250	4			
鎢鋼柄 + 水孔 (圖二) Carbide Shank With Coolant (Fig-2)									
●	E10M-SDQCR/L07-13	13	7	10	150	2	M2.5x6.0x3.6	T8	DC0702
●	E12M-SDQCR/L07-16	16	9	12	150	3			
●	E12Q-SDQCR/L07-16	16	9	12	180	3			
●	E14M-SDQCR/L07-18	18	10	14	150	3			
●	E16M-SDQCR/L07-20	20	11	16	150	3			

●	E16R-SDQCR/L07-20	20	11	16	200	3			
●	E16M-SDQCR/L11-20	20	11	16	150	3	M4x8. 8x-5. 4	T15	DC11T3
●	E16R-SDQCR/L11-20	20	11	16	200	3			
●	E20R-SDQCR/L11-25	25	13	20	200	3			
●	E20S-SDQCR/L11-25	25	13	20	250	3			
●	E25R-SDQCR/L11-32	32	17	25	200	4. 5			
●	E25S-SDQCR/L11-32	32	17	25	250	4. 5			
●	E32S-SDQCR/L11-40	40	20	32	250	4			
合金鋼柄 (圖一) Alloy Steel (Fig-1)									
●	S10K-SDQCR/L07-13	13	7	10	125	2	M2. 5x6. 0x3. 6	T8	DC0702
●	S12M-SDQCR/L07-16	16	9	12	150	3			
●	S14N-SDQCR/L07-18	18	10	14	160	3			
●	S16Q-SDQCR/L07-20	20	11	16	180	3			
●	S16Q-SDQCR/L11-20	20	11	16	180	3	M4x8. 8x5. 4	T15	DC11T3
●	S20R-SDQCR/L11-25	25	13	20	200	3			
●	S25R-SDQCR/L11-32	32	17	25	250	4. 5			
高硬度柄 (Y:圖二、Z:圖一) High Hardness Steel With Coolant (Y:Fig-1、Z:Fig-2)									
●	Y10K-SDQCR/L07-13	13	7	10	125	2	M2. 5x6. 0x3. 6	T8	DC0702
●	Y12M-SDQCR/L07-16	16	9	12	150	3			
○	Y14N-SDUCR/L07-18	18	10	14	160	3			
●	Y16N-SDQCR/L07-20	20	11	16	160	3			
●	Y16Q-SDQCR/L07-20	20	11	16	180	3			
○	Y20R-SDQCR/L07-25	25	13	20	200	3			
●	Z10K-SDQCR/L07-13	13	7	10	125	2			
●	Z20R-SDQCR/L07-25	25	13	20	200	3			
●	Y16N-SDQCR/L11-20	20	11	16	160	3	M4x8. 8-5. 4	T15	DC11T3
○	Y16Q-SDQCR/L11-20	20	11	16	180	3			
●	Y20R-SDQCR/L11-25	25	13	20	200	3			
●	Y25R-SDQCR/L11-32	32	17	25	250	4. 5			
●	Y40T-SDQCR/L11-46	46	25	40	300	5			
●	Y50U-SDQCR/L11-56	56	30	50	350	5			
○	Z16N-SDQCR/L11-20	20	11	16	160	3			
○	Z16Q-SDQCR/L11-20	20	11	16	180	3			

●:庫存 In Stock    ○:非標準庫存(請確認交貨期) Non-standard Stock

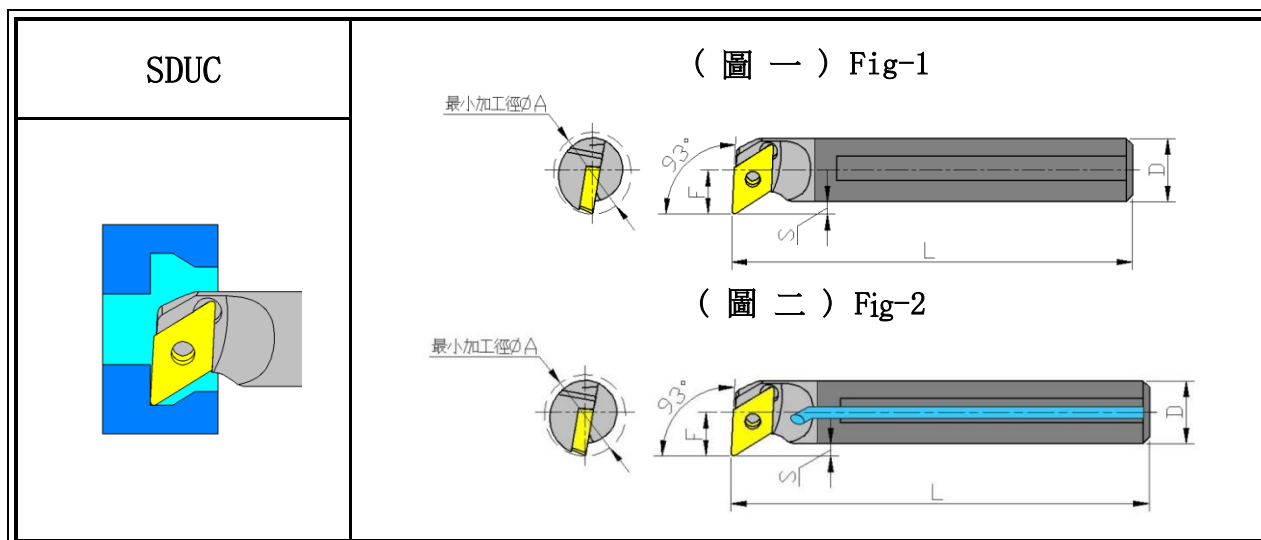
# Zy 內徑車刀 Boring Bars



Stock	型號 Model No.	最小加工徑 A	F	D	L	S	 螺絲 Screw	 板手 Wrench	刀片 Insert
<b>鎢鋼柄 (圖一) Carbide Shank (Fig-1)</b>									
●	C10M-SDUCR/L07-13	13	7	10	150	2	M2.5x6.0x3.6	T8	DC0702
●	C12M-SDUCR/L07-16	16	9	12	150	3			
●	C12Q-SDUCR/L07-16	16	9	12	180	3			
●	C14M-SDUCR/L07-18	18	10	14	150	3			
●	C16M-SDUCR/L07-20	20	11	16	150	3			
●	C16R-SDUCR/L07-20	20	11	16	200	3			
●	C20R-SDUCR/L07-25	25	13	20	200	3			
●	C16M-SDUCR/L11-20	20	11	16	150	3	M4x8.8x5.4	T15	DC11T3
●	C16R-SDUCR/L11-20	20	11	16	200	3			
●	C20R-SDUCR/L11-23	23	12.5	20	200	2.5			
●	C20S-SDUCR/L11-23	23	12.5	20	250	2.5			
●	C25R-SDUCR/L11-32	32	17	25	200	4.5			
●	C25S-SDUCR/L11-32	32	17	25	250	4.5			
○	C32S-SDUCR/L11-40	40	20	32	250	4			
<b>鎢鋼柄 + 水孔 (圖二) Carbide Shank With Coolant (Fig-2)</b>									
●	E10M-SDUCR/L07-13	13	7	10	150	2	M2.5x6.0x3.6	T8	DC0702
●	E12M-SDUCR/L07-16	16	9	12	150	3			
●	E12Q-SDUCR/L07-16	16	9	12	180	3			
●	E14M-SDUCR/L07-18	18	10	14	150	3			
●	E14Q-SDUCR/L07-18	18	10	14	180	3			

●	E16M-SDUCR/L07-20	20	11	16	150	3			
●	E16R-SDUCR/L07-20	20	11	16	200	3			
●	E20R-SDUCR/L07-25	25	13	20	200	3			
●	E16M-SDUCR/L11-20	20	11	16	150	3	M4x8. 8x5. 4	T15	DC11T3
●	E16R-SDUCR/L11-20	20	11	16	200	3			
●	E20R-SDUCR/L11-23	23	12.5	20	200	2.5			
●	E20S-SDUCR/L11-23	23	12.5	20	250	2.5			
●	E25R-SDUCR/L11-32	32	17	25	200	4.5			
●	E25S-SDUCR/L11-32	32	17	25	250	4.5			
○	E32S-SDUCR/L11-40	40	20	32	250	4			
合金鋼柄 (圖一) Alloy Steel (Fig-1)									
●	S10K-SDUCR/L07-13	13	7	10	125	2	M2. 5x6. 0x3. 4	T8	DC0702
●	S12M-SDUCR/L07-16	16	9	12	150	3			
●	S14N-SDUCR/L07-18	18	10	14	160	3			
●	S16Q-SDUCR/L07-20	20	11	16	180	3			
●	S20R-SDUCR/L07-25	25	13	20	200	3			
●	S16Q-SDUCR/L11-20	20	11	16	180	3	M4x8. 8x5. 4	T15	DC11T3
●	S20R-SDUCR/L11-25	25	13	20	200	3			
●	S25S-SDUCR/L11-32	32	17	25	250	4.5			
高硬度柄 (Y:圖二、Z:圖一) High Hardness Steel With Coolant (Y:Fig-1、Z:Fig-2)									
●	Y10K-SDUCR/L07-13	13	7	10	125	2	M2. 5x6. 0x3. 6	T8	DC0702
●	Y12M-SDUCR/L07-16	16	9	12	150	3			
○	Y14N-SDUCR/L07-18	18	10	14	160	3			
●	Y16N-SDUCR/L07-20	20	11	16	160	3			
○	Y16Q-SDUCR/L07-20	20	11	16	180	3			
●	Z10H-SDUCR/L07-13	13	7	10	125	2			
○	Z12M-SDUCR/L07-16	16	9	12	150	3			
●	Z16Q-SDUCR/L07-20	20	11	16	180	3			
●	Y16N-SDUCR/L11-20	20	11	16	160	3	M4x8. 8x5. 4	T15	DC11T3
●	Y16Q-SDUCR/L11-20	20	11	16	180	3			
●	Y20R-SDUCR/L11-23	23	12.5	20	200	2.5			
○	Y20S-SDUCR/L11-23	23	12.5	20	250	2.5			
●	Y25R-SDUCR/L11-32	32	17	25	200	4.5			
●	Y32S-SDUCR/L11-37	37	20	32	250	4			
●	Y40T-SDUCR/L11-46	46	25	40	300	5			
●	Y50U-SDUCR/L11-56	56	30	50	350	5			
●	Z16M-SDUCR/L11-20	20	11	16	150	3			
●	Z20R-SDUCR/L11-23	23	12.5	20	200	2.5			
●	Z25R-SDUCR/L11-32	32	17	25	200	4.5			

# Zy 內徑車刀 Boring Bars

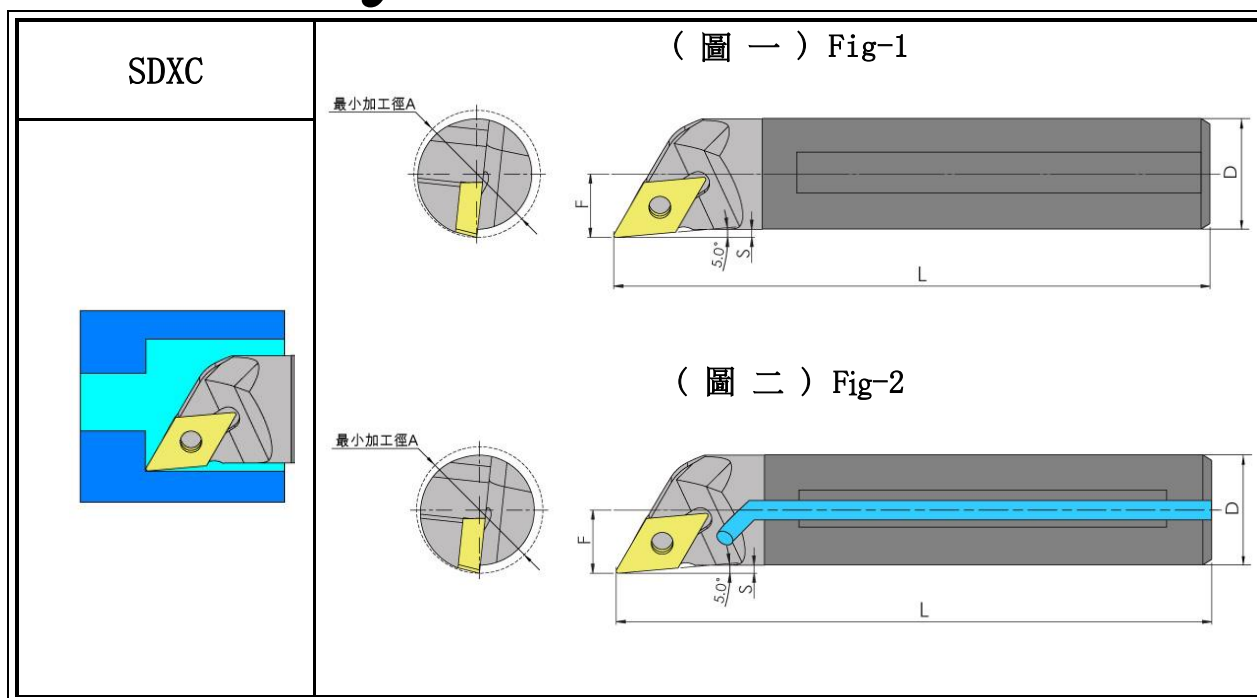

Stock	型號 Model No.	最小加工徑 A	F	D	L	螺絲 Screw	板手 Wrench	刀片 Insert
鎢鋼柄 (圖一) Carbide Shank (Fig-1)								
●	C08K-SDXCR/L07-10	10	5	8	125	M2. 5x6. 0x3. 6	T8	DC0702
●	C10M-SDXCR/L07-12	12	6	10	150			
●	C12M-SDXCR/L07-14	14	7	12	150			
●	C14M-SDXCR/L07-16	16	8	14	150			
●	C16M-SDXCR/L07-18	18	9	16	150			
●	C16R-SDXCR/L07-18	18	9	16	200			
●	C16M-SDXCR/L11-18	18	9	16	200	M4x8. 8x5. 4	T15	DC11T3
●	C20R-SDXCR/L11-25	25	11. 5	20	200			
●	C20S-SDXCR/L11-25	25	11. 5	20	250			
○	C25R-SDXCR/L11-32	32	14	25	200			
○	C25S-SDXCR/L11-32	32	14	25	250			
鎢鋼柄 + 水孔 (圖二) Carbide Shank With Coolant (Fig-2)								
●	E08K-SDXCR/L07-10	10	5	8	125	M2. 5x6. 0x3. 6	T8	DC0702
●	E10M-SDXCR/L07-12	12	6	10	150			
●	E12M-SDXCR/L07-14	14	7	12	150			
●	E16M-SDXCR/L07-18	18	9	16	150			
●	E16R-SDXCR/L07-18	18	9	16	200			

合金鋼柄 (圖一) Alloy Steel (Fig-1)								
●	S08K-SDXCR/L07-10	10	5	8	125	M2. 5x6. 0x3. 6	T8	DC0702
●	S10K-SDXCR/L07-12	12	6	10	125			
●	S12M-SDXCR/L07-14	14	7	12	150			
●	S16Q-SDXCR/L07-18	18	9	16	180			
●	S16Q-SDXCR/L11-18	18	9	16	180	M4x8. 8x5. 4	T15	DC11T3
●	S20R-SDXCR/L11-25	25	11. 5	20	250			
○	S25R-SDXCR/L11-32	32	14	25	200			
高硬度柄 (Y:圖二、Z:圖一) High Hardness Steel With Coolant (Y:Fig-1、Z:Fig-2)								
●	Y12M-SDXCR/L07-14	14	7	12	150	M2. 5x6. 0x3. 6	T8	DC0702
●	Y16N-SDXCR/L07-18	18	9	16	180			
●	Z25R-SDXCR/L11-28	28	14	25	250	M4x8. 8x5. 4	T15	DC11T3

●:庫存 In Stock    ○:非標準庫存(請確認交貨期) Non-standard Stock



# Zy 內徑車刀 Boring Bars

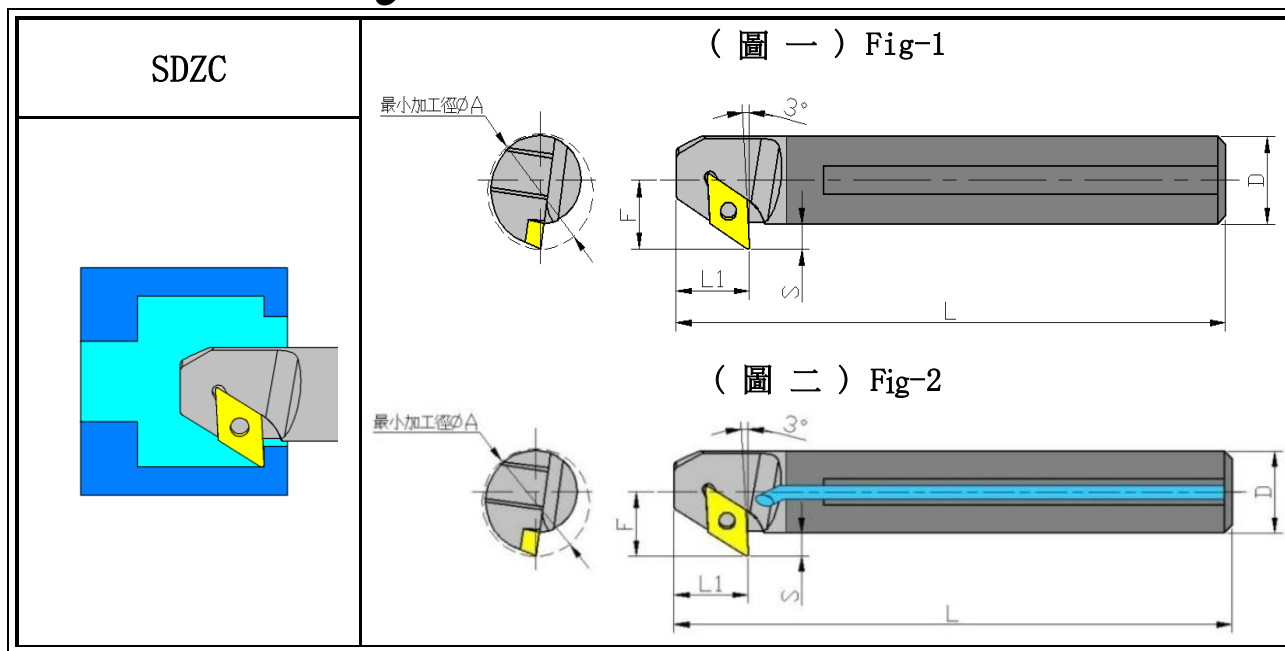

Stock	型號 Model No.	最小加工徑 A	F	D	L	S	螺絲 Screw	扳手 Wrench	刀片 Insert
鎢鋼柄 (圖一) Carbide Shank (Fig-1)									
●	C10M-SDZCR/L07-15	15	8.5	10	150	3.5	M2.5x6.0x3.6	T8	DC0702
●	C12M-SDZCR/L07-17	17	10.5	12	150	4.5			
●	C12Q-SDZCR/L07-17	17	10.5	12	180	4.5			
●	C16M-SDZCR/L07-21	21	12.5	16	150	4.5			
●	C16R-SDZCR/L07-21	21	12.5	16	200	4.5			
○	C20R-SDZCR/L07-26	26	15.5	20	200	5.5	M4x8.8x5.4	T15	DC11T3
●	C20R-SDZCR/L11-26	26	15.5	20	200	5.5			
○	C20S-SDZCR/L11-26	26	15.5	20	250	5.5			
○	C25R-SDZCR/L11-33	33	18	25	200	5.5			
○	C25S-SDZCR/L11-33	33	18	25	250	5.5			
○	C32S-SDZCR/L11-40	40	23	32	250	7			
鎢鋼柄 + 水孔 (圖二) Carbide Shank With Coolant (Fig-2)									
●	E10M-SDZCR/L07-15	15	8.5	10	150	3.5	M2.5x6.0x3.6	T8	DC0702
●	E12M-SDZCR/L07-17	17	10.5	12	150	4.5			
●	E16M-SDZCR/L07-21	21	12.5	16	150	4.5			
●	E16R-SDZCR/L07-21	21	12.5	16	200	4.5			
●	E20R-SDZCR/L11-26	26	15.5	20	200	5.5	M4x8.8x5.4	T15	DC11T3
○	E25R-SDZCR/L11-33	33	18	25	200	5.5			

○	E32S-SDZCR/L11-40	40	21.5	32	250	5.5			
<b>合金鋼柄 (圖一) Alloy Steel (Fig-1)</b>									
●	S10K-SDZCR/L07-15	15	8.5	10	125	3.5	M2.5x6.0x3.6	T8	DC0702
●	S12M-SDZCR/L07-17	17	10.5	12	150	4.5			
●	S16Q-SDZCR/L07-21	21	12.5	16	180	4.5			
●	S20R-SDZCR/L07-26	26	15.5	20	200	5.5			
●	S20R-SDZCR/L11-26	26	15.5	20	200	5.5	M4x8.8x5.4	T15	DC11T3
○	S25R-SDZCR/L11-33	33	18	25	200	5.5			
<b>高硬度柄 (Y:圖二、Z:圖一) High Hardness Steel With Coolant (Y:Fig-1、Z:Fig-2)</b>									
●	Y12M-SDZCR/L07-17	17	10.5	12	150	4.5	M2.5x6.0x3.6	T8	DC0702
●	Y16N-SDZCR/L07-21	21	12.5	16	160	4.5			
●	Y16Q-SDZCR/L07-21	21	12.5	16	180	4.5			
○	Z16R-SDZCR/L07-21	21	12.5	16	200	4.5			
●	Y20R-SDZCR/L11-26	26	15.5	20	200	5.5	M4x8.8x5.4	T15	DC11T3
●	Y25R-SDZCR/L11-33	33	18	25	200	5.5			

●:庫存 In Stock    ○:非標準庫存(請確認交貨期) Non-standard Stock

# Zy 內徑車刀 Boring Bars

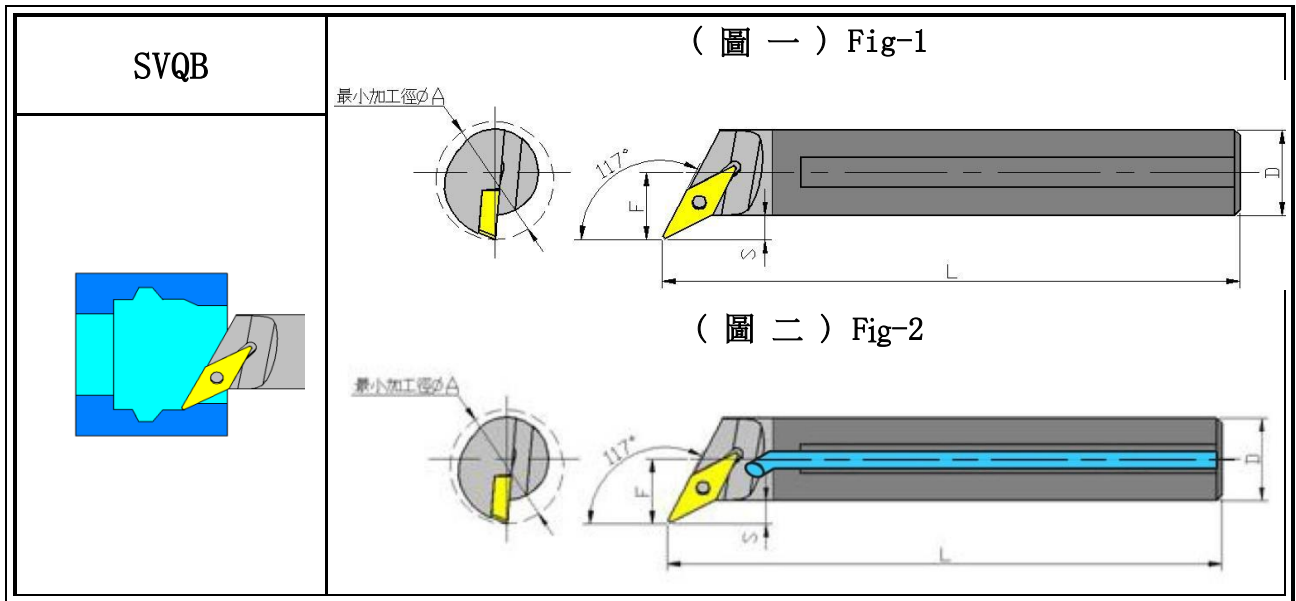

Stock	型號 Model No.	最小加工徑 A	F	D	L	螺絲 Screw	板手 Wrench	刀片 Insert
鎢鋼柄 (圖一) Carbide Shank (Fig-1)								
●	C12M-SVQBR/L11-18	18	11	12	150	M2.5x6.0x3.6	T8	VB1103
●	C16M-SVQBR/L11-22	22	12.5	16	150			
合金鋼柄 (圖一) Alloy Steel (Fig-1)								
●	S12M-SVQBR/L11-18	18	11	12	150	M2.5x6.0x3.6	T8	VB1103
●	S16Q-SVQBR/L11-22	22	12.5	16	180			
●	S20R-SVQCR/L11-25	25	14	20	200			
高硬度柄 (Y:圖二、Z:圖一) High Hardness Steel With Coolant (Y:Fig-1、Z:Fig-2)								
●	Y40T-SVQBR/L16-47	47	25.5	12	300	M3.5x11.4x5.7	T15	VB1604

●:庫存 In Stock    ○:非標準庫存(請確認交貨期) Non-standard Stock

# Zy 內徑車刀 Boring Bars

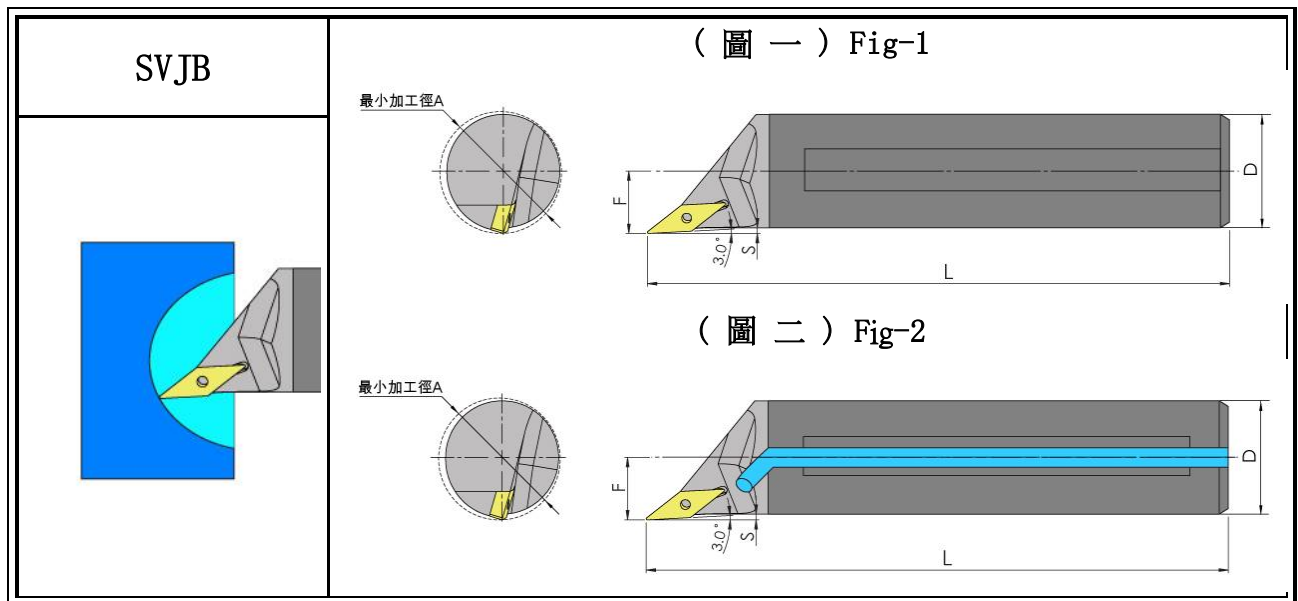

Stock	型號 Model No.	最小加工徑 A	F	D	L	螺絲 Screw	扳手 Wrench	刀片 Insert
鎢鋼柄 (圖一) Carbide Shank (Fig-1)								
●	C10M-SVJBR/L11-12	12	6	10	150	M2. 5x6. 0x3. 6	T8	VB1103
●	C12M-SVJBR/L11-14	14	7	12	150			
●	C16R-SVJBR/L11-18	18	9	16	200			
○	C20R-SVJBR/L11-22	22	11	20	200			
合金鋼柄 (圖一) Alloy Steel (Fig-1)								
●	S10K-SVJBR/L11-12	12	6	10	125	M2. 5x6. 0x3. 6	T8	VB1103
●	S12M-SVJBR/L11-14	14	7	12	150			
●	S16Q-SVJBR/L11-18	18	9	16	180			
●	S20R-SVJBR/L11-22	22	11	20	200			
高硬度柄 (Y:圖二、Z:圖一) High Hardness Steel With Coolant (Y:Fig-1、Z:Fig-2)								
●	Y40T-SVJBR/L16-47	47	25. 5	12	300	M3. 5x11. 4x5. 7	T15	VB1604

●:庫存 In Stock    ○:非標準庫存(請確認交貨期) Non-standard Stock

# Zy 內徑車刀 Boring Bars

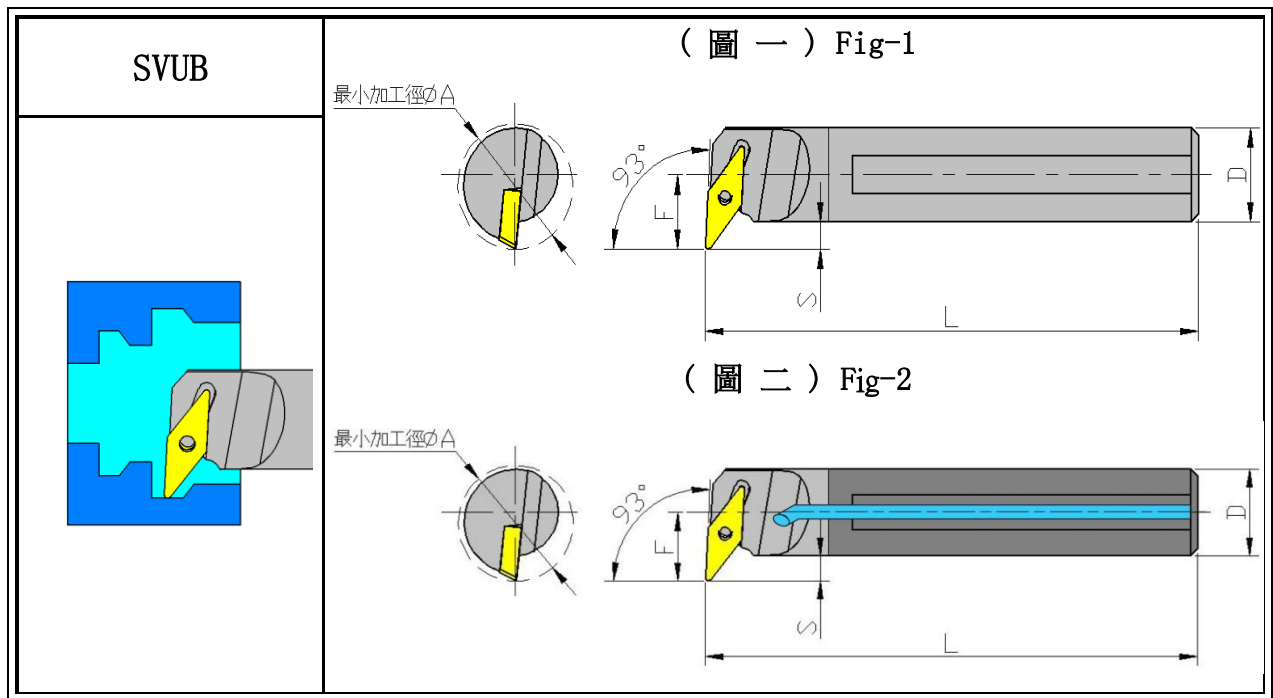

Stock	型號 Model No.	最小加工徑 A	F	D	L	S	螺絲 Screw	扳手 Wrench	刀片 Insert
錫鋼柄 (圖一) Carbide Shank (Fig-1)									
●	C16M-SVUBR/L11-22	22	12.5	16	150	4.5	M2.5x6.0x3.6	T8	VB1103
●	C16R-SVUBR/L11-22	22	12.5	16	200	4.5			
●	C20R-SVUBR/L11-27	27	15	20	200	5			
錫鋼柄 + 水孔 (圖二) Carbide Shank With Coolant (Fig-2)									
●	E16R-SVUBR/L11-22	22	12.5	16	200	4.5	M2.5x6.0x3.6	T8	VB1103
●	E20R-SVUBR/L11-27	27	15	20	200	5			
合金鋼柄 (圖一) Alloy Steel (Fig-1)									
●	S16Q-SVUBR/L11-22	22	12.5	16	180	4.5	M2.5x6.0x3.6	T8	VB1103
●	S20R-SVUBR/L11-27	27	15	20	200	5			
●	S20R-SVUBR/L16-31	31	19	20	200	9	M3.5x12.0x5.4	T15	VB1604
高硬度柄 (Y:圖二、Z:圖一) High Hardness Steel With Coolant (Y:Fig-2、Z:Fig-1)									
●	Y40T-SVUBR/L16-48	27	12.5	16	300	7	M3.5x11.4x5.7	T8	VB1604

●:庫存 In Stock    ○:非標準庫存(請確認交貨期) Non-standard Stock

# Zy 內徑車刀 Boring Bars

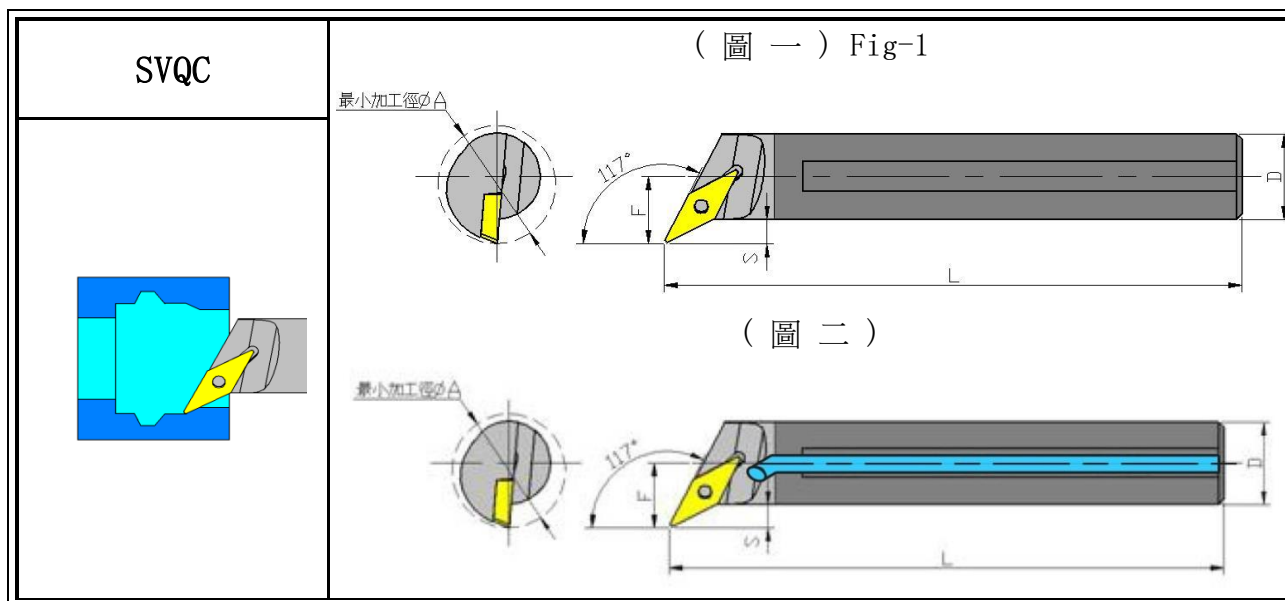

Stock	型號 Model No.	最小加工徑 A	F	D	L	螺絲 Screw	扳手 Wrench	刀片 Insert
鎢鋼柄 (圖一) Carbide Shank (Fig-1)								
●	C12M-SVQCR/L11-18	18	11	12	150	M2.5x6.0x3.6	T8	VC1103
●	C16M-SVQCR/L11-22	22	12.5	16	150			
●	C16R-SVQCR/L11-22	22	12.5	16	200			
○	C20R-SVQCR/L11-25	25	14	20	200	M3.5x12.0x5.4-67	T15	VC1604
●	C25R-SVQCR/L16-32	32	17	25	200			
○	C32S-SVQCR/L16-37	37	20	32	250			
鎢鋼柄 + 水孔 (圖二) Carbide Shank With Coolant (Fig-2)								
●	E16M-SVQCR/L11-22	22	12.5	16	150	M2.5x6.0x3.6	T8	VC1103
●	E16R-SVQCR/L11-22	22	12.5	16	200			
○	E20R-SVQCR/L11-25	25	13	20	200			
○	E25R-SVQCR/L16-32	32	17	25	200	M3.5x11.4x5.7	T15	VC1604
合金鋼柄 (圖一) Alloy Steel (Fig-1)								
●	S12M-SVQCR/L11-18	18	11	12	150	M2.5x6.0x3.6	T8	VC1103
●	S16Q-SVQC/LR11-22	22	12.5	16	180			
●	S20R-SVQCR/L11-25	25	14	20	200			
高硬度柄 (Y:圖二、Z:圖一) High Hardness Steel With Coolant (Y:Fig-2、Z:Fig-1)								
●	Y40T-SVQCR/L16-47	47	25.5	25	300	M3.5x11.4x5.7	T15	VC1604
●	Z25R-SVQCR/L16-32	32	17	25	200			

# Zy 內徑車刀 Boring Bars

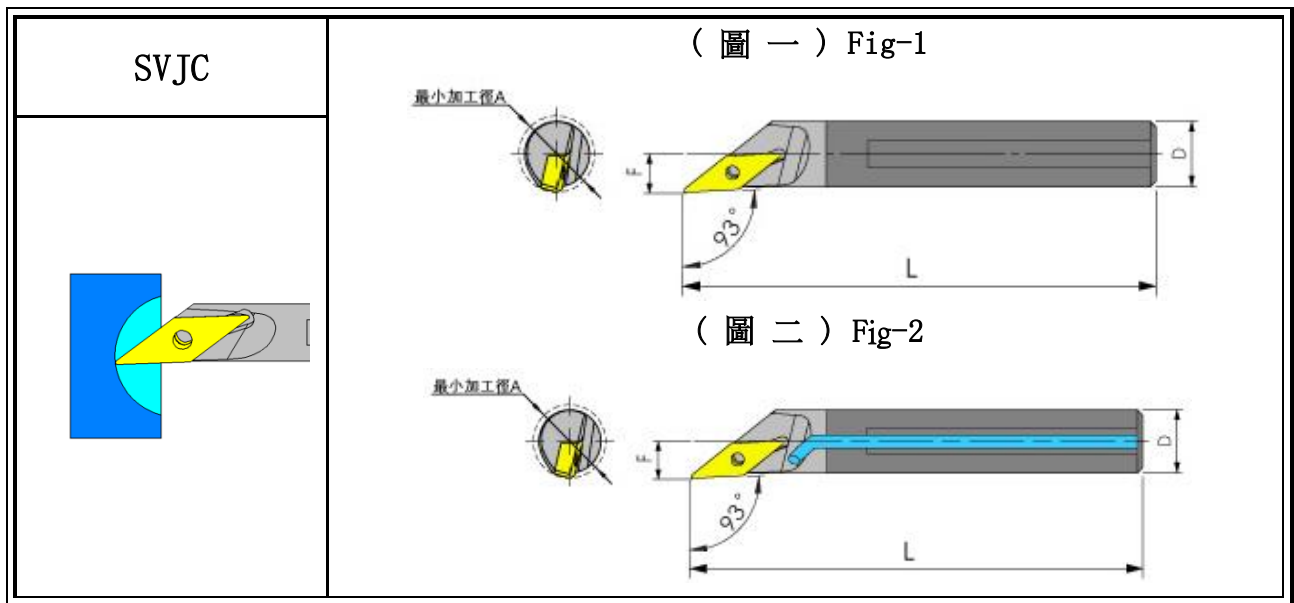

Stock	型號 Model No.	最小加工徑 A	F	D	L	螺絲 Screw	板手 Wrench	刀片 Insert
鎢鋼柄 (圖一) Carbide Shank (Fig-1)								
●	C06J-SVJCR/L08-085	8.5	3.25	6	110	M2x5.0x2.6	T6	VC0802
●	C08K-SVJCR/L08-10	10	5	8	125			
●	C10M-SVJCR/L08-12	12	6	10	150			
●	C12M-SVJCR/L08-14	14	7	12	150			
●	C10M-SVJCR/L11-12	12	6	10	150	M2.5x6.0x3.6	T8	VC1103
●	C12M-SVJCR/L11-14	14	7	12	150			
●	C12Q-SVJCR/L11-14	14	7	12	180			
●	C16M-SVJCR/L11-18	18	9	16	150			
●	C16R-SVJCR/L11-18	18	9	16	200			
●	C20R-SVJCR/L11-22	22	11	20	200			
●	C20S-SVJCR/L11-22	22	11	20	250	M3.5x12.0x5.4-67	T15	VC1604
●	C16M-SVJCR/L16-18	18	9	16	150			
●	C16R-SVJCR/L16-18	18	9	16	200			
○	C20R-SVJCR/L16-23	23	11.5	20	200			
○	C25R-SVJCR/L16-28	28	14	25	200			
○	C32S-SVJCR/L16-35	35	17.5	32	250			
鎢鋼柄 + 水孔 (圖二) Carbide Shank With Coolant (Fig-2)								
●	E06J-SVJCR/L08-085	8.5	3.25	6	110	M2x5.0x2.6	T6	VC0802



●	E08K-SVJCR/L08-10	10	5	8	125			
●	E10M-SVJCR/L08-12	12	6	10	150			
○	E12M-SVJCR/L08-14	14	7	12	150			
●	E10M-SVJCR/L11-12	12	6	10	150	M2. 5x6. 0x3. 6	T8	VC1103
●	E12M-SVJCR/L11-14	14	7	12	150			
●	E12Q-SVJCR/L11-14	14	7	12	180			
●	E16M-SVJCR/L11-18	18	9	16	150			
●	E16R-SVJCR/L11-18	18	9	16	200			
●	E20R-SVJCR/L11-22	22	11	20	200			
●	E20S-SVJCR/L11-22	22	11	20	250			
●	E16M-SVJCR/L16-18	18	9	16	150	M3. 5x12. 0x5. 4	T15	VC1604
○	E16R-SVJCR/L16-18	18	9	16	200			
○	E20R-SVJCR/L16-23	23	11.5	20	200			
○	E25R-SVJCR/L16-28	28	14	25	200			
<b>合金鋼柄 (圖一) Alloy Steel (Fig-1)</b>								
●	S08K-SVJCR/L08-10	10	5	8	125	M2x5. 0x2. 6	T6	VC0802
●	S10K-SVJCR/L08-12	12	6	10	125			
●	S12M-SVJCR/L08-14	14	7	12	150			
●	S10K-SVJCR/L11-12	12	6	10	125	M2. 5x6. 0x3. 6	T8	VC1103
●	S12M-SVJCR/L11-14	14	7	12	150			
●	S16Q-SVJCR/L11-18	18	9	16	180			
●	S20R-SVJCR/L11-22	22	11	20	200			
●	S16Q-SVJCR/L16-18	18	9	16	180	M3. 5x12. 0x5. 4	T15	VC1604
●	S20R-SVJCR/L11-23	23	11.5	20	200			
○	S25R-SVJCR/L16-32	32	14	25	200			
<b>高硬度柄 (Y:圖二、Z:圖一) High Hardness Steel With Coolant (Y:Fig-2、Z:Fig-1)</b>								
●	Y10M-SVJCR/L08-12	12	6	10	150	M2x5. 0x2. 6	T6	VC0802
●	Y12M-SVJCR/L08-14	14	7	12	150			
●	Z08H-SVJCR/L08-10	10	5	8	125			
●	Y10K-SVJCR/L11-12	12	6	10	125	M2. 5x6. 0x3. 6	T8	VC1103
●	Y12M-SVJCR/L11-14	14	7	12	150			
●	Y16Q-SVJCR/L11-18	18	9	16	180			
●	Y20R-SVJCR/L11-22	22	11	20	200			
○	Z16Q-SVJCR/L11-18	18	9	16	180			
○	Z20R-SVJCR/L11-22	22	11	20	200			
●	Y16N-SVJCR/L16-18	18	9	16	160			
○	Y20R-SVJCR/L16-23	23	11.5	20	200			
○	Z16N-SVJCR/L16-18	18	9	16	160			
●	Z20R-SVJCR/L16-23	23	11.5	20	200			

# Zy 內徑車刀 Boring Bars

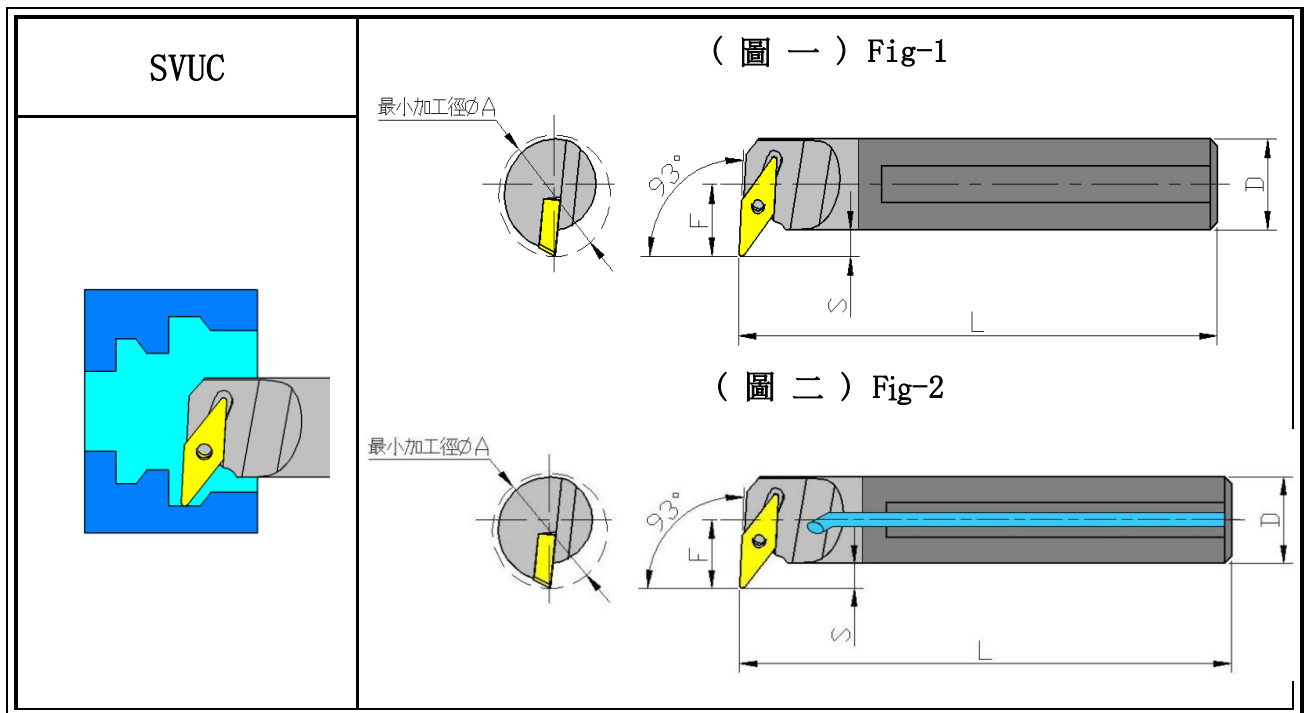

Stock	型號 Model No.	最小加工徑 A	F	D	L	S	螺絲 Screw	扳手 Wrench	刀片 Insert
錫鋼柄 (圖一) Carbide Shank (Fig-1)									
●	C10M-SVUCR/L07-15	15	8.5	10	150	3.5	M2x5.0x2.6	T6	VC0702
●	C12M-SVUCR/L07-15	15	8.5	12	150	2.5			
●	C12M-SVUCR/L08-16	16	9.5	12	150	3.5	M2x5.0x2.6	T6	VC0802
●	C12Q-SVUCR/L08-16	16	9.5	12	180	3.5			
●	C14M-SVUCR/L08-19	19	11	14	150	4			
●	C16M-SVUCR/L11-22	22	12.5	16	180	4.5	M2.5x6.0x3.6	T8	VC1103
●	C16R-SVUCR/L11-22	22	12.5	16	200	4.5			
●	C20R-SVUCR/L11-27	27	15	20	200	5			
○	C20S-SVUCR/L11-27	27	15	20	250	5			
●	C25R-SVUCR/L11-31	35	20	25	200	7.5			
○	C20R-SVUCR/L16-31	31	19	20	200	9	M3.5x12.0x5.4	T15	VC1604
○	C20S-SVUCR/L16-31	31	19	20	250	9			
○	C25R-SVUCR/L16-33	33	18	25	200	5.5			
○	C25S-SVUCR/L16-33	33	18	25	250	5.5			
○	C25R-SVUCR/L16-35	35	20	25	200	7.5			
○	C25S-SVUCR/L16-35	35	20	25	250	7.5			

○	C32S-SVUCR/L16-40	40	22	32	250	6			
<b>鎢鋼柄 + 水孔 (圖二) Carbide Shank With Coolant (Fig-2)</b>									
●	E16R-SVUCR/L11-22	22	12.5	16	200	4.5	M2.5x6.0x3.6	T8	VC1103
●	E20R-SVUCR/L11-27	27	15	20	200	5			
○	E25R-SVUCR/L11-30	30	17	25	250	4.5			
○	E20R-SVUCR/L16-31	31	19	20	200	9	M3.5x12.0x5.4	T15	VC1604
○	E25R-SVUCR/L16-33	33	18	25	200	5.5			
○	E25S-SVUCR/L16-33	33	18	25	250	5.5			
○	E25R-SVUCR/L16-35	35	20	25	200	7.5			
○	E25S-SVUCR/L16-35	35	20	25	250	7.5			
○	E32S-SVUCR/L16-40	40	22	32	250	6			
<b>合金鋼柄 (圖一) Alloy Steel (Fig-1)</b>									
●	S12M-SVUCR/L07-15	15	8.5	12	150	2.5	M2x5.0x2.6	T6	VC0702
●	S12M-SVUCR/L08-16	16	9.5	12	150	3.5	M2x5.0x2.6	T6	VC0802
●	S16Q-SVUCR/L11-22	22	12.5	16	180	4.5	M2.5x6.0x3.6	T8	VC1103
●	S20R-SVUCR/L11-27	27	15	20	200	5			
○	S25R-SVUCR/L16-35	35	20	25	200	7.5	M3.5x12.0x5.4	T15	VC1604
<b>高硬度柄 (Y:圖二、Z:圖一) High Hardness Steel With Coolant (Y:Fig-2、Z:Fig-1)</b>									
●	Y12M-SVUCR/L07-15	15	8.5	12	150	2.5	M2x5.0x2.6	T6	VC0702
●	Y12M-SVUCR/L08-16	16	9.5	12	150	3.5	M2x5.0x2.6	T6	VC0802
●	Y16N-SVUCR/L11-22	22	12.5	16	160	4.5	M2.5x6.0x3.6	T8	VC1103
●	Y20R-SVUCR/L11-27	27	15	20	200	5			
●	Z16Q-SVUCR/L11-22	22	13	16	180	4.5			
●	Z20R-SVUCR/L11-27	27	15	20	200	5			
○	Z25R-SVUCR/L11-31	31	17	25	250	4.5			
●	Y40T-SVUCR/L16-48	48	27	40	300	7	M3.5x12.0x5.4	T15	VC1604
●	Z25R-SVUCR/L16-33	33	18	25	200	5.5			

●:庫存 In Stock    ○:非標準庫存(請確認交貨期) Non-standard Stock

# Zy 內徑車刀 Boring Bars

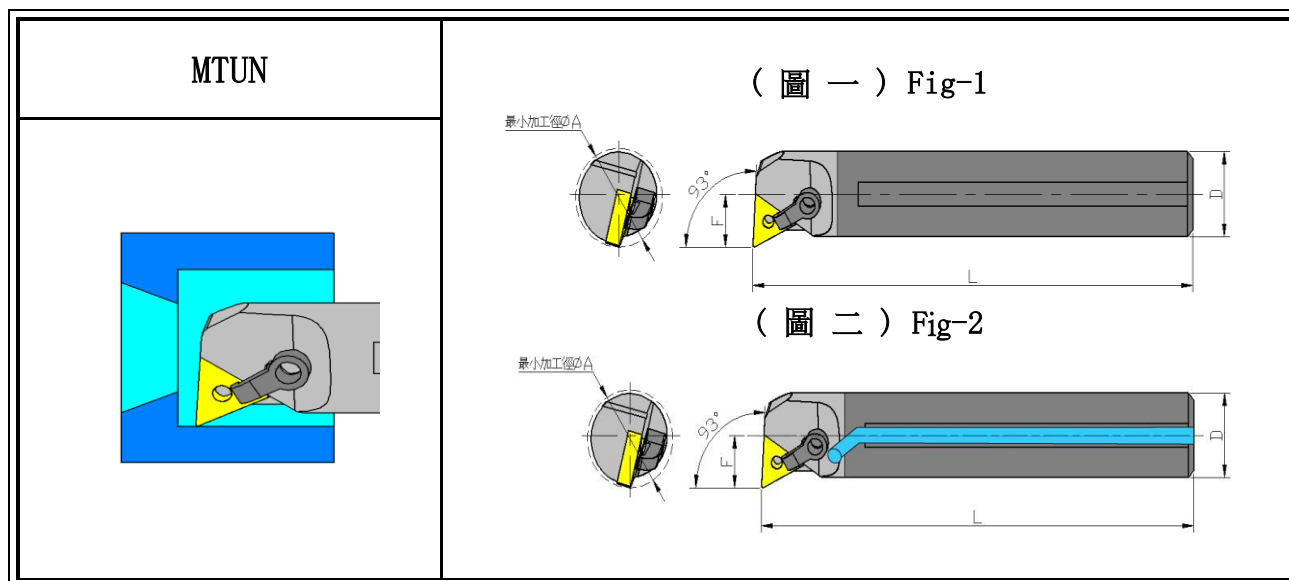

Stock	型號 Model No.	最小加工徑 A	F	D	L	墊片 Shim	雙頭螺絲 Clamp Screw	壓板 Clamp	偏心螺絲 Shim Screw	板手 Wrench
錫鋼柄 (圖一) Carbide Shank (Fig-1)										
●	C16M-MTUNR/L16-22A	22	11.5	16	150		MS518	CP50-12	LCS-510	P2.0
●	C16R-MTUNR/L16-22A	22	11.5	16	200					P2.5
●	C20R-MTUNR/L16-25A	25	13	20	200	-	MS520	CP50-12	LCS-510	P2.0
●	C20S-MTUNR/L16-25A	25	13	20	250					P2.5
●	C25R-MTUNR/L16-32A	32	17	25	200	-	MS620	CP50-22	LCS-510	P2.0
●	C25S-MTUNR/L16-32A	32	17	25	250					P3.0
○	C32S-MTUNR/L16-40A	40	20	32	250	TMS322	MS625	CP50-22	LCS-513	P2.0
○	C40S-MTUNR/L16-50A	50	26	40	250					P3.0
○	C50S-MTUNR/L16-60A	60	31	50	250					
錫鋼柄 + 水孔 (圖二) Carbide Shank With Coolant (Fig-2)										
●	E20R-MTUNR/L16-25A	25	13	20	200	-	MS520	CP50-12	LCS-510	P2.0
●	E20S-MTUNR/L16-25A	25	13	20	250					P2.5
●	E25R-MTUNR/L16-32A	32	17	25	200	-	MS620	CP50-22	LCS-510	P2.0
●	E25S-MTUNR/L16-32A	32	17	25	250					P3.0
○	E32S-MTUNR/L16-40A	40	20	32	250	TMS322	MS625	CP50-22	LCS-513	P2.0 P3.0
合金鋼柄 (圖一) Alloy Steel (Fig-1)										
●	S20R-MTUNR16-22A	22	13	20	200	-	GCS520	CP50-26	LCS-510	P3.0

○	S25R-MTUNR16-32A	32	17	25	200		GCS620	CP50-22	LCS-510	P3.0
<b>高 硬 度 柄 ( Y : 圖 二 、 Z : 圖 一 ) High Hardness Steel With Coolant ( Y : Fig-2 、 Z : Fig-1 )</b>										
○	Y16N-MTUNR/L16-22A	22	11.5	16	160	-	MS518	CP50-12	LCS-510	P2.0 P2.5
●	Y16Q-MTUNR/L16-22A	22	11.5	16	180					
○	Z16N-MTUNR/L16-22A	22	11.5	16	160					
●	Z16Q-MTUNR/L16-22A	22	11.5	16	180					
●	Y20R-MTUNR/L16-25A	25	13	20	200	-	MS520	CP50-12	LCS-510	P2.0 P2.5
●	Z20R-MTUNR/L16-25A	25	13	20	250					
○	Y25R-MTUNR/L16-32A	32	17	25	200	-	MS620	CP50-22	LCS-510	P2.0 P3.0
○	Y25S-MTUNR/L16-32A	32	17	25	250					
●	Z25R-MTUNR/L16-32A	32	17	25	200					
●	Z25S-MTUNR/L16-32A	32	17	25	250					
●	Y40T-MTUNR/L16-47A	47	26	40	300					
●	Y50U-MTUNR/L16-57A	57	31	50	350					
						TMS322	MS625	CP50-22	LCS-513	

●:庫存 In Stock    ○:非標準庫存(請確認交貨期) Non-standard Stock

刀片 Inserts:TN16

# Zy 內徑車刀 Boring Bars

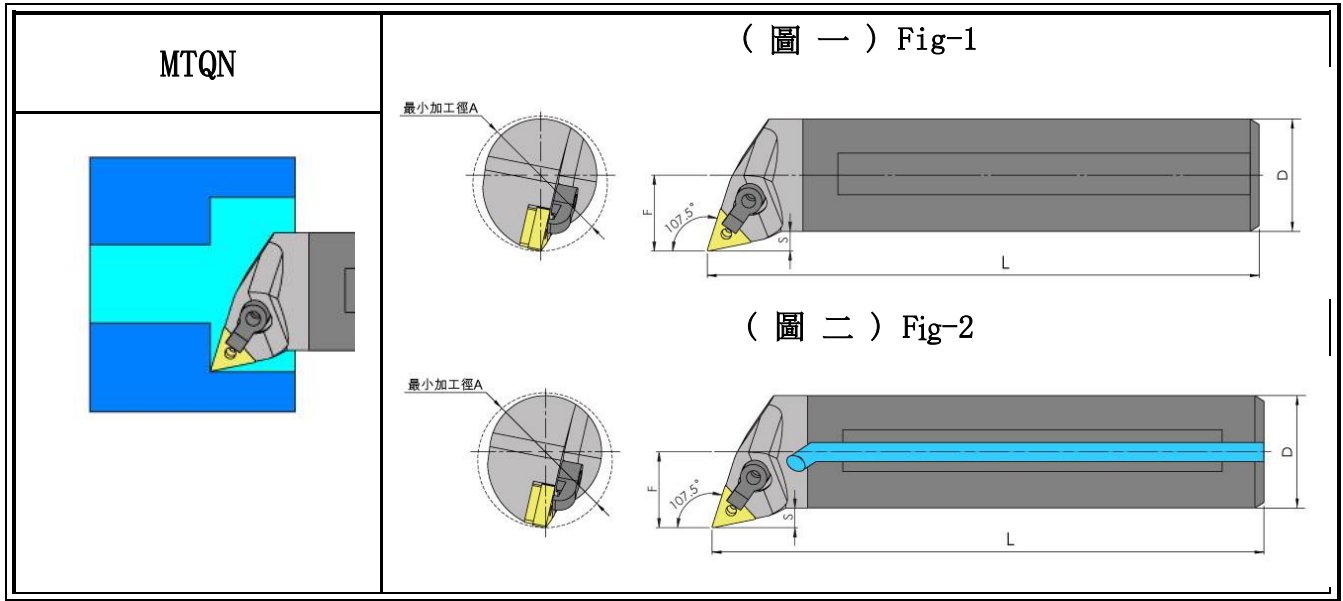

Stock	型號 Model No.	最小加工徑 A	F	D	L	墊片 Shim	雙頭螺絲 Clamp Screw	壓板 Clamp	偏心螺絲 Shim Screw	板手 Wrench
錫鋼柄 (圖一) Carbide Shank (Fig-1)										
○	C20R-MTQNR/L16-25	25	12.5	20	200	-	MS520	CP50-12	LCS510	L2.0 L2.5
○	C25R-MTQNR/L16-32	32	16	25	200	-				
○	C32S-MTQNR/L16-41	41	22.5	32	250	-				
○	C40T-MTQNR/L16-50	50	26.5	40	300	-				
高硬度柄 (Y:圖二、Z:圖一) High Hardness Steel With Coolant (Y:Fig-2、Z:Fig-1)										
●	Y50T-MTQNR/L16-57	57	31	50	300	TMS322	MS625	CP50-22	LCS513	L2.0 L3.0

●:庫存 In Stock    ○:非標準庫存(請確認交貨期) Non-standard Stock

刀片 Inserts:TN1604

# Zy 內徑車刀 Boring Bars

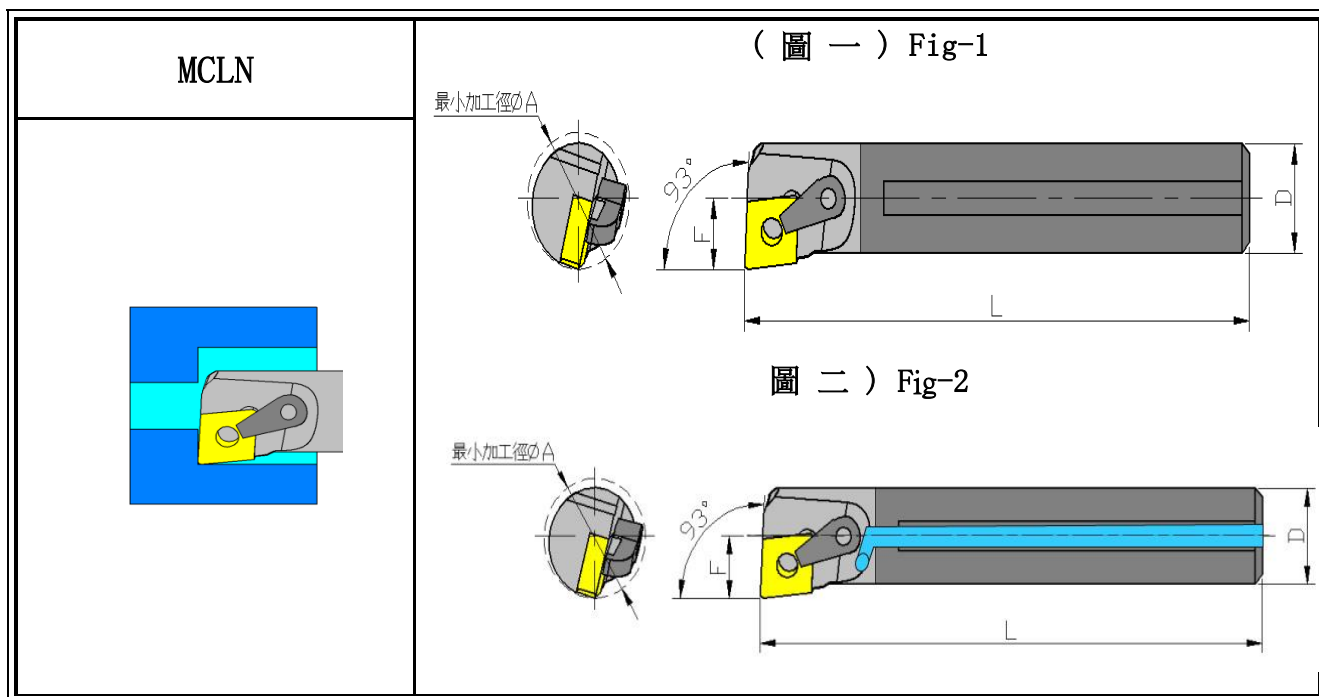

Stock	型號 Model No.	最小加工徑 A	F	D	L	墊片 Shim	雙頭螺絲 Clamp Screw	壓板 Clamp	偏心螺絲 Shim Screw	板手 Wrench
鎢鋼柄 (圖一) Carbide Shank (Fig-1)										
●	C20R-MCLNR/L12-25	25	13	20	200	-	MS520	CP50-12	LCS-511	L2.5
●	C20S-MCLNR/L12-25	25	13	20	250					
●	C25R-MCLNR/L12-32	32	15	25	200	-	MS625	CP50-22	LCS-511	L2.5
○	C25S-MCLNR/L12-32	32	15	25	250					
○	C32S-MCLNR/L12-40	40	20	32	250	CMS432	MS625	CP50-22	LCS-617	L3.0
○	C40S-MCLNR/L12-50	50	25	40	250					
○	C50T-MCLNR/L12-60	60	30	50	300					
鎢鋼柄 + 水孔 (圖二) Carbide Shank With Coolant (Fig-2)										
●	E20R-MCLNR/L12-25	25	13	20	200	-	MS520	CP50-12	LCS-511	L2.5
●	E20S-MCLNR/L12-25	25	13	20	250					
●	E25R-MCLNR/L12-32	32	15	25	200	-	MS625	CP50-22	LCS-511	L2.5
○	E25S-MCLNR/L12-32	32	15	25	250					
○	E32S-MCLNR/L12-40	40	20	32	250	CMS432	MS625	CP50-22	LCS-617	L3.0

●:庫存 In Stock    ○:非標準庫存(請確認交貨期) Non-standard Stock

刀片 Inserts:CN1204



# Zy 內徑車刀 Boring Bars

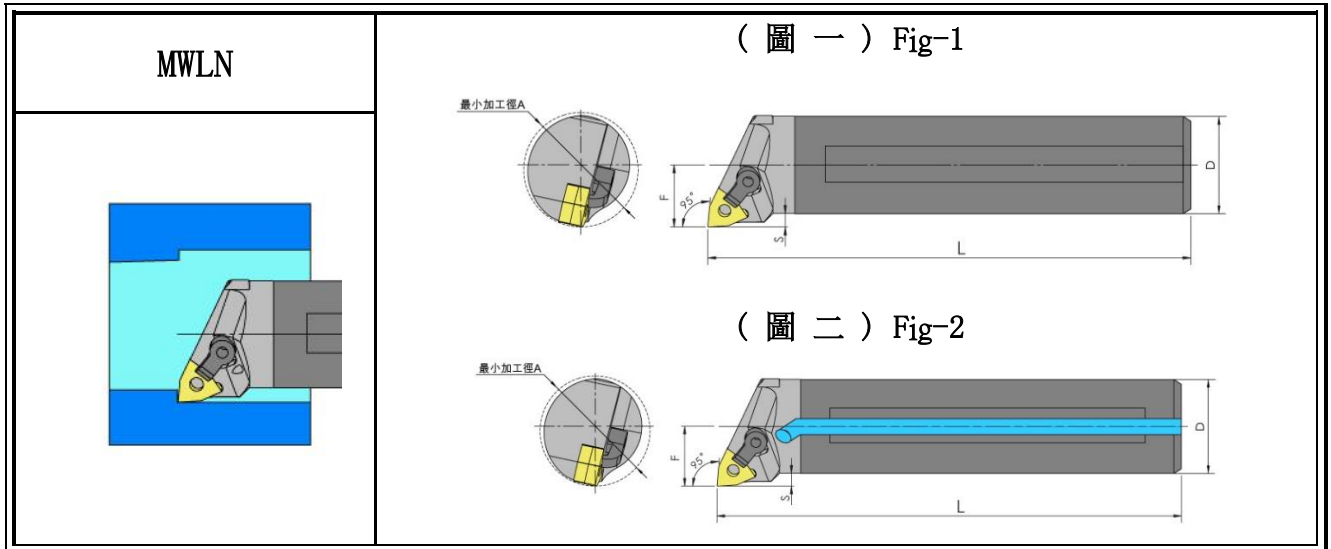

Stock	型號 Model No.	最小加工徑	F	D	L	墊片 Shim	雙頭螺絲 Clamp Screw	壓板 Clamp	偏心螺絲 Shim Screw	板手 Wrench		
鎢鋼柄 (圖一) Carbide Shank (Fig-1)												
●	C20R-MWLN/L08-25	25	13	20	200	-	MS520	CP50-12	LCS-511	P2.0 P2.5		
○	C25R-MWLN/L08-32	32	17	25	200	-	MS625	CP50-22	LCS-511	P2.5 P3.0		
鎢鋼柄 + 水孔 (圖二) Carbide Shank With Coolant (Fig-2)												
○	E20R-MWLN/L08-25	25	13	20	200	-	MS520	CP50-12	LCS-511	P2.0 P2.5		
○	E25R-MWLN/L08-32	32	17	25	200	-	MS625	CP50-22	LCS-511	P2.5 P3.0		
合金鋼柄 (圖一) Alloy Steel (Fig-1)												
●	S20R-MWLN/L08-25	25	13	20	200	-	MS520	CP50-12	LCS-511	P2.0 P2.5		
高硬度柄 (Y:圖二、Z:圖一) High Hardness Steel With Coolant (Y:Fig-2、Z:Fig-1)												
●	Y20R-MWLN/L08-25	25	13	20	200	-	MS520	CP50-12	LCS-511	P2.0 P2.5		
●	Y25R-MWLN/L08-32	32	17	25	200	-	MS625	CP50-22	LCS-511	P2.5 P3.0		
○	Y32S-MWLN/L08-40	40	20	32	250	WMS432			MS625		CP50-22	LCS-511
●	Y40T-MWLN/L08-47	47	25.5	40	300							LCS-617
●	Y50U-MWLN/L08-57	57	30.5	50	350							LCS-617

●:庫存 In Stock    ○:非標準庫存(請確認交貨期) Non-standard Stock

刀片 Inserts:WN0804



# 套筒系列



錳鋼車刀

搭配套筒

組立圖

CNC車刀專用套筒

# Zy 內徑車刀套筒 ZNC Sleeve

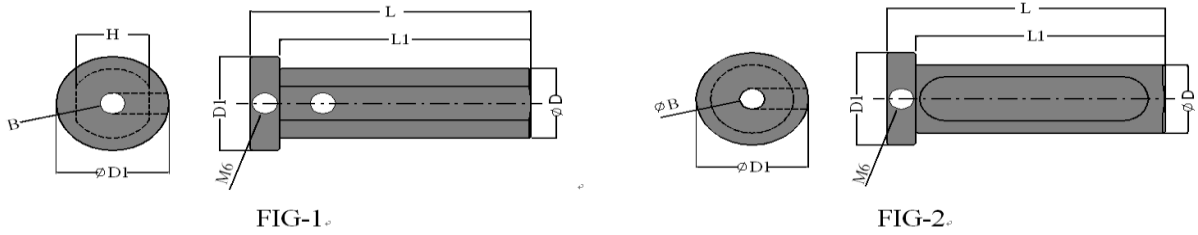



Stock	型號 Model No.	B	D	L	L1	D1	H	M	圖 Fig
○	ZNC20-08	8	20	67	60	27	17.5	M6	FIG-1
○	ZNC20-10	10							FIG-1
○	ZNC20-12	12							FIG-1
○	ZNC20-16	16					55	13	FIG-2
○	ZNC25-06	6	25	64	58	35	23.5	M6	FIG-1
○	ZNC25-08	8							FIG-1
○	ZNC25-10	10							FIG-1
○	ZNC25-12	12							FIG-1
○	ZNC25-16	16					51	12	FIG-2
○	ZNC25-20	20							FIG-2
○	ZNC32-06	6	32	85	70	38	29.5	M6	FIG-1
○	ZNC32-08	8							FIG-1
○	ZNC32-10	10							FIG-1
○	ZNC32-12	12							FIG-1
○	ZNC32-16	16		100	85	77	14	FIG-1	
○	ZNC32-18	18						FIG-2	
○	ZNC32-20	20						FIG-2	
○	ZNC32-25	25						FIG-2	
○	ZNC40-06	6	40	100	85	46	38	M8	FIG-1
○	ZNC40-08	8							FIG-1
○	ZNC40-10	10							FIG-1
○	ZNC40-12	12							FIG-1
○	ZNC40-16	16							FIG-1
○	ZNC40-18	18					77	14	FIG-2
○	ZNC40-20	20							FIG-2
○	ZNC40-25	25							FIG-2
○	ZNC40-32	32							FIG-2

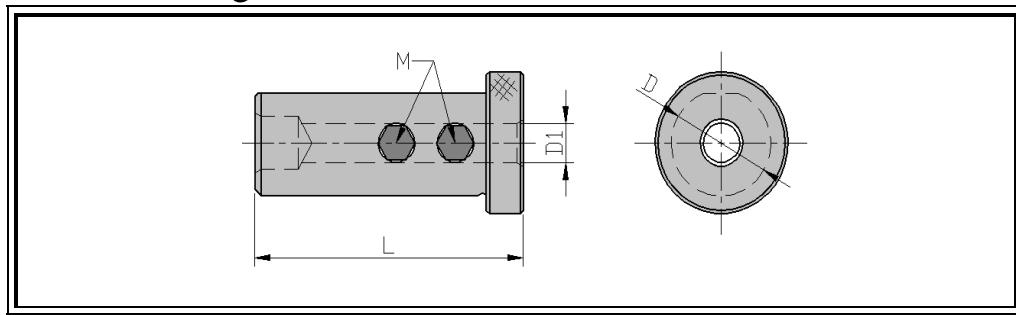

●:庫存 In Stock    ○:非標準庫存(請確認交貨期) Non-standard Stock    ▲:訂購套筒請註明使用機台

# Zy 內徑車刀套筒 Sleeve

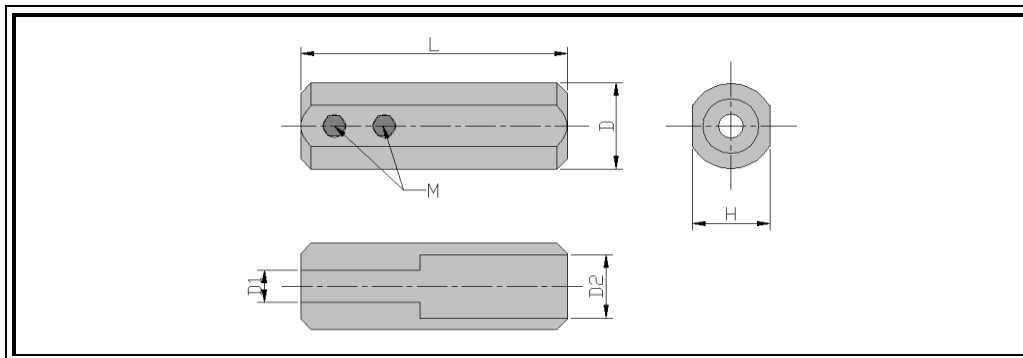

Stock	型號 Model No.	D	D1	L	 螺絲 Screw	 板手 Wrench
●	SH-0416-60	16	4	60	SETM4x4L	L2.0
●	SH-0516-60	16	5	60	SETM5x5L	L2.5
●	SH-0616-60	16	6	60	SETMx4L	L3.0
●	SH-0716-60	16	7	60	SETM6x4L	L3.0





Stock	型號 Model No.	D	D1	D2	H	L	 螺絲 Clamp Screw	 板手 Wrench
●	SH-0316-100	16	3	6	14	100	SETM4x5L	L2.0
●	SH-0416-100	16	4	5	14	100	SETM4x4L	L2.0
●	SH-0516-100	16	5	6	14	100	SETM5x5L	L2.5
●	SH-0616-100	16	6	7	14	100	SETM6x4L	L3.0
●	SH-0716-100	16	7	8	14	100	SETM6x4L	L3.0
●	SH-0816-100	16	8	9	15	100	SETM6x5L	L3.0
●	SH-0820-100	20	8	9	18.5	100	SETM6x5L	L3.0
●	SH-1020-100	20	10	11	18.5	100	SETM6x4L	L3.0

●:庫存 In Stock    ○:非標準庫存(請確認交貨期) Non-standard Stock

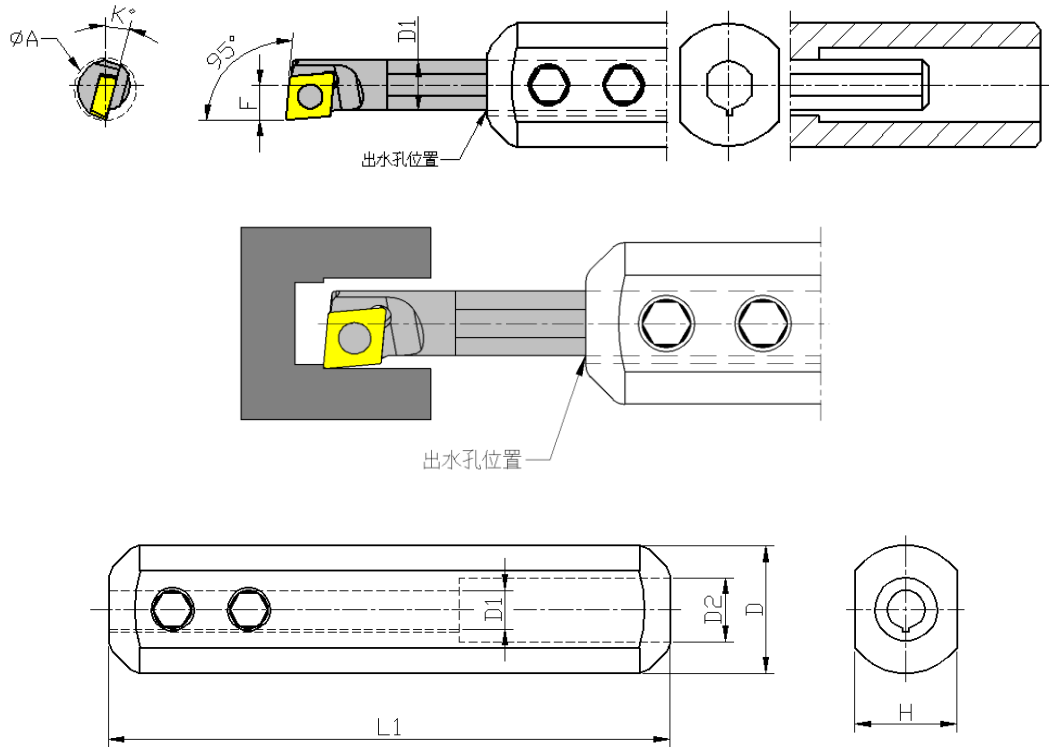
# Zy 內徑車刀水孔套筒 Sleeve With Coolant





Stock	型號 Model No.	D	D1	D2	H	L1	 螺絲 Screw	 板手 Wrench
●	SHE-0416-100	16	4	5	14	100	SETM4x4L	L2.0
●	SHE-0516-100	16	5	6	14	100	SETM5x5L	L2.5
●	SHE-0616-100	16	6	7	14	100	SETM6x4L	L3.0
●	SHE-0716-100	16	7	8	14	100	SETM6x4L	L3.0
●	SHE-0816-100	16	8	9	15	100	SETM6x5L	L3.0
●	SHE-0820-100	20	8	9	18.5	100	SETM6x5L	L3.0
●	SHE-1020-100	20	10	11	18.5	100	SETM6x4L	L3.0

●:庫存 In Stock    ○:非標準庫存(請確認交貨期) Non-standard Stock

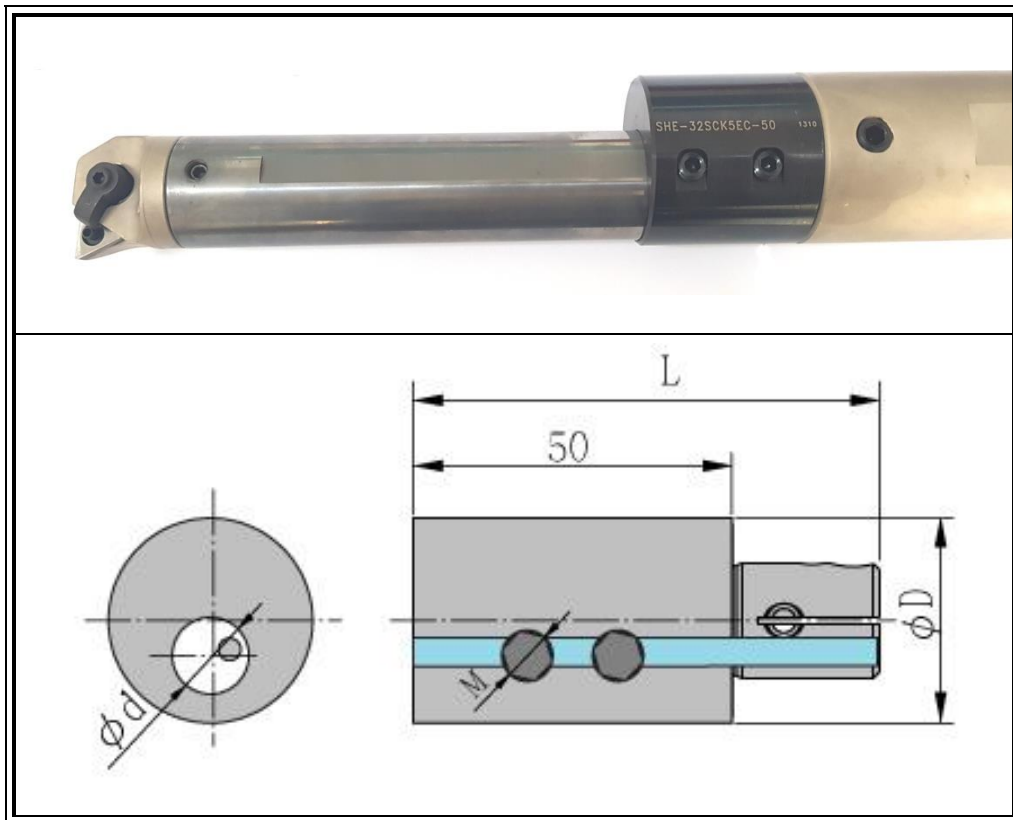

# Zy 模組式偏心套筒 Modular Eccentric Sleeve

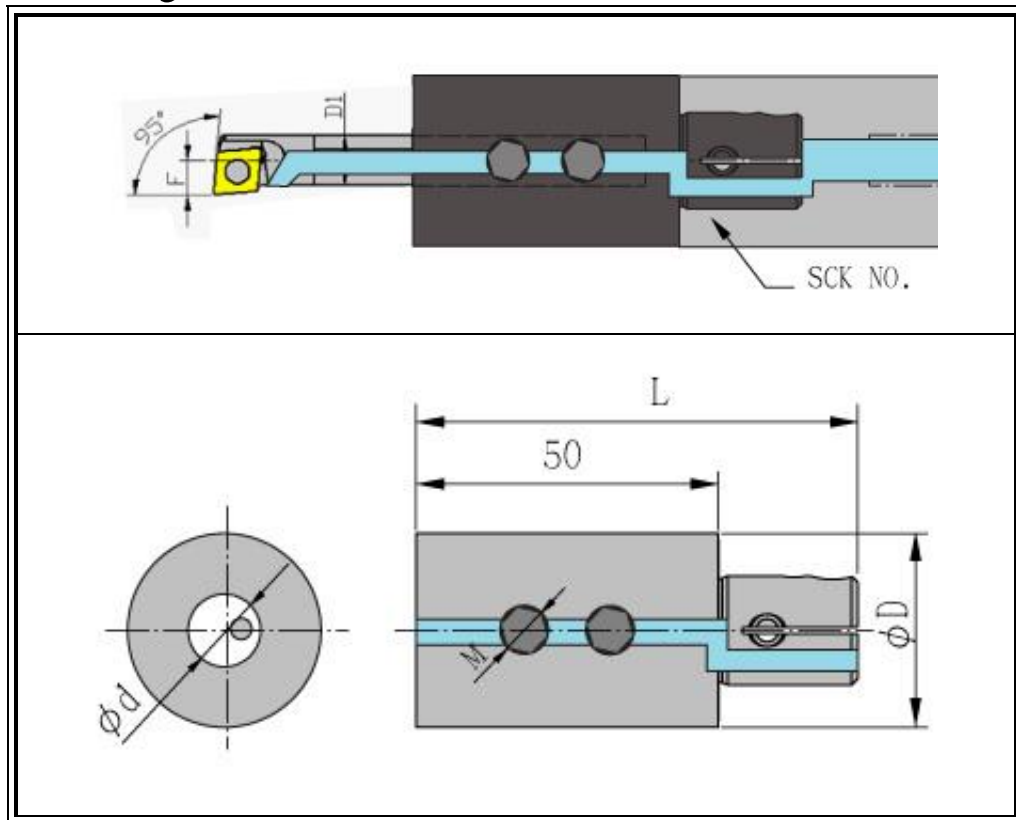

Stock	型號 Model No.	D	d	L	 螺絲 Screw	 板手 Wrench
●	SHE-12SCK3EC-50	32	12	73	SETM8x6L	L4.0
●	SHE-16SCK3EC-50	32	16			
●	SHE-20SCK3EC-50	32	20			
●	SHE-12SCK4EC-50	40	12	74	SETM8x10L	
●	SHE-16SCK4EC-50	40	16			
●	SHE-20SCK4EC-50	40	20			
●	SHE-25SCK4EC-50	40	25		SETM8x6L	
●	SHE-12SCK5EC-50	50	12	80.5	SETM8x10L	
●	SHE-16SCK5EC-50	50	16			
●	SHE-20SCK5EC-50	50	20			
●	SHE-25SCK5EC-50	50	25			
●	SHE-32SCK5EC-50	50	21		SETM8x8L	

# Zy 模組式套筒 Modular Sleeve



Stock	型號 Model No.	D	d	L	 螺絲 Screw	 板手 Wrench
●	SHE-12SCK3-50	32	12	73	SETM8x6L	4.0
●	SHE-16SCK3-50	32	16			
●	SHE-20SCK3-50	32	20			
●	SHE-12SCK4-50	40	12	74	SETM8x10L	
●	SHE-16SCK4-50	40	16			
●	SHE-20SCK4-50	40	20			
●	SHE-25SCK4-50	40	25		SETM8x6L	
●	SHE-12SCK5-50	50	12	80.5	SETM8x10L	
●	SHE-16SCK5-50	50	16			
●	SHE-20SCK5-50	50	20			
●	SHE-25SCK5-50	50	25			
●	SHE-32SCK5-50	50	21			SETM8x8L



External Turning Tool

# With Coolant 外徑出水車刀



負角型



負角型



牙刀



正角型



走心式







## 全刻件-雙面拘束大壓板

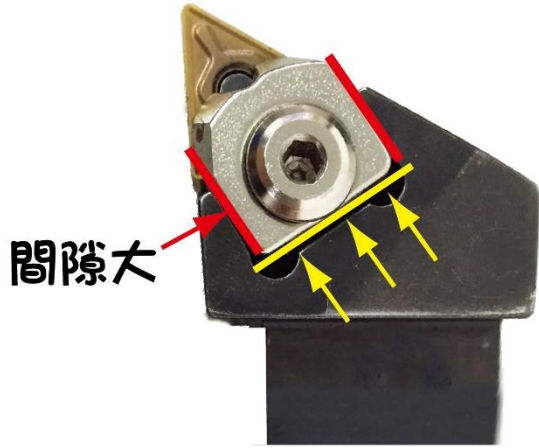

間隙大

直線貼合定位效果差

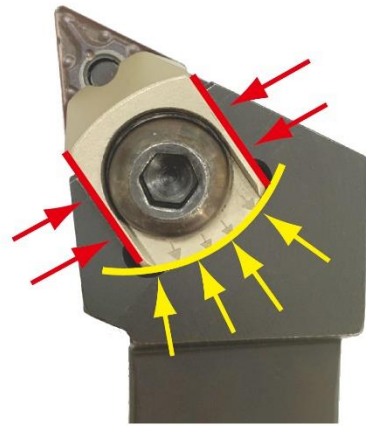

大圓弧的設計

使壓板重複定位更準確

## W Type 出水車刀

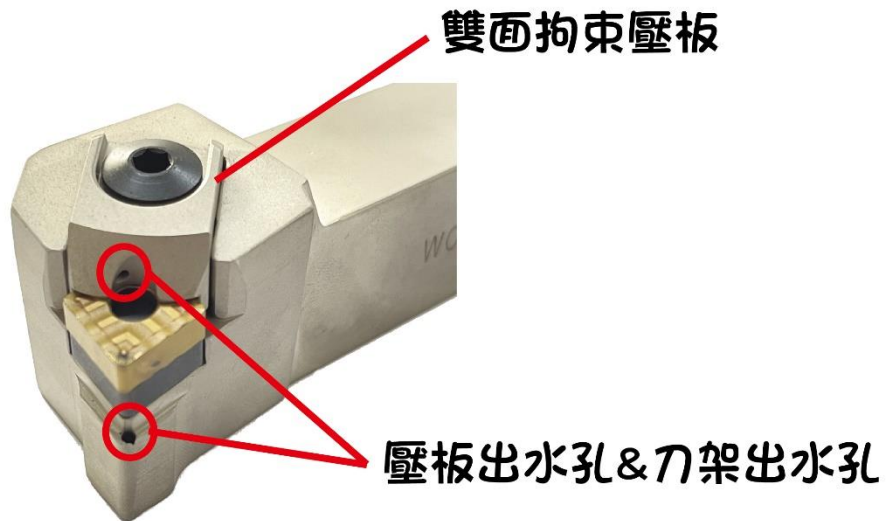

雙面拘束壓板

壓板出水孔&刀架出水孔

## 噴頭式出水車刀

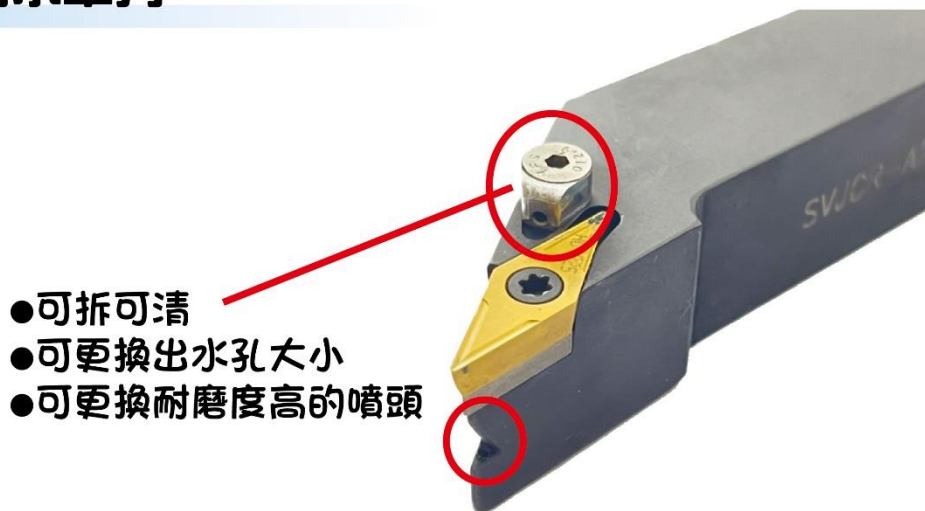

- 可拆可清
- 可更換出水孔大小
- 可更換耐磨度高的噴頭



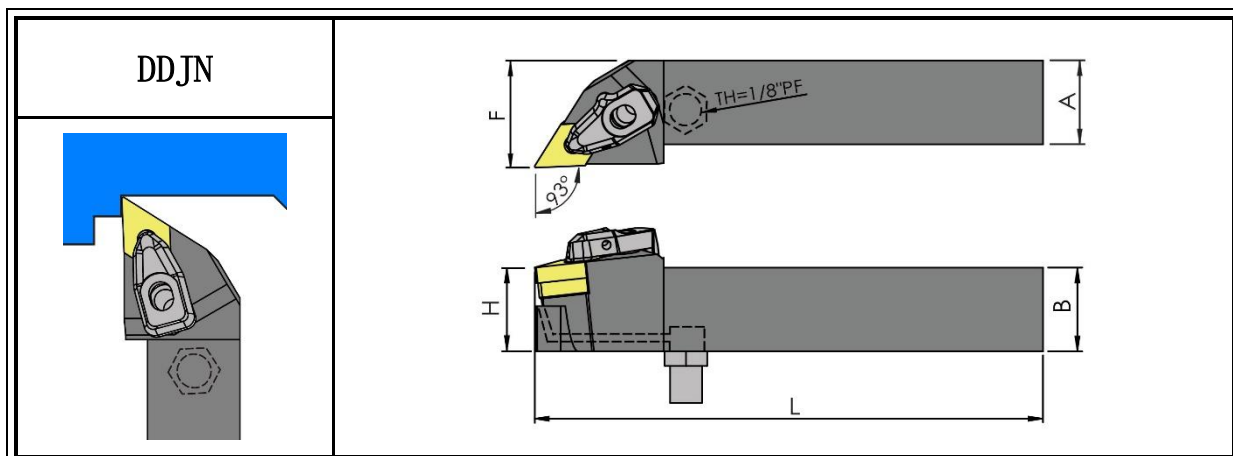



# Zy 外徑出水車刀 Tool Holder With Coolant

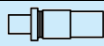

Stock	型號 Model No.	A	B	H	F	L	刀片 Insert
●	DDJNR/L-A2020K-16	20	20	20	25	125	DN1604
●	DDJNR/L-A2525M-16	25	25	25	32	150	

●:庫存 ○:非標準庫存(請確認交貨期)

## 配件 Tool Parts :

 墊片 Shim	 中心柱 Shim Screw	 壓板 Clamp	 螺絲 Clamp Screw	 彈簧 Spring	 O型環 O-ring	 板手 Wrench
DMS442	DDSM4	DDPSE-2916	DS625	SP85	3X1	L2.5 L3.0



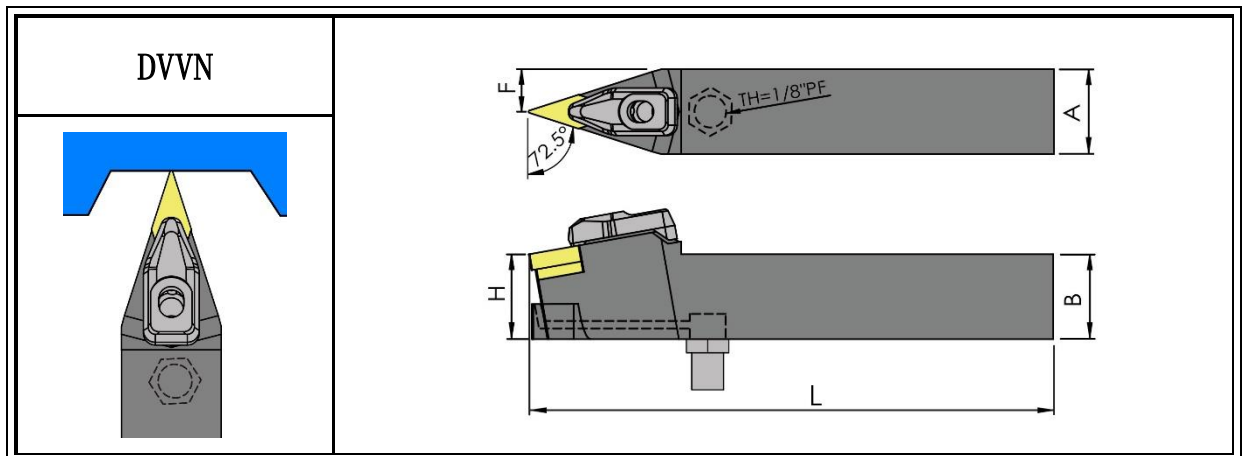



# Zy 外徑出水車刀 Tool Holder With Coolant

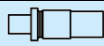

Stock	型號 Model No.	A	B	H	F	L	刀片 Insert
●	DVVNN-A2020K-16	20	20	20	10	125	VN1604
●	DVVNN-A2525M-16	25	25	25	12.5	150	

●:庫存 In Stock    ○:非標準庫存(請確認交貨期) Non-standard Stock

## 配件 Tool Parts :

 墊片 Shim	 中心柱 Shim Screw	 壓板 Clamp	 螺絲 Clamp Screw	 彈簧 Spring	 O型環 O-ring	 板手 Wrench
GMV322	DVSM4	DVPSE-3214	DS625	SP85	3X1	L2.5 L3.0



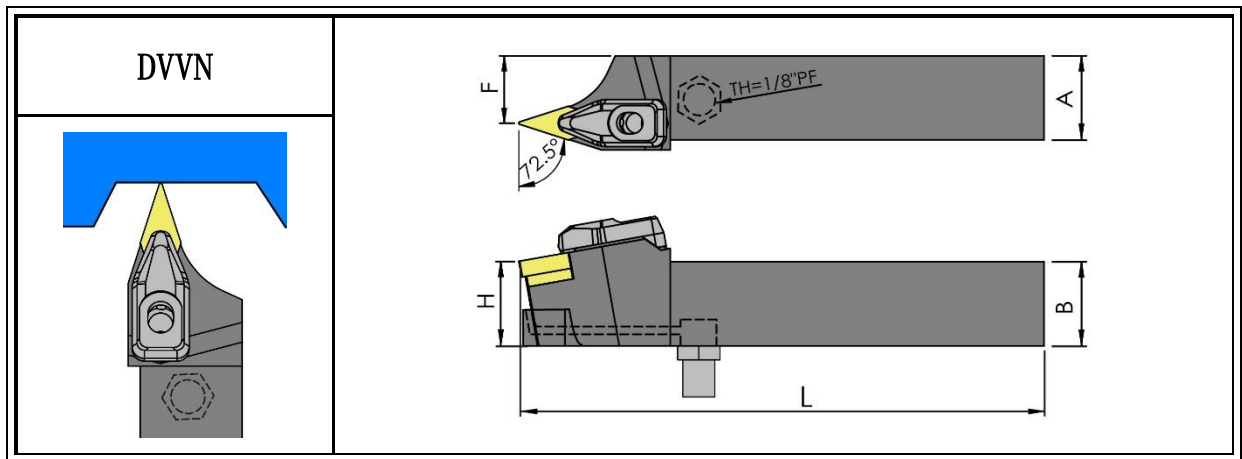



# Zy 外徑出水車刀 Tool Holder With Coolant

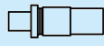

Stock	型號 Model No.	A	B	H	F	L	刀片 Insert
●	DVVNR/L-A2020K-16	20	20	20	15	125	VN1604
●	DVVNR/L-A2525M-16	25	25	25	20	150	

●:庫存 In Stock    ○:非標準庫存(請確認交貨期) Non-standard Stock

## 配件 Tool Parts :

 墊片 Shim	 中心柱 Shim Screw	 壓板 Clamp	 螺絲 Clamp Screw	 彈簧 Spring	 O型環 O-ring	 板手 Wrench
GMV322	DVSM4	DVPSE-3214	DS625	SP85	3X1	L2.5 L3.0



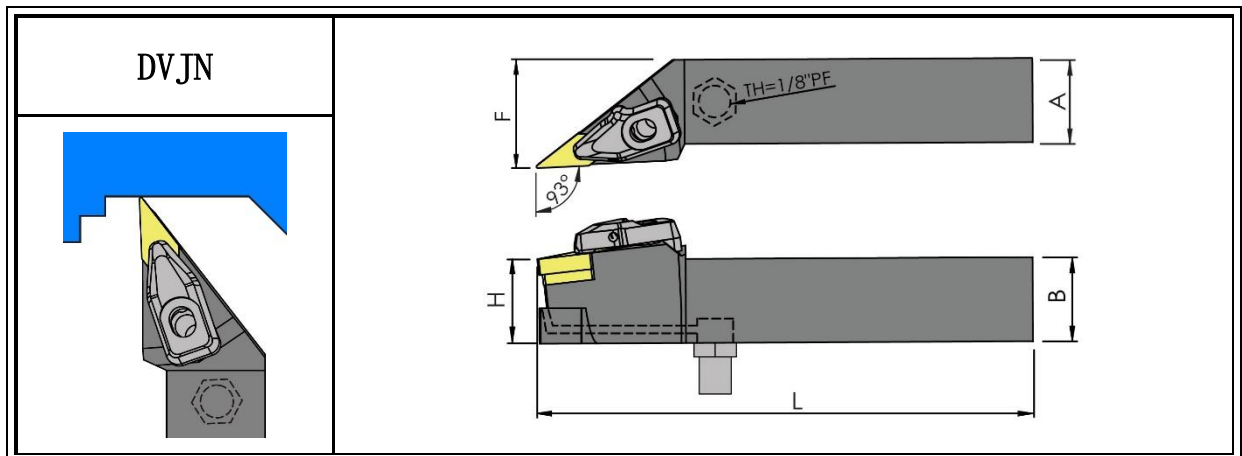



# Zy 外徑出水車刀 Tool Holder With Coolant

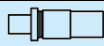

Stock	型號 Model No.	A	B=H	H	F	L	刀片 Insert
●	DVJNR/L-A2020K-16	20	20	20	25	125	VN1604
●	DVJNR/L-A2525M-16	25	25	25	32	150	

●:庫存 In Stock    ○:非標準庫存(請確認交貨期) Non-standard Stock

## 配件 Tool Parts :

 墊片 Shim	 中心柱 Shim Screw	 壓板 Clamp	 螺絲 Clamp Screw	 彈簧 Spring	 O型環 O-ring	 板手 Wrench
GMV322	DVSM4	DVPSE-3214	DS625	SP85	3X1	L2.5 L3.0

# Zy 外徑出水車刀 Tool Holder With Coolant

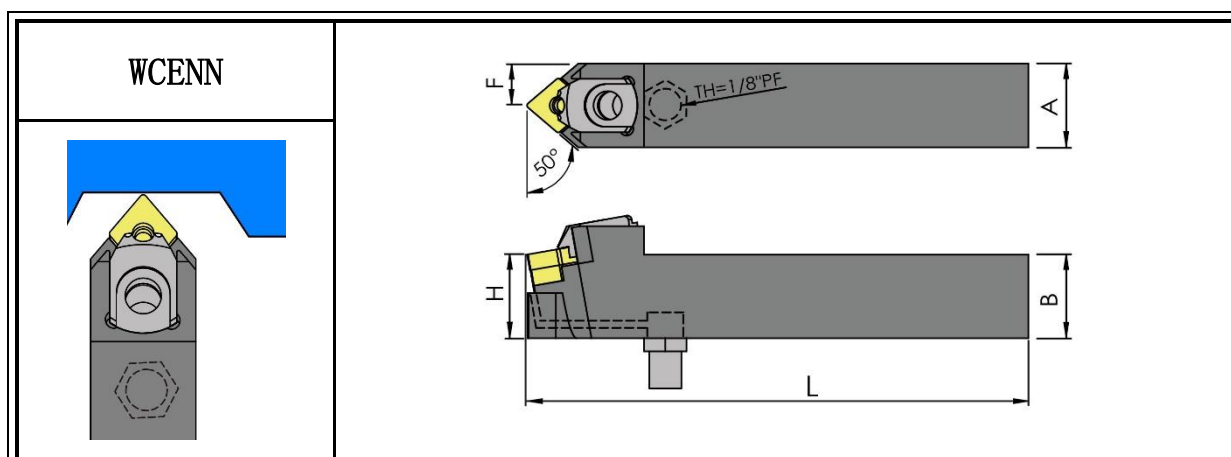

Stock	型號 Model No.	A	B=H	F	L	墊片 Shim	中心柱 Shim Screw	W 型壓板組 W Type Clamp	板手 Wrench	刀片 Insert
●	WCENN-A2020K-12	20	20	10	125	CMS422	LCS-618A	WCPSE-2516A	L3.0	CN1204
●	WCENN-A2525M-12	25	25	12.5	150				L4.0	

●:庫存 In Stock    ○:非標準庫存(請確認交貨期) Non-standard Stock

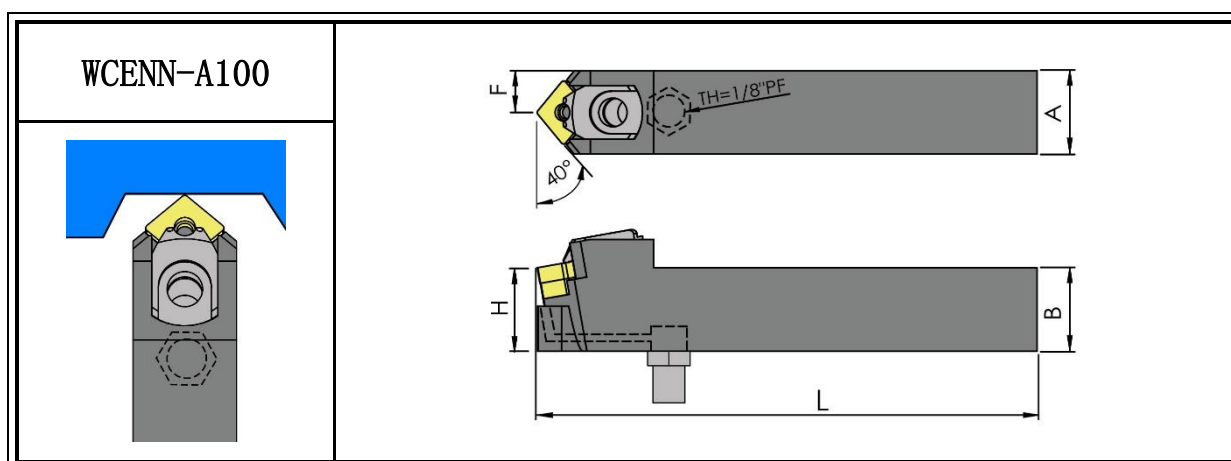

Stock	型號 Model No.	A	B=H	F	L	墊片 Shim	中心柱 Shim Screw	W 型壓板組 W Type Clamp	板手 Wrench	刀片 Insert
●	WCENN-A2020K-12-A100	20	20	10	125	CMS422	LCS-618A	WCPSE-2516A	L3.0	CN1204
●	WCENN-A2020K-12-A100	25	25	12.5	150				L4.0	

●:庫存 In Stock    ○:非標準庫存(請確認交貨期) Non-standard Stock

# Zy 外徑出水車刀 Tool Holder With Coolant

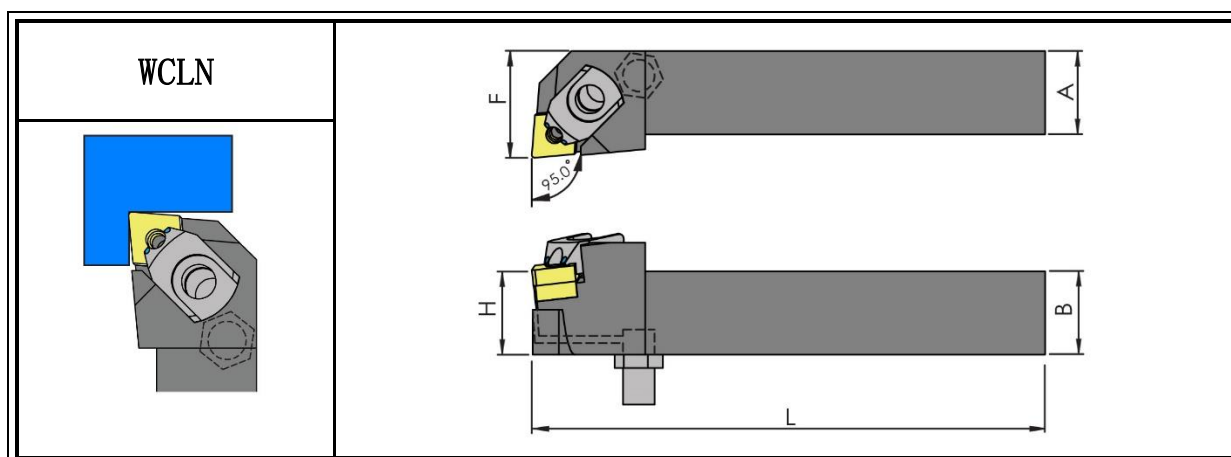

Stock	型號 Model No.	A	B=H	F	L	 墊片 Shim	 中心柱 Shim Screw	 W 型壓板組 W Type Clamp	 板手 Wrench	刀片 Insert
●	WCLNR/L-A2020K-12	20	20	25	125	CMS422	LCS-618A	WCPSE-2516A	L3.0	CN1204
●	WCLNR/L-A2525M-12	25	25	32	150				L4.0	

●:庫存 In Stock    ○:非標準庫存(請確認交貨期) Non-standard Stock

# Zy 外徑出水車刀 Tool Holder With Coolant

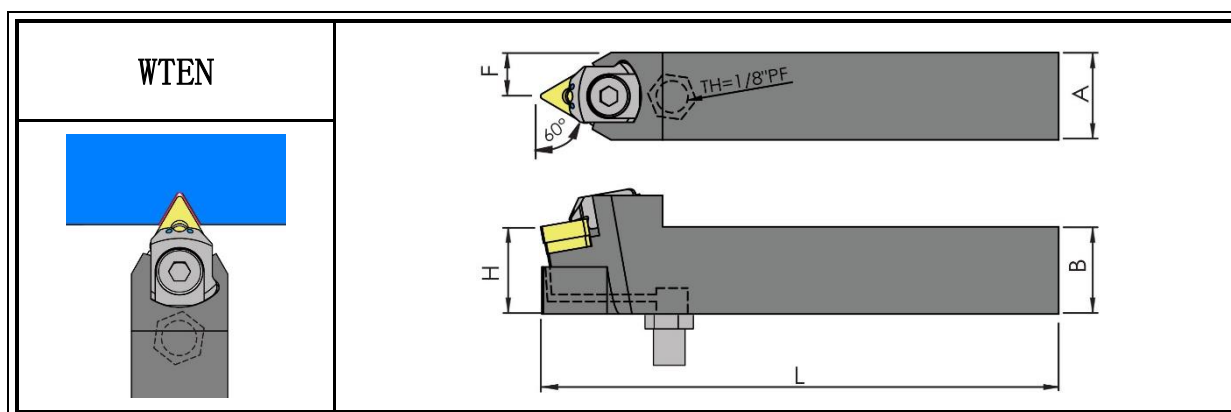

Stock	型號 Model No.	A	B=H	F	L	 墊片 Shim	 中心柱 Shim Screw	 W 型壓板組 W Type Clamp	 板手 Wrench	刀片 Insert
●	WTENN-A2020K-16	20	20	10	125	TMS322	LCS-519-1A	WTPSE-2115A	L2.5 L4.0	TN1604
●	WTENN-A2525M-16	25	25	12.5	150					

●:庫存 In Stock    ○:非標準庫存(請確認交貨期) Non-standard Stock

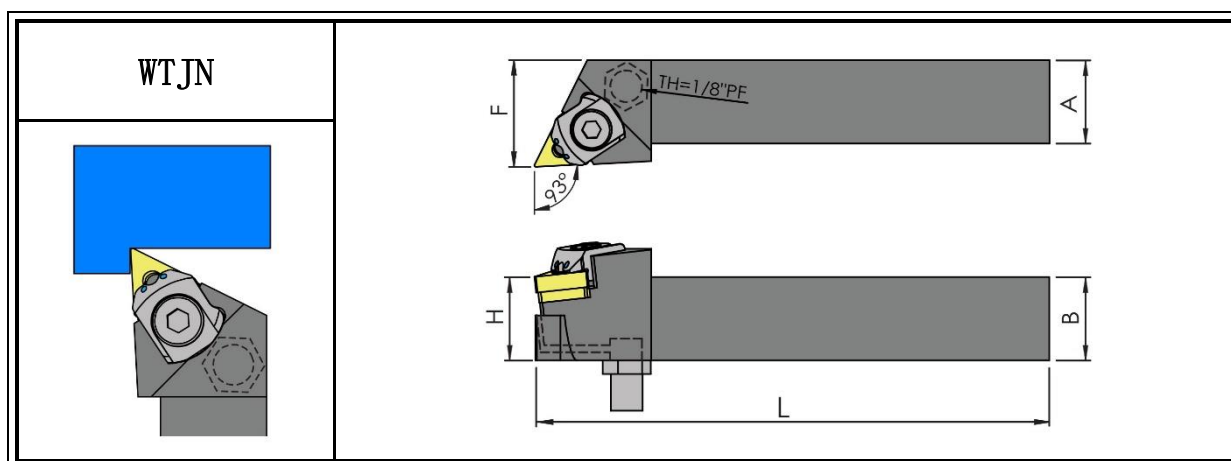

Stock	型號 Model No.	A	B=H	F	L	 墊片 Shim	 中心柱 Shim Screw	 W 型壓板組 W Type Clamp	 板手 Wrench	刀片 Insert
●	WTJNR/L-A2020K-16	20	20	25	125	TMS322	LCS-519-1A	WTPSE-2115A	L2.5 L4.0	TN1604
●	WTJNR/L-A2525M-16	25	25	32	150					

●:庫存 In Stock    ○:非標準庫存(請確認交貨期) Non-standard Stock



# Zy 外徑出水車刀 Tool Holder With Coolant

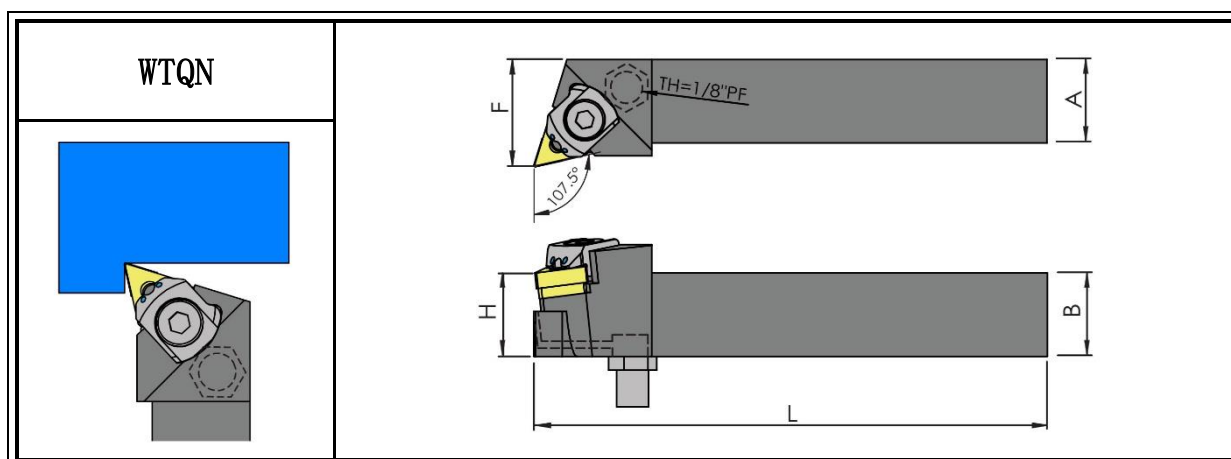

Stock	型號 Model No.	A	B=H	F	L	 墊片 Shim	 中心柱 Shim Screw	 W 型壓板組 W Type Clamp	 板手 Wrench	刀片 Insert
●	WTQNR/L-A2020K-16	20	20	25	125	TMS322	LCS-519-1A	WTPSE-2115A	L2.5 L4.0	TN1604
●	WTQNR/L-A2525M-16	25	25	32	150					

●:庫存 In Stock    ○:非標準庫存(請確認交貨期) Non-standard Stock

# Zy 外徑出水車刀 Tool Holder With Coolant

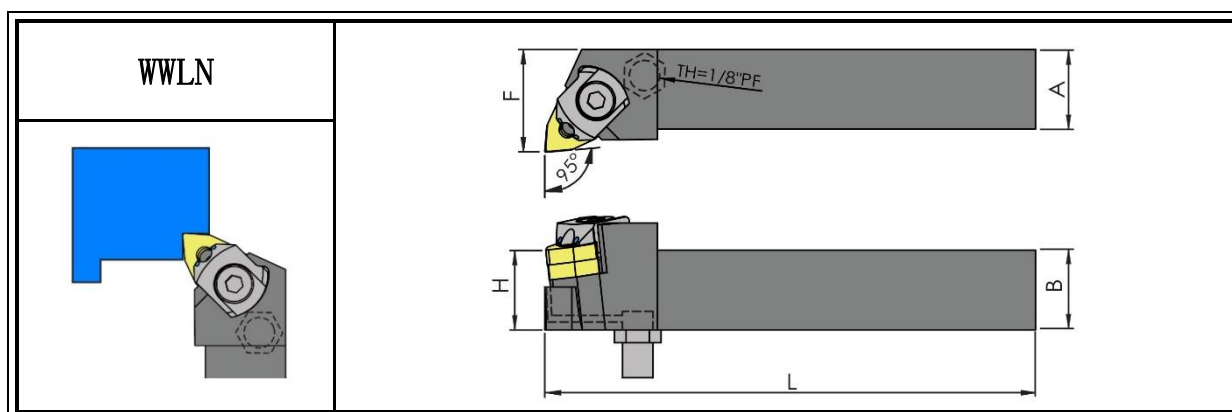

Stock	型號 Model No.	A	B=H	F	L	 墊片 Shim	 中心柱 Shim Screw	 W 型壓板組 W Type Clamp	 板手 Wrench	刀片 Insert
●	WWLNR/L-A2020K-08	20	20	25	125	WMS432	LCS-618A	WWPSE-2316A	L3.0	WN0804
●	WWLNR/L-A2525M-08	25	25	32	150				L4.0	

●:庫存 In Stock    ○:非標準庫存(請確認交貨期) Non-standard Stock

# Zy 外徑出水車刀 Tool Holder With Coolant

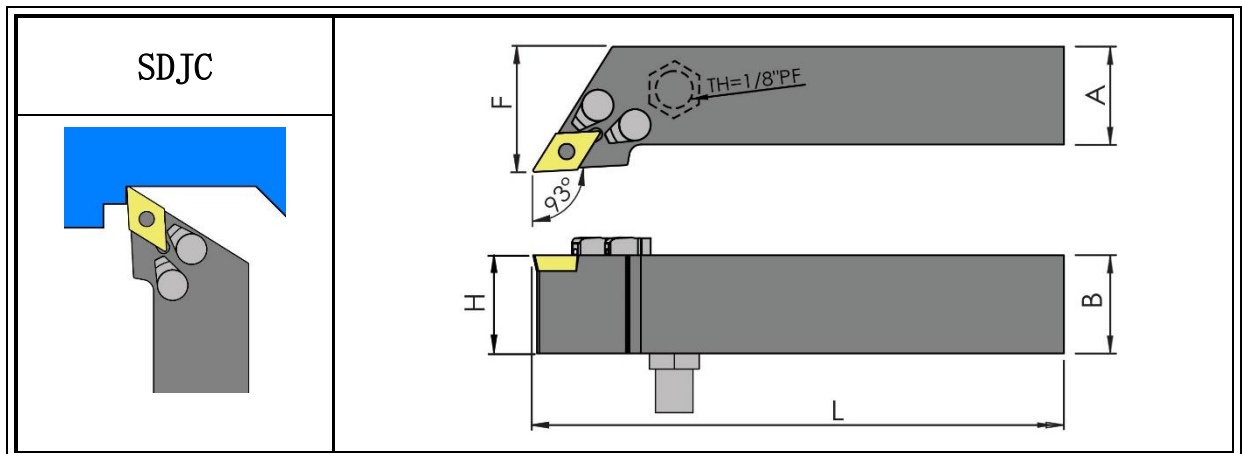

Stock	型號 Model No.	F	A	B=H	L	螺絲 Screw	板手 Wrench	刀片 Insert
●	SDJCR/L-A2020K-11	25	20	20	125	M4x8. 8x5. 4	T15	DC11T3
●	SDJCR/L-A2525M-11	32	25	25	150			

●:庫存 In Stock    ○:非標準庫存(請確認交貨期) Non-standard Stock

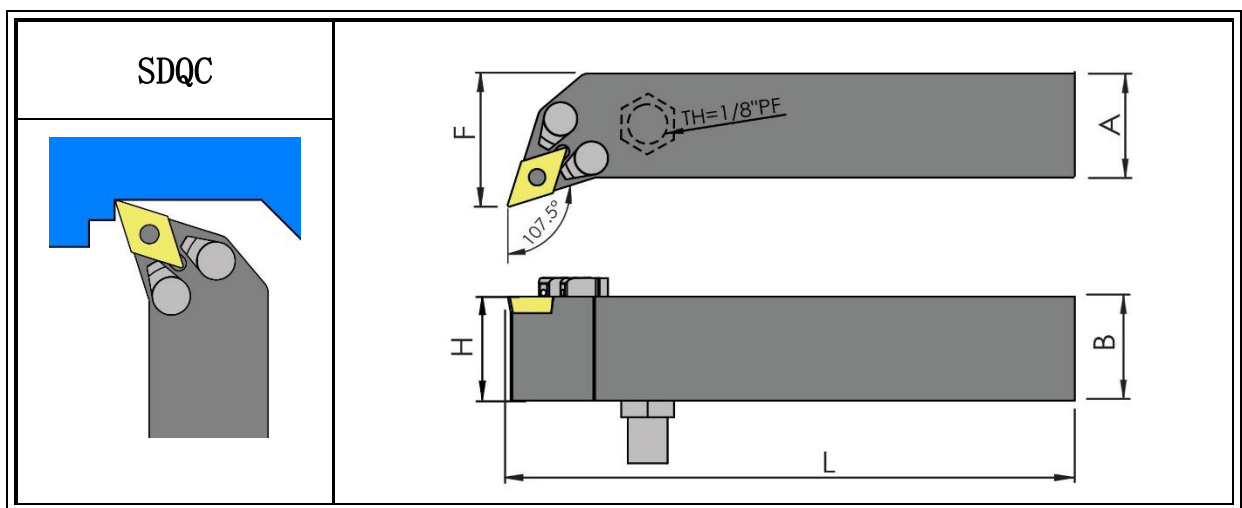

Stock	型號 Model No.	F	A	B=H	L	螺絲 Screw	板手 Wrench	刀片 Insert
○	SDQCR/L-A2020K-11	25	20	20	125	M4x8. 8x5. 4	T15	DC11T3
●	SDQCR/L-A2525M-11	32	25	25	150			

●:庫存 In Stock    ○:非標準庫存(請確認交貨期) Non-standard Stock

# Zy 外徑出水車刀 Tool Holder With Coolant

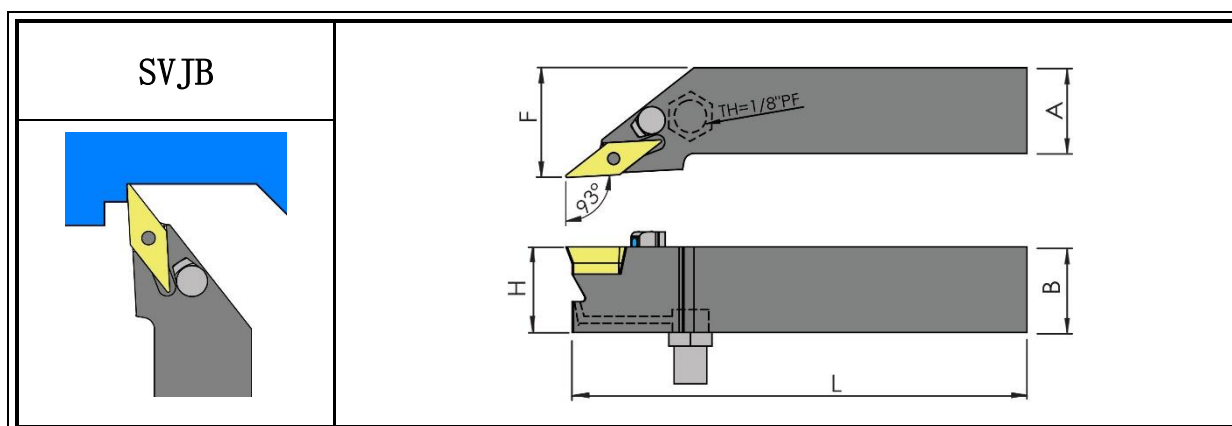

Stock	型號 Model No.	F	A	B=H	L	墊片 Shim	墊片螺絲 Shim Screw	螺絲 Screw	板手 Wrench	刀片 Insert
●	SVJBR/L-A2020K-16	25	20	20	125	VSS322	MDS5035A	M3. 5x11. 4x5. 7	T15 L:3.5	VB1604
●	SVJBR/L-A2525M-16	32	25	25	150					

●:庫存 In Stock    ○:非標準庫存(請確認交貨期) Non-standard Stock

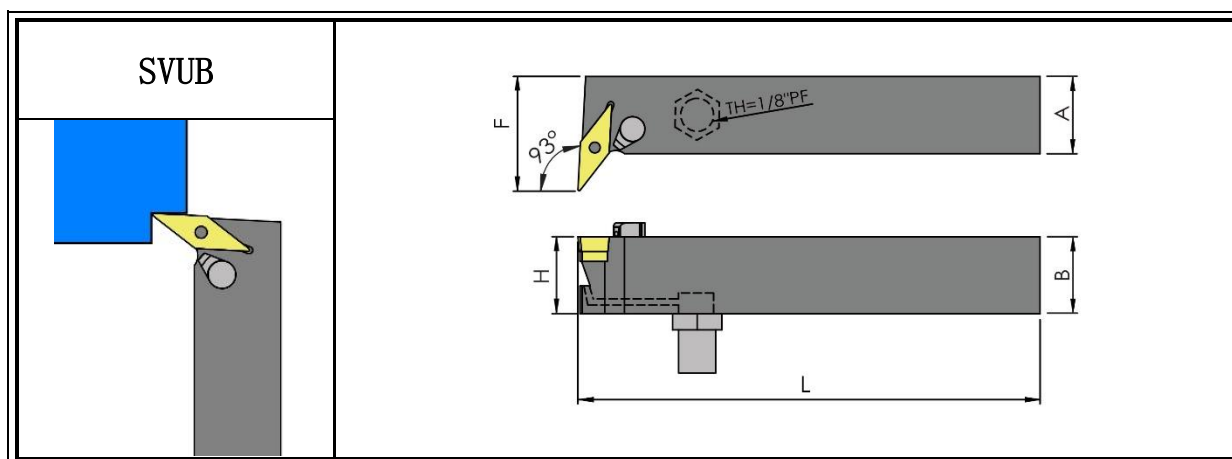

Stock	型號 Model No.	F	A	B=H	L	墊片 Shim	墊片螺絲 Shim Screw	螺絲 Screw	板手 Wrench	刀片 Insert
●	SVUBR/L-A2020K-16	32	20	20	125	VSS322	MDS5035A	M3. 5x11. 4x5. 7	T15 L:3.5	VB1604
●	SVUBR/L-A2525M-16	37	25	25	150					

●:庫存 In Stock    ○:非標準庫存(請確認交貨期) Non-standard Stock

# Zy 外徑出水車刀 Tool Holder With Coolant

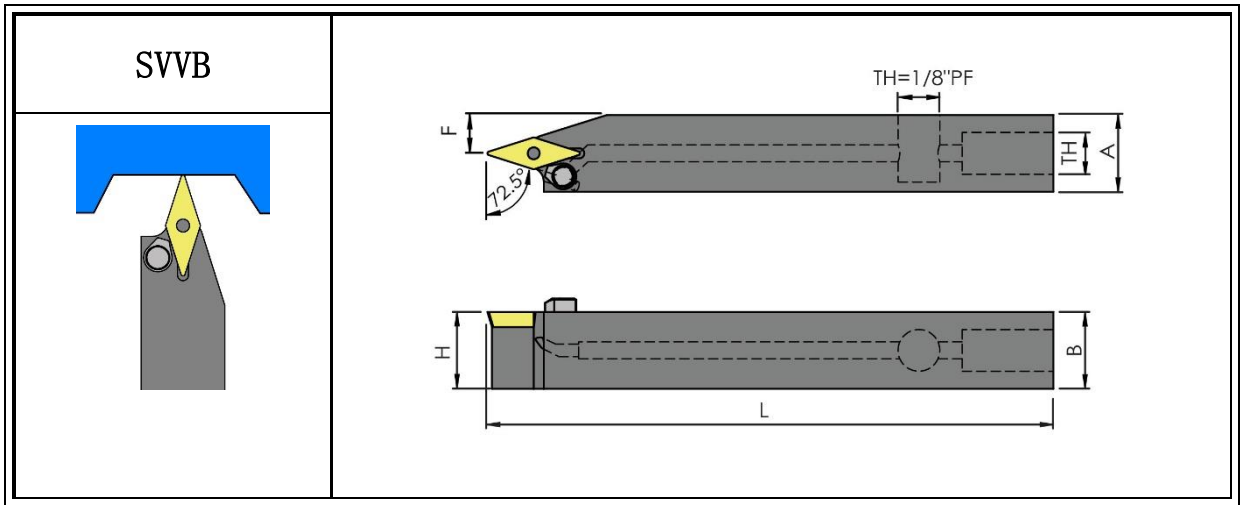

Stock	型號 Model No.	F	A	B=H	L	螺絲 Screw	板手 Wrench	刀片 Insert
●	SVVBN-A1212H-11	6	12	12	100	M2.5x6.0x3.6	T8	VB1103
●	SVVBN-A1616H-11	8	16	16	100			

●:庫存 In Stock    ○:非標準庫存(請確認交貨期) Non-standard Stock

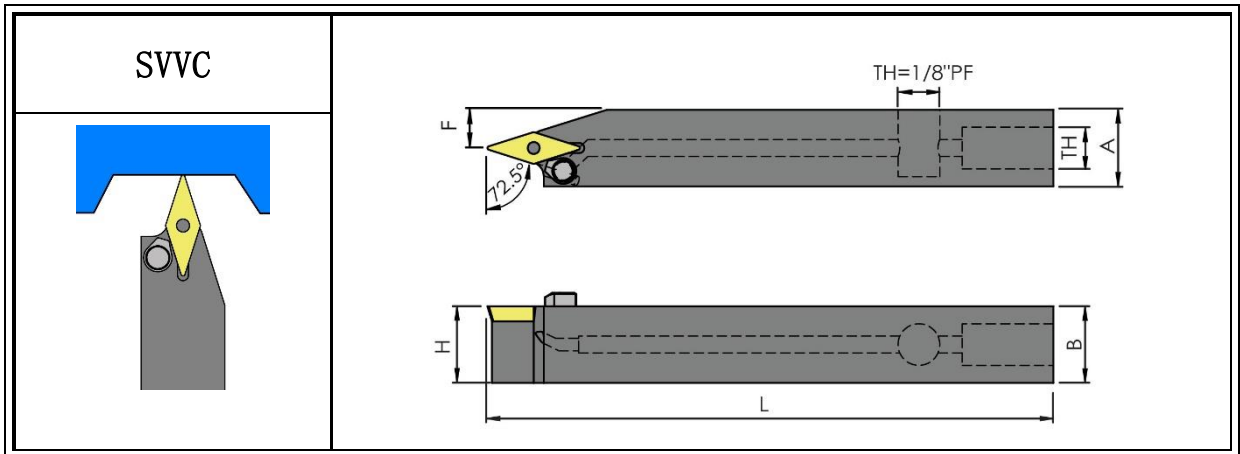

Stock	型號 Model No.	F	A	B=H	L	螺絲 Screw	板手 Wrench	刀片 Insert
●	SVVCN-A1212H-11	6	12	12	100	M2.5x6.0x3.6	T8	VC1103
●	SVVCN-A1616H-11	8	16	16	100			

●:庫存 In Stock    ○:非標準庫存(請確認交貨期) Non-standard Stock

# Zy 外徑出水車刀 Tool Holder With Coolant

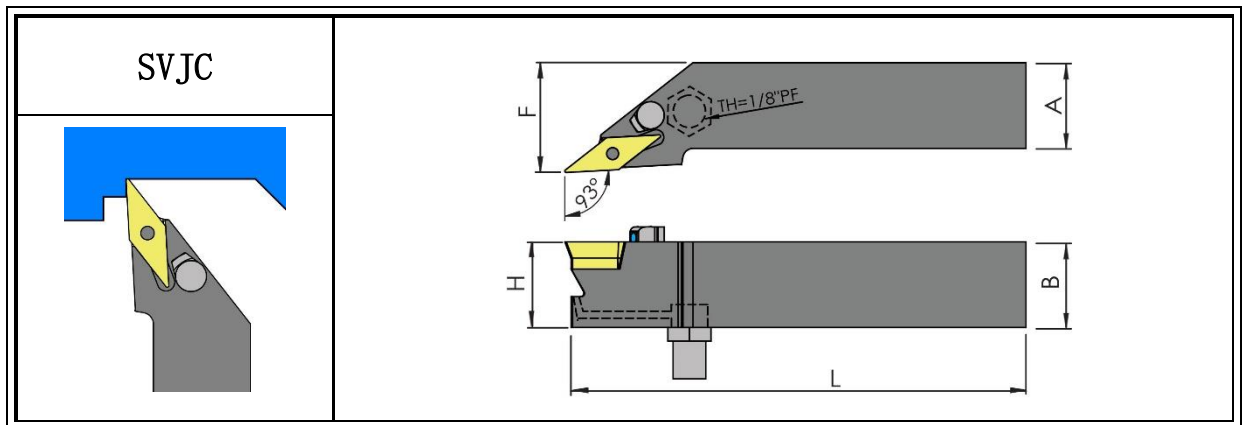

Stock	型號 Model No.	F	A	B=H	L	墊片 Shim	墊片螺絲 Shim Screw	螺絲 Screw	板手 Wrench	刀片 Insert
●	SVJCR/L-A2020K-16A	25	20	20	125	VSS322	MDS5035A	M3. 5x11. 4x5. 7	T15 L:3. 5	VC1604
●	SVJCR/L-A2525M-16A	32	25	25	150					

●:庫存 In Stock    ○:非標準庫存(請確認交貨期) Non-standard Stock

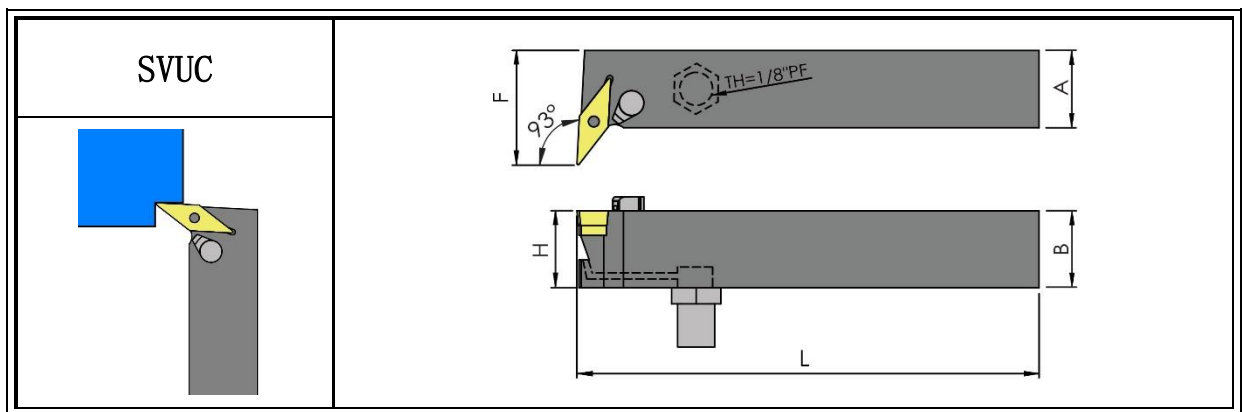

Stock	型號 Model No.	F	A	B=H	L	墊片 Shim	墊片螺絲 Shim Screw	螺絲 Screw	板手 Wrench	刀片 Insert
●	SVUCR/L-A2020K-16	32	20	20	125	VSS322	MDS5035A	M3. 5x11. 4x5. 7	T15 L:3. 5	VC1604
●	SVUCR/L-A2525M-16	37	25	25	150					

●:庫存 In Stock    ○:非標準庫存(請確認交貨期) Non-standard Stock



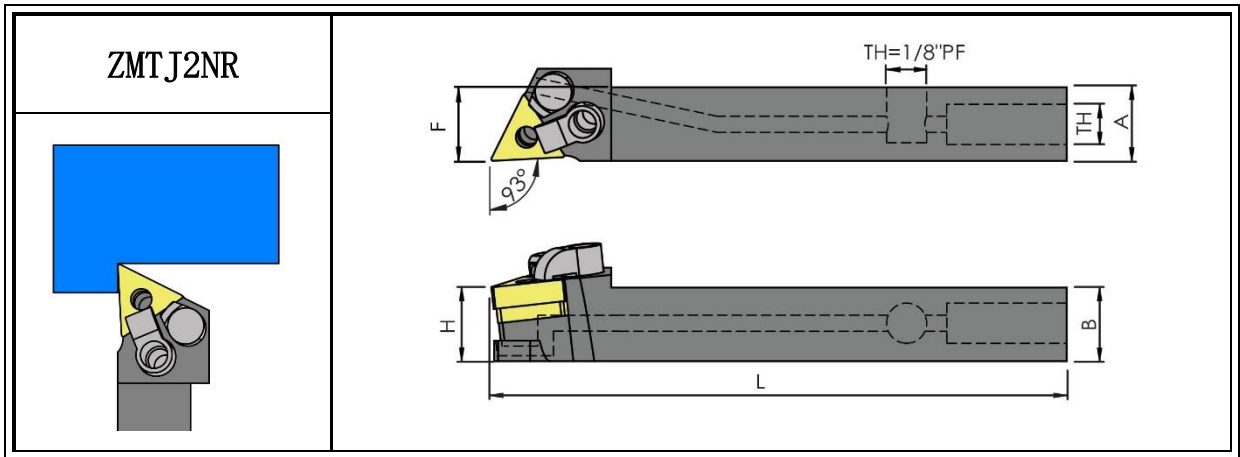

# Zy 外徑出水車刀-走心式 Tool Holder With Coolant For Automatic Lathes



Stock	型號 Model No.	F	A	B=H	L	刀片 Insert
●	ZMTJ2NR/L-A1616K-16	16	16	16	125	VN1604

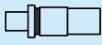

●:庫存 In Stock    ○:非標準庫存(請確認交貨期) Non-standard Stock

## 配件 Tool Parts :

				
墊片 Shim	中心柱 Shim Screw	壓板 Clamp	雙頭螺絲 Clamp Screw	板手 Wrench
TMS322	LCS-513A	DVPSE-3214	DS625	L2.0 L2.5

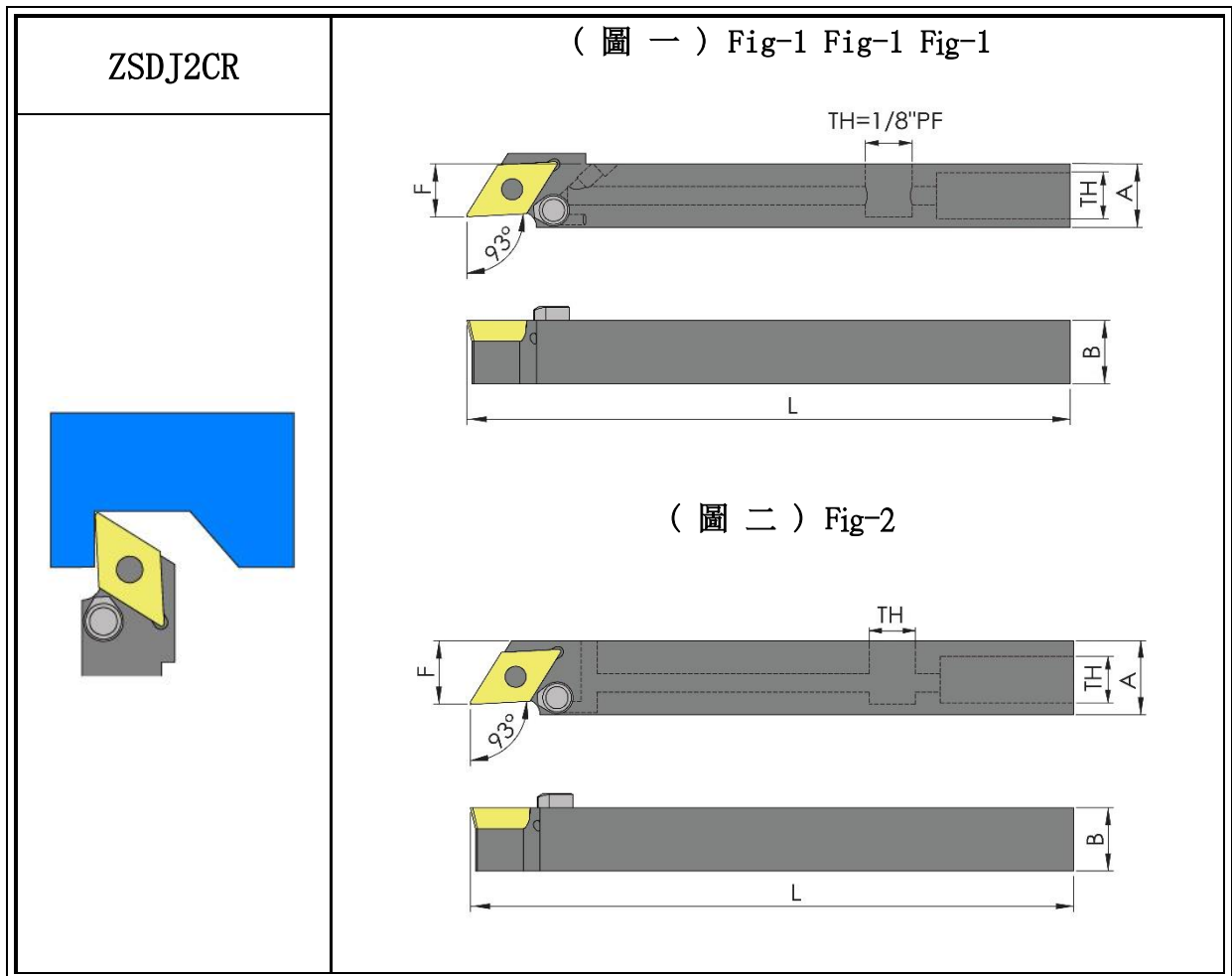
# Zy 外徑出水車刀-走心式 Tool Holder With Coolant For Automatic Lathes



Stock	型號 Model No.	圖 Fig	F	A	B	L	 螺絲 Screw	 板手 Wrench	刀片 Insert
●	ZSDJ2CR/L-A1212K-11	1	10	12	12	125	M4x8.8x5.4	T15	DC11T3
●	ZSDJ2CR/L-A1616K-11	2	14	16	16	125			

●:庫存 In Stock    ○:非標準庫存(請確認交貨期) Non-standard Stock



# Zy 外徑出水車刀-走心式 Tool Holder With Coolant For Automatic Lathes

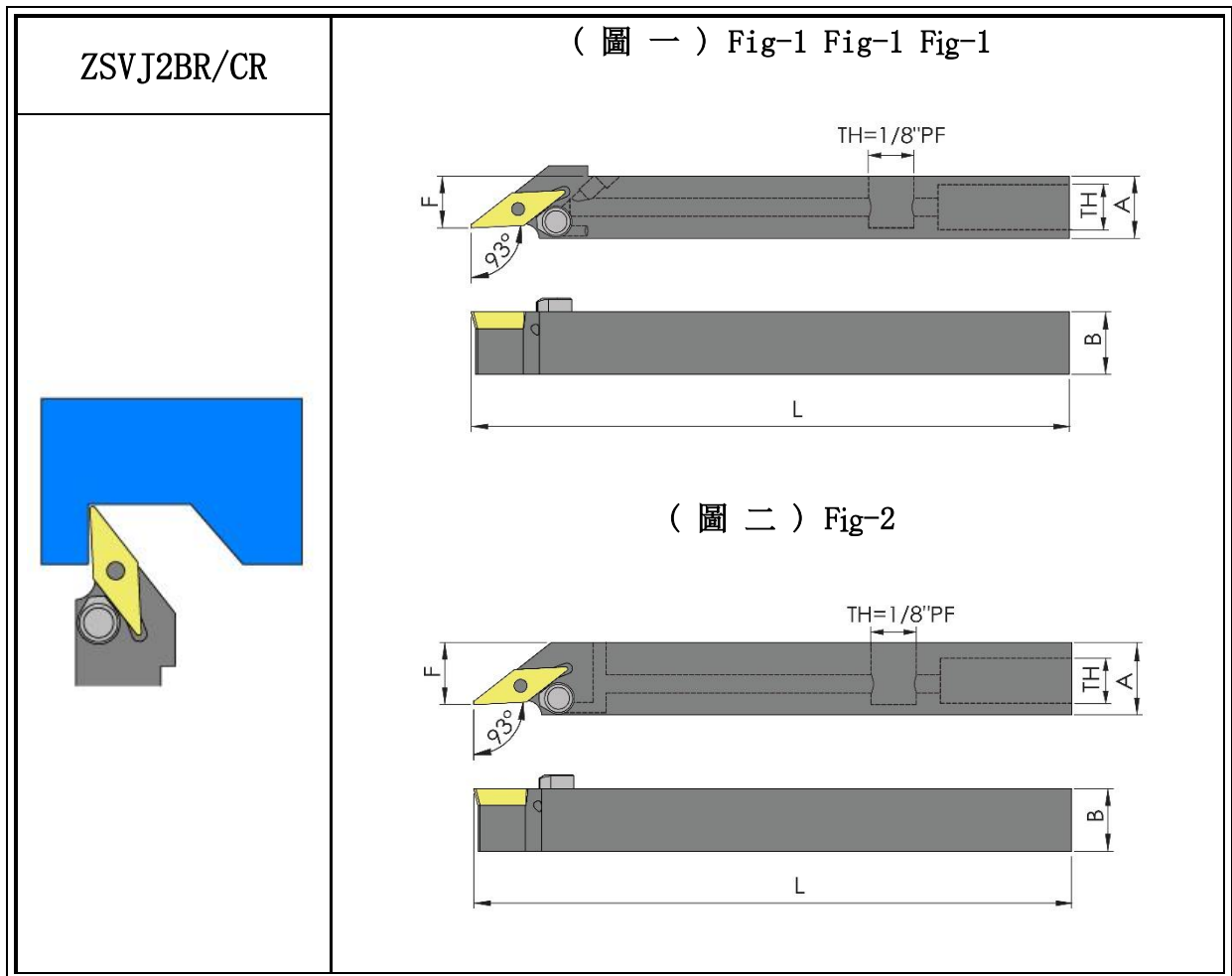



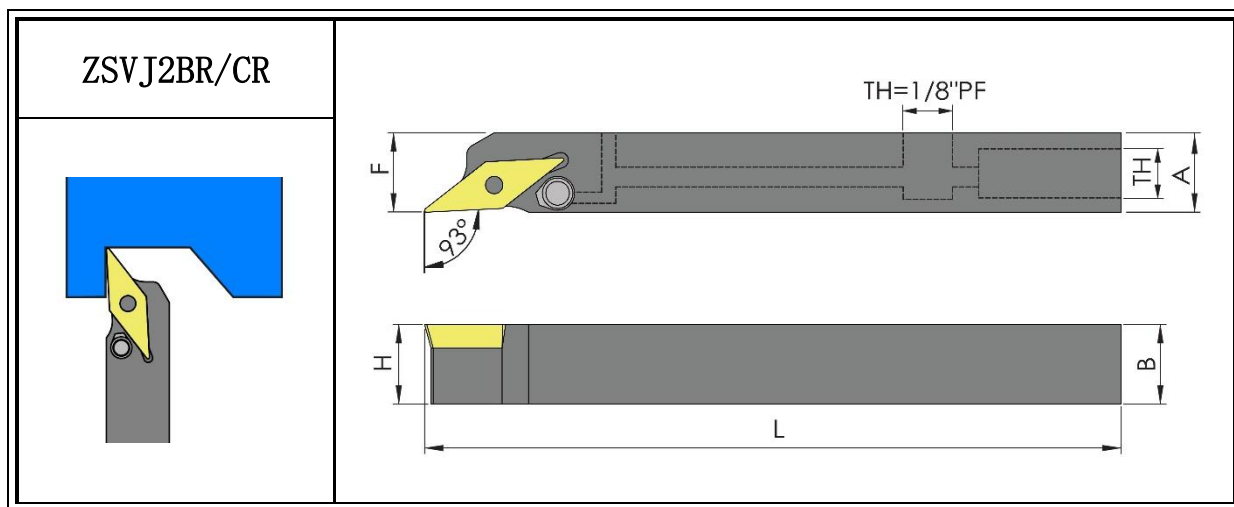

Stock	型號 Model No.	圖 Fig	F	A	B	L	螺絲 Screw	扳手 Wrench	刀片 Insert
●	ZSVJ2BR-A1212K-11	1	10	12	12	125	M2.5x6.0x3.6	T8	VB1103
●	ZSVJ2BR-A1616K-11	2	14	16	16	125			
●	ZSVJ2CR-A1212K-11	1	10	12	12	125	M2.5x6.0x3.6	T8	VC1103
●	ZSVJ2CR-A1616K-11	2	14	16	16	125			

●:庫存 In Stock    ○:非標準庫存(請確認交貨期) Non-standard Stock

# Zy 外徑出水車刀-走心式 Tool Holder With Coolant For Automatic Lathes





Stock	型號 Model No.	F	A	B=H	L	 墊片 Shim	 墊片螺絲 Shim Screw	 螺絲 Screw	 板手 Wrench	刀片 Insert
●	ZSVJ2BR/L-A1616K-16AL	16	16	16	125	VSS322	M5	M3.5x11.4x5.7	T15	VB1604
●	ZSVJ2CR/L-A1616K-16AL	16	16	16	125					VC1604

●:庫存 In Stock    ○:非標準庫存(請確認交貨期) Non-standard Stock

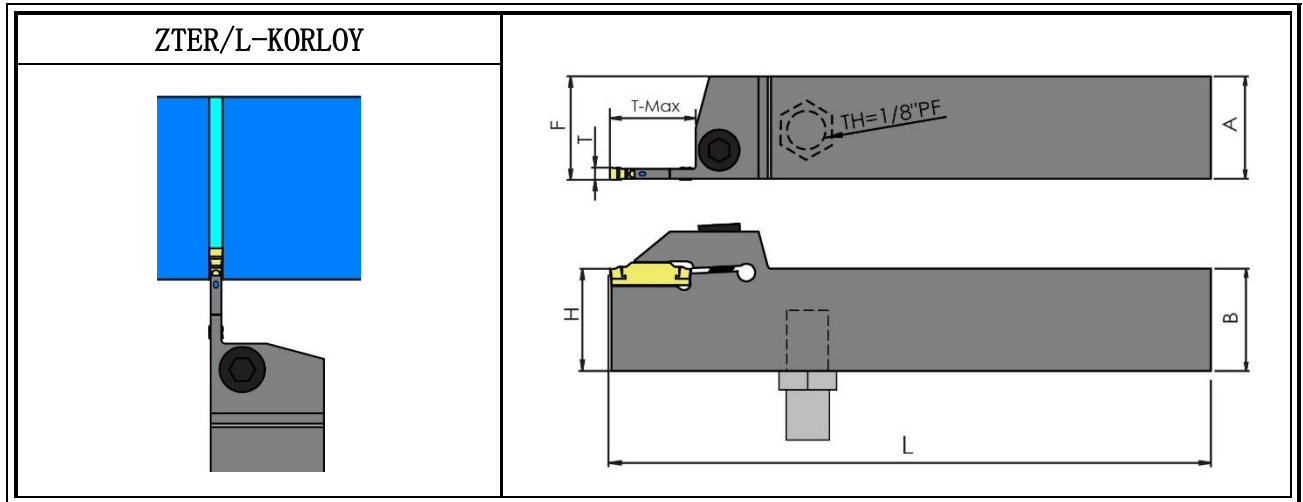
# Zy 外徑出水切槽刀 External Grooving With Coolant



Stock		型號 Model No.	A	B=H	F	L	T	T-Max	 螺絲 Screw	 板手 Wrench
R	L									
●	●	ZTER/L-A2020K-MG2-14	20	20	20	125	2	14	HTM6x20L	L5.0
●	●	ZTER/L-A2020K-MG2-18	20	20	20	125		18	HTM6x20L	
●	●	ZTER/L-A2525M-MG2-14	25	25	25	150	2	14	HTM6x25L	
●	●	ZTER/L-A2525M-MG2-18	25	25	25	150		18	HTM6x25L	
●	●	ZTER/L-A2020K-MG3-20	20	20	20	125	3	20	HTM6x20L	
●	○	ZTER/L-A2525M-MG3-10	25	25	25	150		10	HTM6x25L	
●	●	ZTER/L-A2525M-MG3-20	25	25	25	150		20	HTM6x25L	
●	●	ZTER/L-A2020K-MG4-20	20	20	20	125	4	20	HTM6x20L	L5.0
●	●	ZTER/L-A2525M-MG4-20	25	25	25	150		20	HTM6x25L	
○	○	ZTER/L-A2020K-MG5-25	20	20	20	125	5	25	HTM6x20L	L5.0
●	●	ZTER/L-A2525M-MG5-25	25	25	25	150		25	HTM6x25L	

●:庫存 In Stock    ○:非標準庫存(請確認交貨期) Non-standard Stock

刀片 Insert : KORLOY

MG2= MGN200



MG3= MGN300

MG4= MGN400

MG5= MGN500

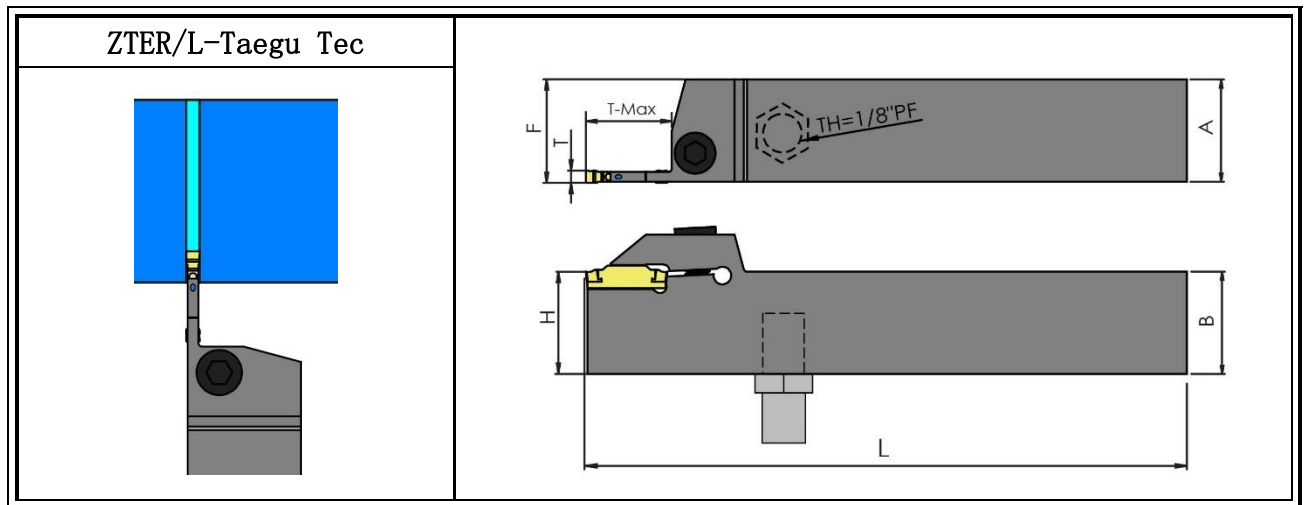
# Zy 外徑出水切槽刀 External Grooving With Coolant





Stock		型號 Model No.	A	B=H	F	L	T	T-Max	 螺絲 Screw	 板手 Wrench
R	L									
●	●	ZTER/L-A2020K-TD2-17	20	20.1	20	125	2	17	HTM6x20L	L5.0
●	○	ZTER/L-A2525M-TD2-17	25	25.1	25	150	2	17	HTM6x25L	
●	○	ZTER/L-A2020K-TD3-20	20	20.3	20	125	3	20	HTM6x20L	
●	○	ZTER/L-A2525M-TD3-20	25	25.3	25	150	3	20	HTM6x25L	
●	○	ZTER/L-A2525M-TD4-25	25	25.5	25	150	4	25	HTM6x16L	
●	○	ZTER/L-A2525M-TD5-32	25	25.5	25	150	5	32	HTM6x25L	

●:庫存 In Stock    ○:非標準庫存(請確認交貨期) Non-standard Stock

刀片 Insert : Taegu Tec

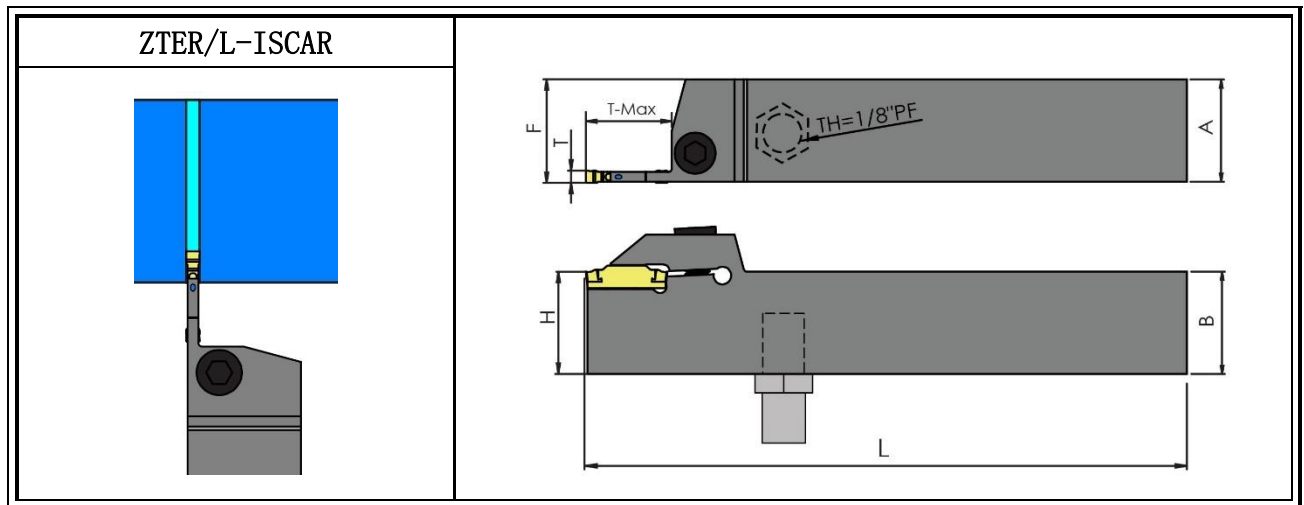
# Zy 外徑出水切槽刀 External Grooving With Coolant



Stock		型號 Model No.	A	B=H	F	L	T	T-Max	 螺絲 Screw	 板手 Wrench
R	L									
●	●	ZTER/L-A2020K-DGN2-17	20	20	20	125	2	17	HTM6x20L	L5.0
●	●	ZTER/L-A2525M-DGN2-17	25	25	25	150	2	17	HTM6x25L	
●	●	ZTER/L-A2020K-DGN3-20	20	20	20	125	3	20	HTM6x20L	
●	●	ZTER/L-A2525M-DGN3-20	25	25	25	150	3	20	HTM6x25L	



●:庫存 In Stock    ○:非標準庫存(請確認交貨期) Non-standard Stock

刀片 Insert : ISCAR

# Zy 外徑出水切槽刀 自動車床用

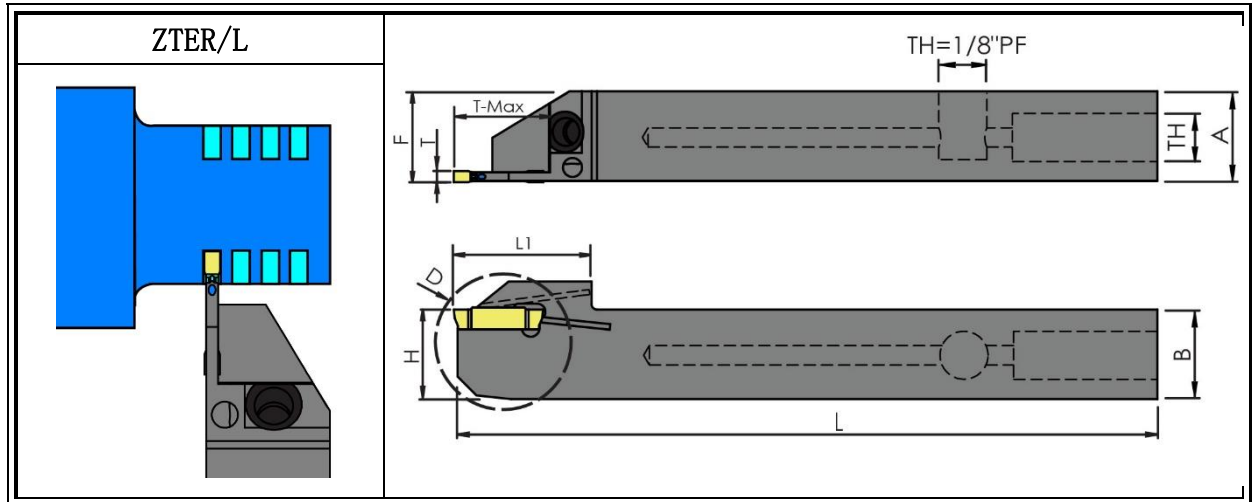

External Grooving With  
Coolant For Automatic Lathes



Stock		型號 Model No.	D	A	B=H	L	L1	T	T-Max	 螺絲 Screw	 板手 Wrench
R	L										
●	●	ZTER/L-A1010K-MGX20A-10	20	10	10	125	18	2	10.5	M4x12.0x5.6	T15
●	●	ZTER/L-A1212K-MGX20A-12.5	25	12	12	125	19.5		13		
●	●	ZTER/L-A1616K-MGX20A-16	32	16	16	125	25		16.5	M4x16.1x5.4	



●:庫存 In Stock ○:非標準庫存(請確認交貨期) Non-standard Stock

刀片 Insert : KORLOY

Stock		型號 Model No.	D	A	B=H	L	L1	T	T-Max	 螺絲 Screw	 板手 Wrench
R	L										
●	●	ZTER/L-A1212K-TD2SH-24	24	12	12	125	19	2	12	M4x16.1x5.4	T15
●	●	ZTER/L-A1616K-TD2SH-32	32	16	16	125	24		16		

●:庫存 In Stock ○:非標準庫存(請確認交貨期) Non-standard Stock

刀片 Insert : Taegu Tec

Stock		型號 Model No.	D	A	B=H	L	L1	T	T-Max	 螺絲 Screw	 板手 Wrench
R	L										
●	●	ZTER/L-A1212K-DGN2-12.5	12.5	12	12	125	19.5	2	12	M4x16.1x5.4	T15
●	●	ZTER/L-A1616K-DGN2-16	16	16	16	125	25		16		

●:庫存 In Stock ○:非標準庫存(請確認交貨期) Non-standard Stock

刀片 Insert Insert ISCAR

# Zy 外徑出水牙刀 External Threading With Coolant

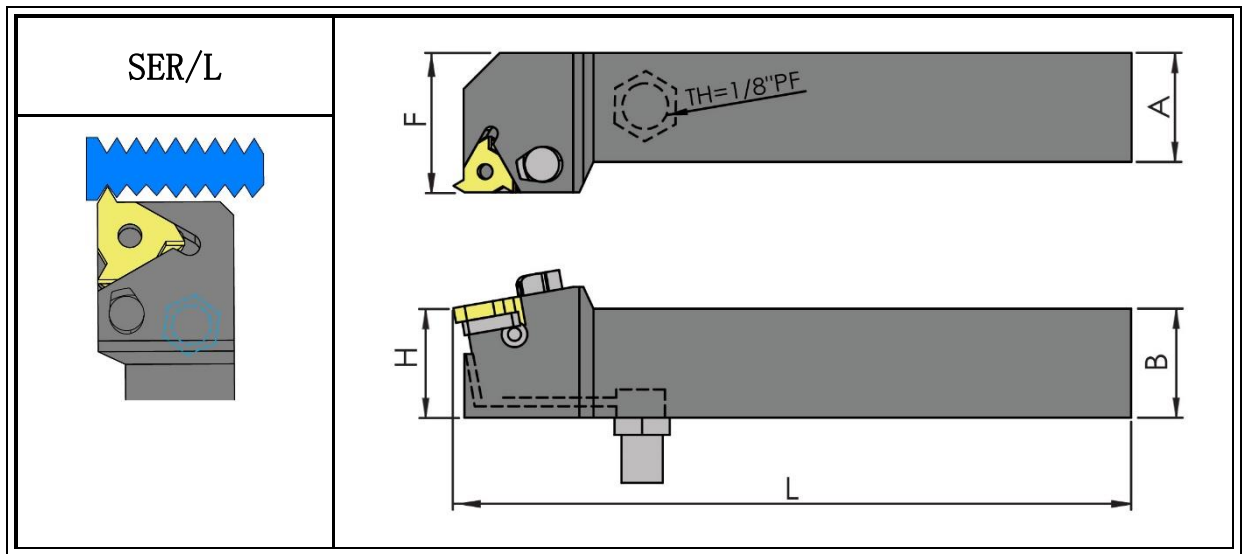

Stock	型號 Model No.	A	B	F	L	螺絲 Screw	墊片 Shim	螺絲 Shim Screw	板手 Wrench	刀片 Insert
●	SER/L-A2020K-16	20	20	25	125	M3. 5x11. 4x5. 1	GXE16	M3	T15	16NR
●	SER/L-A2525M-16	25	25	32	150		GXN16		L:2.5	

●:庫存 In Stock    ○:非標準庫存(請確認交貨期) Non-standard Stock

# Zy 外徑出水牙刀 自動車床用

External Threading With  
Coolant For Automatic Lathes

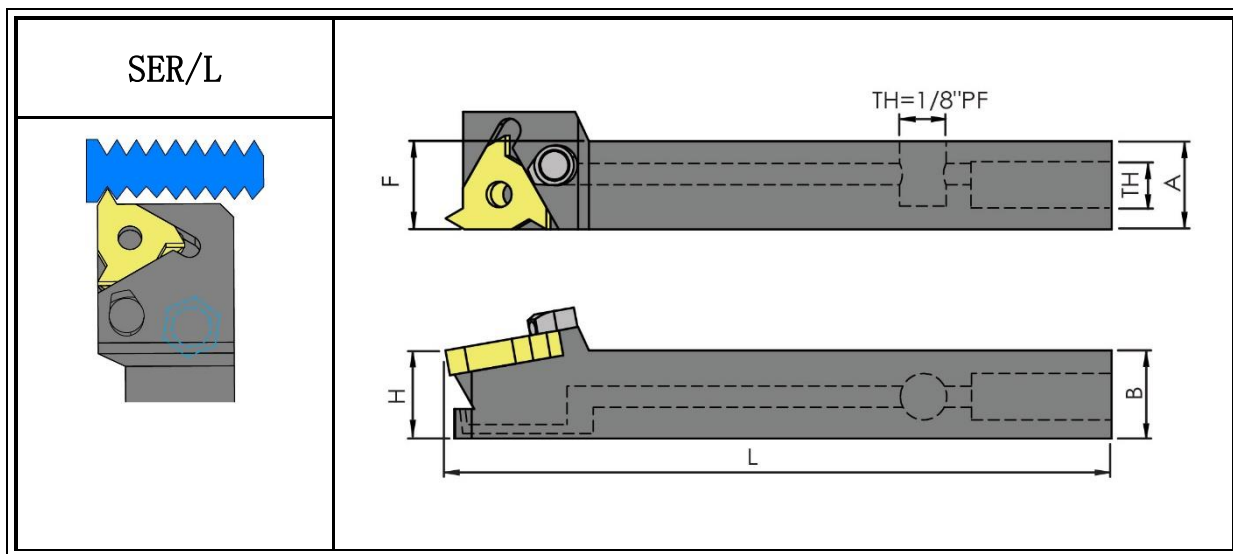

Stock	型號 Model No.	A	B	F	L	螺絲 Screw	墊片 Shim	螺絲 Shim Screw	板手 Wrench	刀片 Insert
●	SER/L-A2020K-16	20	20	25	125	M3. 5x11. 4x5. 1	GXE16	M3	T15	16NR
●	SER/L-A2525M-16	25	25	32	150		GXN16		L:2.5	

●:庫存 In Stock    ○:非標準庫存(請確認交貨期) Non-standard Stock





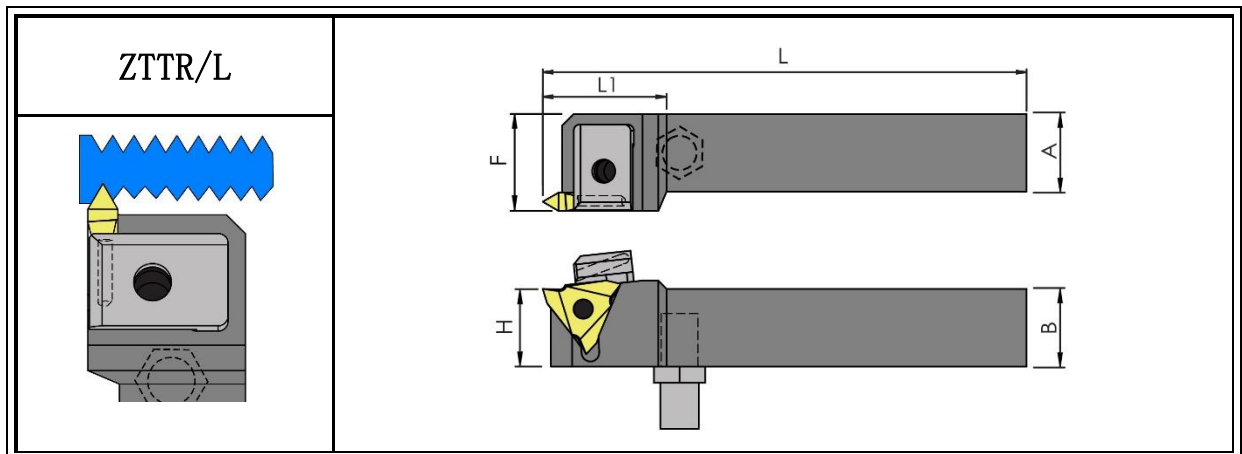



# Zy 外徑出水牙刀 External Threading With Coolant

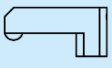

Stock	型號 Model No.	A	B	F	L	刀片 Insert
●	ZTTR/L-A2020K-22	20	20	25	125	三菱 MTTR436002
●	ZTTR/L-A2525M-22	25	25	32	150	

●:庫存 In Stock    ○:非標準庫存(請確認交貨期) Non-standard Stock

## 配件 Tool Parts :

					
壓板 Clamp	中心柱 Clamp Screw	螺絲 Screw	彈簧 Spring	O 型環 O-RING	板手 Wrench
ZMTK1R/L-E	M5x13L	M5x25L	SP5309	4X1	L3

# 外徑車刀



# 外徑車刀架表示方法

## Turning Tool Holders Identification System

A	背面押板緊固方式
C	押板緊固方式
M	雙重緊固方式
P	插銷緊固方式 (槓桿緊固方式)
S	螺絲緊固方式
W	楔型緊固方式
ZS	螺絲緊固方式
刀片緊固方式	

R:圓形
S:90° 四方形
T:60° 三角形
C:80° 菱形
J:70° 菱形
D:55° 菱形
V:35° 菱形
W:80° 不等邊六角形
刀片形狀

R:右手刀 L:左手刀
方向

刀把高度
刀把高度

刀把寬度
刀把寬度

A:32	刀把全長
B:40	
C:50	
D:60	
E:70	
F:80	
G:90	
H:100	
J:110	
K:125	
L:140	
M:150	
N:160	
P:170	
Q:180	
R:200	
S:250	
T:300	
U:350	
V:400	
W:450	
Y:500	
X:特殊	

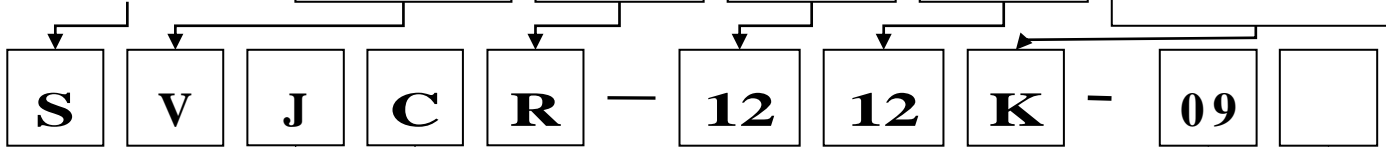

切刃形狀				
A	B	C	D	E
F	G	J	K	L
N	R	S	T	U
W	Y	L2		

刀片後角
B:5° 正角 C:7° 正角 D:15° 正角 E:20° 正角 N:0° 負角 P:11° 正角

切刃長度

任意識別記號或數字
其他



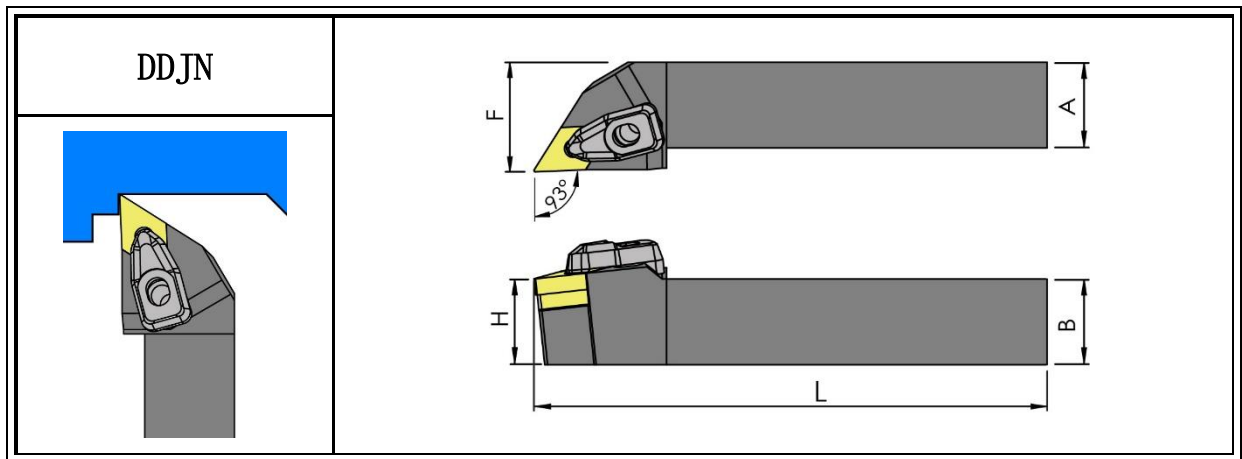

# Zy 外徑車刀 Turning Tools

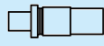

Stock	型號 Model No.	A	B=H	F	L	刀片 Insert
●	DDJNR/L-2020K-15	20	20	25	125	DN1504
●	DDJNR/L-2525M-15	25	25	32	150	

●:庫存 In Stock    ○:非標準庫存(請確認交貨期) Non-standard Stock

## 配件 Tool Parts :

 墊片 Shim	 中心柱 Shim Screw	 壓板 Clamp	 螺絲 Clamp Screw	 彈簧 Spring	 板手 Wrench
DMS442	DDSM4	DDPS-2814	DS625	SP85	L2.5 L3.0



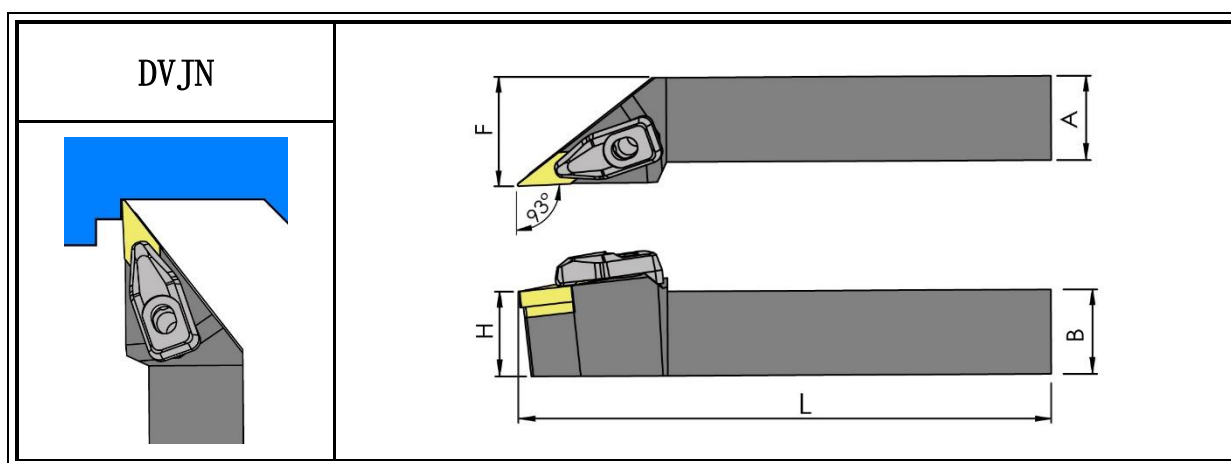

# Zy 外徑車刀 Turning Tools

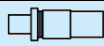

Stock	型號 Model No.	A	B=H	F	L	刀片 Insert
●	DVJNR/L-2020K-16	20	20	25	125	VN1604
●	DVJNR/L-2525M-16	25	25	32	150	

●:庫存 In Stock    ○:非標準庫存(請確認交貨期) Non-standard Stock

## 配件 Tool Parts :

 墊片 Shim	 中心柱 Shim Screw	 壓板 Clamp	 螺絲 Clamp Screw	 彈簧 Spring	 板手 Wrench
GMV322	DVSM4	DVPS-3214	DS625	SP85	L2.5 L3.0



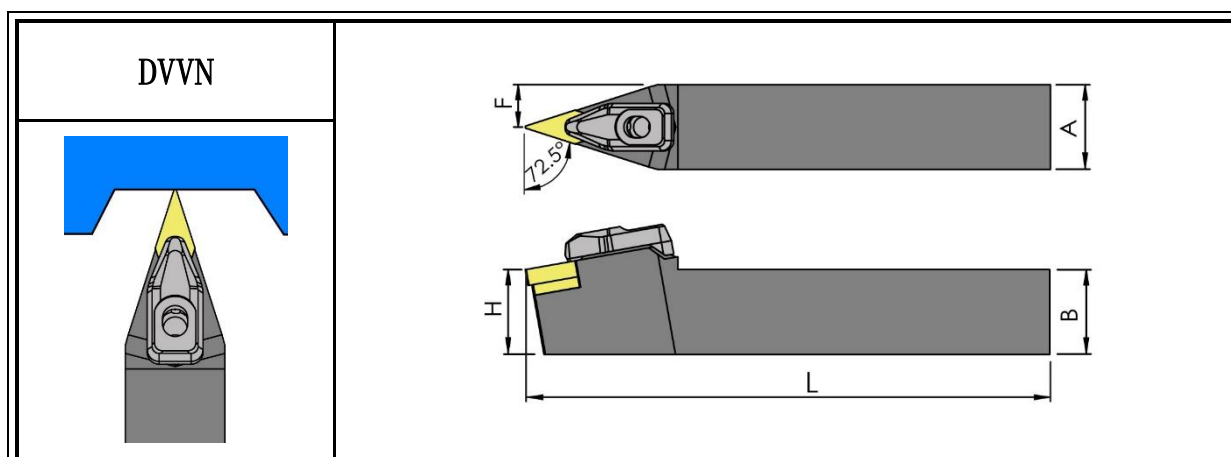

# Zy 外徑車刀 Turning Tools

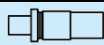

Stock	型號 Model No.	A	B=H	F	L	刀片 Insert
●	DVVN-2020K-16	20	20	25	125	VN1604
●	DVVN-2525M-16	25	25	32	150	

●:庫存 In Stock    ○:非標準庫存(請確認交貨期) Non-standard Stock

## 配件 Tool Parts :

 墊片 Shim	 中心柱 Shim Screw	 壓板 Clamp	 螺絲 Clamp Screw	 彈簧 Spring	 板手 Wrench
GMV322	DVSM4	DVPS-3214	DS625	SP85	L2.5 L3.0



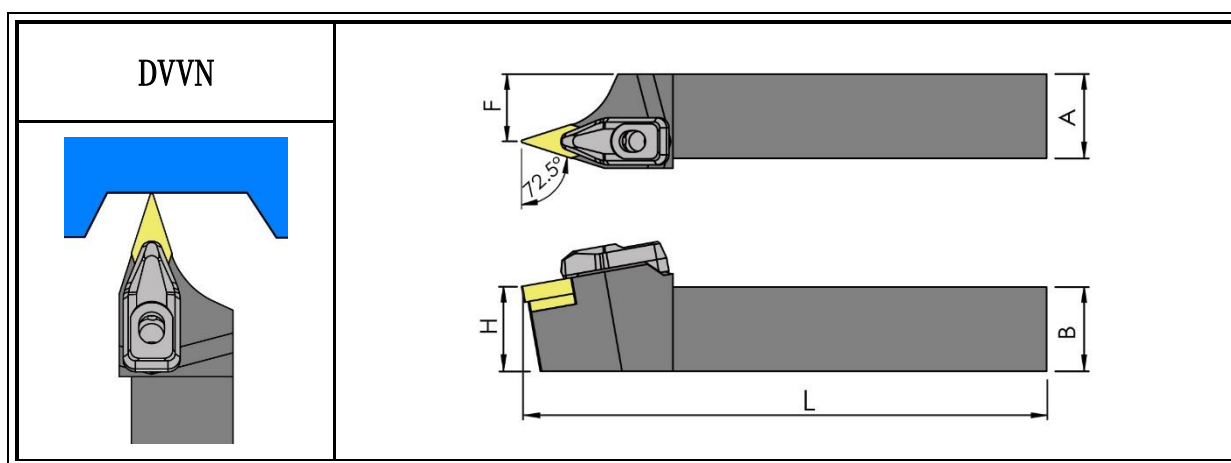

# Zy 外徑車刀 Turning Tools



Stock	型號 Model No.	A	B=H	F	L	刀片 Insert
●	DVVNR/L-2020K-16	20	20	25	125	VN1604
●	DVVNR/L-2525M-16	25	25	32	150	

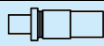

●:庫存 In Stock    ○:非標準庫存(請確認交貨期) Non-standard Stock

## 配件 Tool Parts :

 墊片 Shim	 中心柱 Shim Screw	 壓板 Clamp	 螺絲 Clamp Screw	 彈簧 Spring	 板手 Wrench
GMV322	DVSM4	DVPS-3214	DS625	SP85	L2.5 L3.0

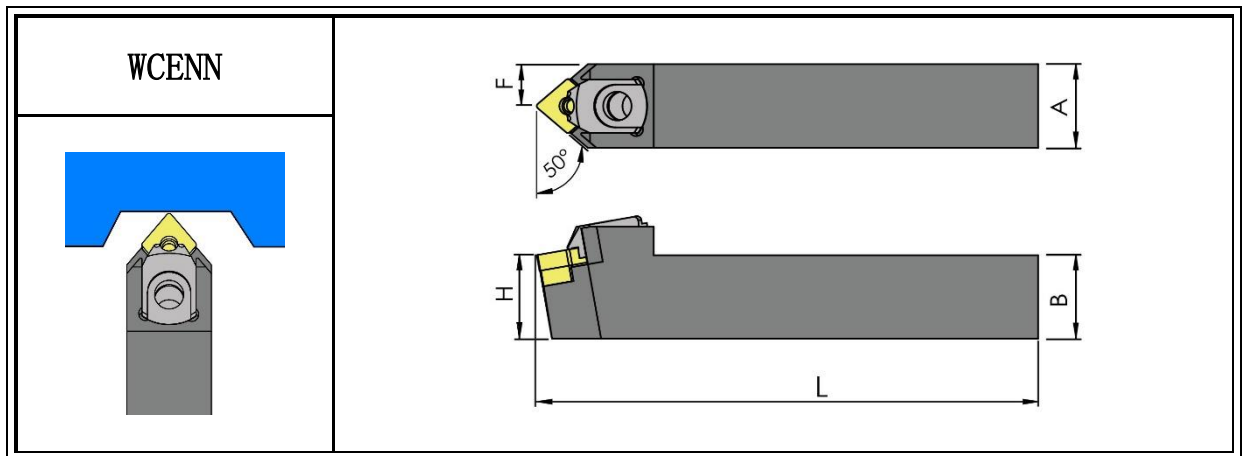

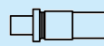

# Zy 外徑車刀 Turning Tools

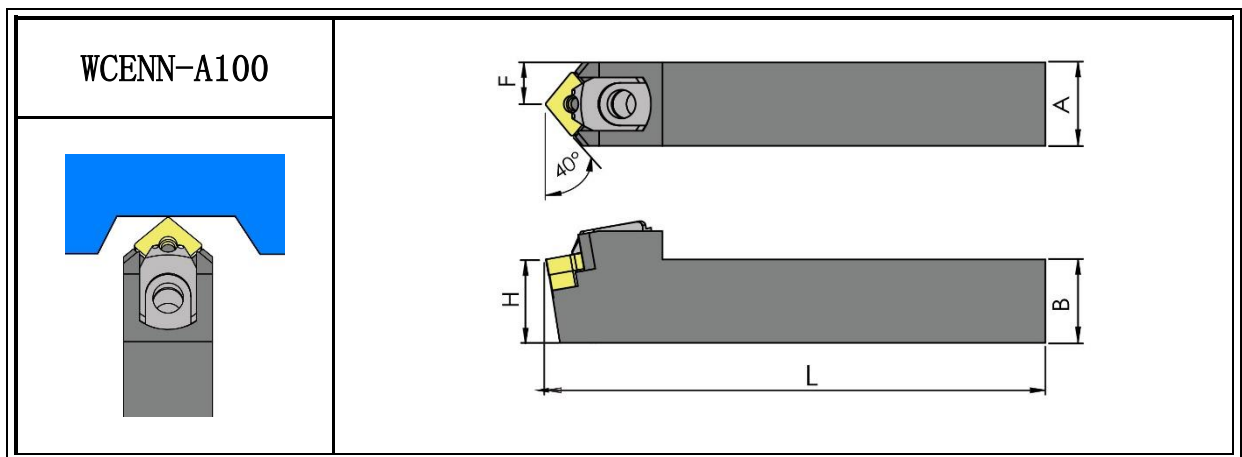

Stock	型號 Model No.	A	B=H	F	L	 墊片 Shim	 中心柱 Shim Screw	 W 型壓板組 W Type Clamp	 板手 Wrench	刀片 Insert
●	WCENN-2020K-12	20	20	10	125	CMS422	LCS-618A	WCPS-2516A	L3.0	CN1204
●	WCENN-2525M-12	25	25	12.5	150				L4.0	

●:庫存 In Stock    ○:非標準庫存(請確認交貨期) Non-standard Stock



Stock	型號 Model No.	A	B=H	F	L	 墊片 Shim	 中心柱 Shim Screw	 W 型壓板組 W Type Clamp	 板手 Wrench	刀片 Insert
●	WCENN-2020K-12-A100	20	20	10	125	CMS422	LCS-618A	WCPS-2516A	L3.0	CN1204
●	WCENN-2020K-12-A100	25	25	12.5	150				L4.0	

●:庫存 In Stock    ○:非標準庫存(請確認交貨期) Non-standard Stock



# Zy 外徑車刀 Turning Tools

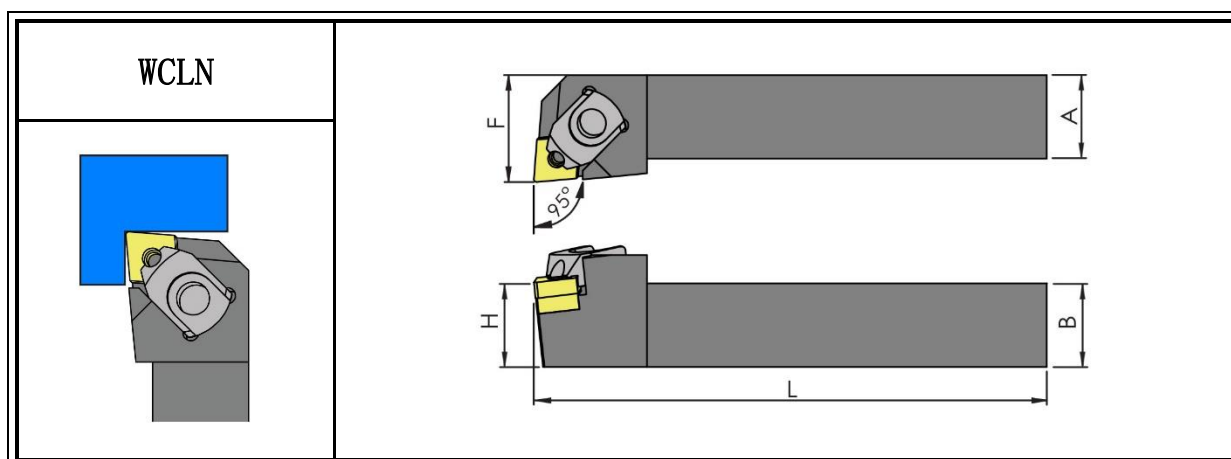

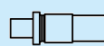
Stock	型號 Model No.	A	B=H	F	L	 墊片 Shim	 中心柱 Shim Screw	 W 型壓板組 W Type Clamp	 板手 Wrench	刀片 Insert
●	WCLNR/L-2020K-12	20	20	10	125	CMS422	LCS-618A	WCPS-2516A	L3.0 L4.0	CN1204
●	WCLNR/L-2525M-12	25	25	12.5	150					

●:庫存 In Stock    ○:非標準庫存(請確認交貨期) Non-standard Stock

# Zy 外徑車刀 Turning Tools

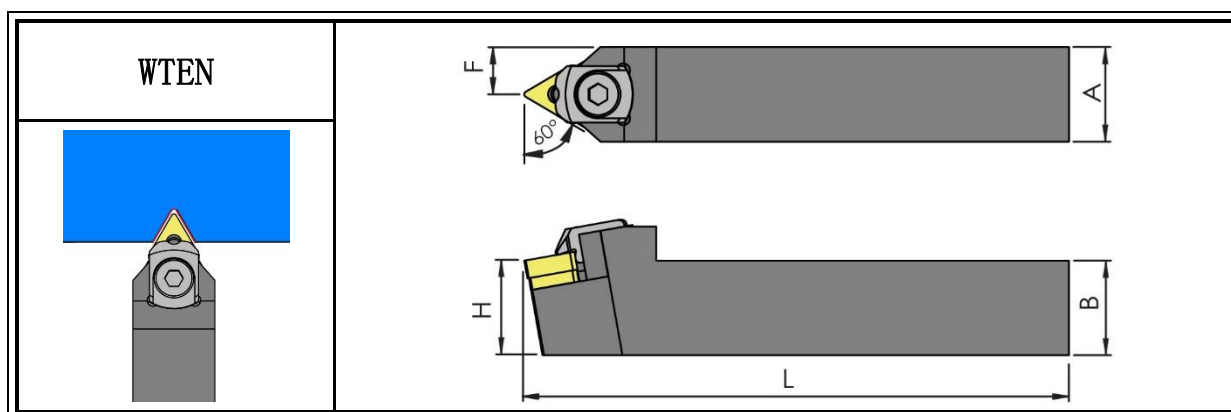

Stock	型號 Model No.	A	B=H	F	L	 墊片 Shim	 中心柱 Shim Screw	 W 型壓板組 W Type Clamp	 板手 Wrench	刀片 Insert
●	WTENN-1616K-16	16	16	8	125	TMS322	LCS-519-1A	WTPS-2115A	L2.5 L4.0	TN1604
●	WTENN-2020K-16	20	20	10	125					
●	WTENN-2525M-16	25	25	12.5	150					
●	WTENN-3232P-16	32	32	16	170					

●:庫存 In Stock    ○:非標準庫存(請確認交貨期) Non-standard Stock

# Zy 外徑車刀 Turning Tools

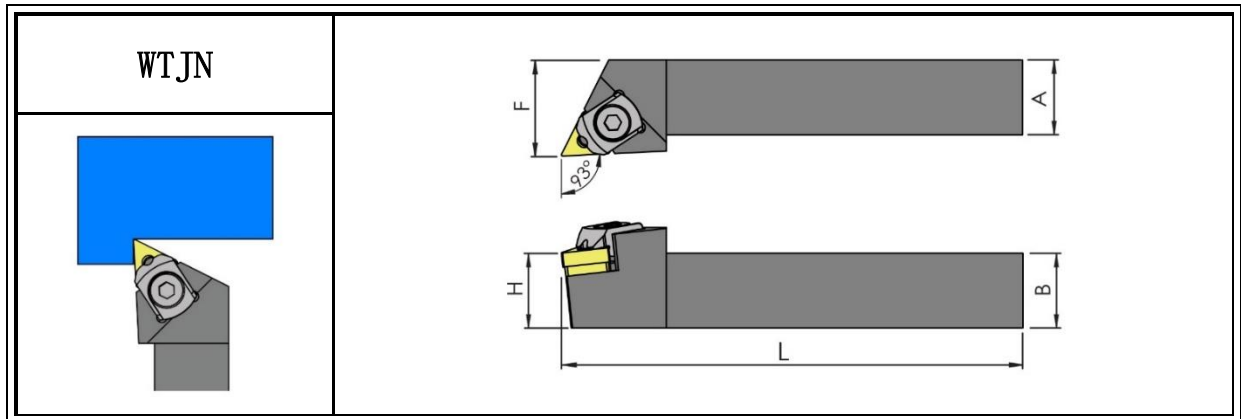

Stock	型號 Model No.	A	B=H	F	L	 墊片 Shim	 中心柱 Shim Screw	 W 型壓板組 W Type Clamp	 板手 Wrench	刀片 Insert
●	WTJNR/L-2020K-16	20	20	25	125	TMS322	LCS-519-1A	WTPS-2115A	L2.5 L4.0	TN1604
●	WTJNR/L-2525M-16	25	25	32	150					
●	WTJNR/L-3232P-16	32	32	40	170					

●:庫存 In Stock    ○:非標準庫存(請確認交貨期) Non-standard Stock

# Zy 外徑車刀 Turning Tools

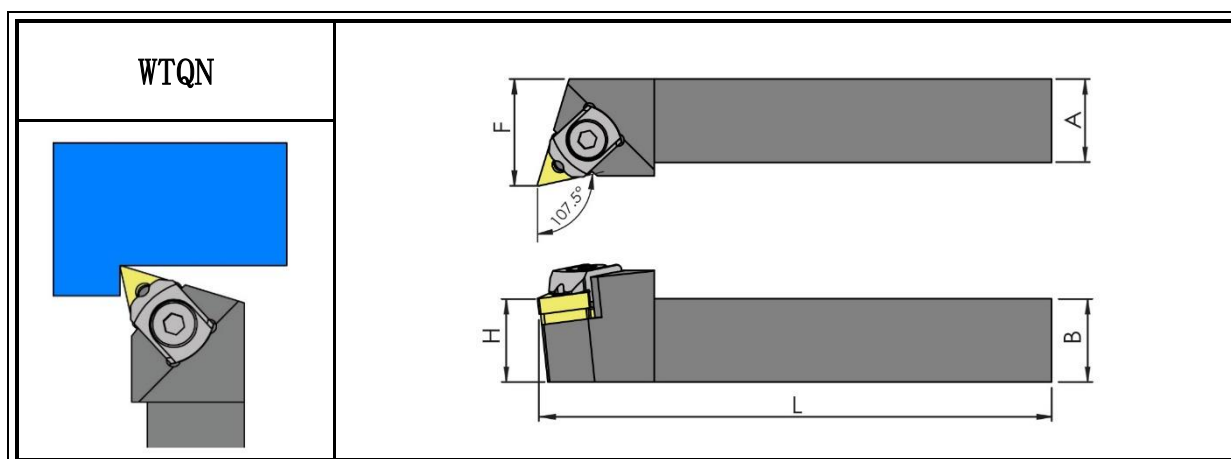

Stock	型號 Model No.	A	B=H	F	L	 墊片 Shim	 中心柱 Shim Screw	 W 型壓板組 W Type Clamp	 板手 Wrench	刀片 Insert
●	WTQNR/L-2020K-16	20	20	25	125	TMS322	LCS-519-1A	WTPS-2115A	L2.5 L4.0	TN1604
●	WTQNR/L-2525M-16	25	25	32	150					

●:庫存 In Stock    ○:非標準庫存(請確認交貨期) Non-standard Stock

# Zy 外徑車刀 Turning Tools

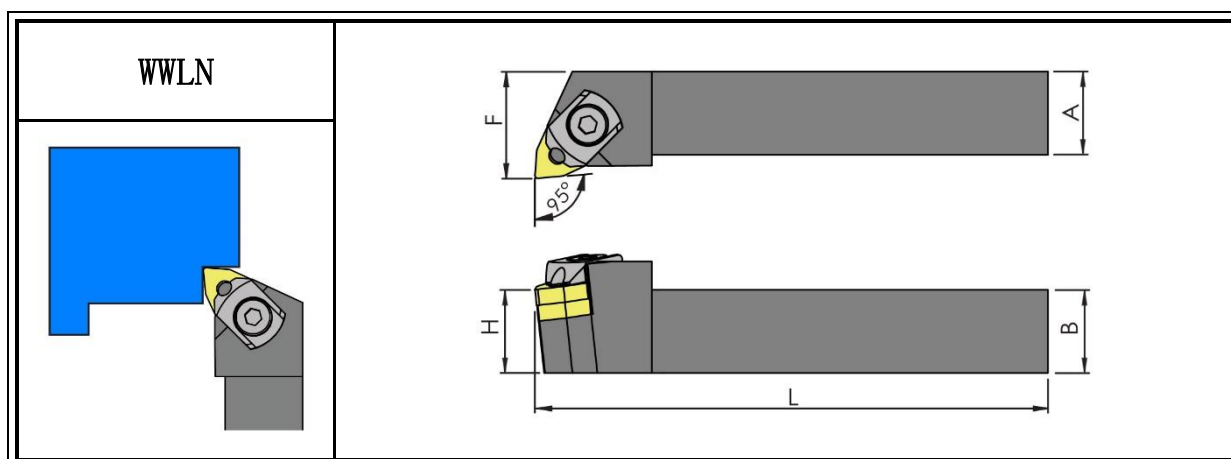

Stock	型號 Model No.	A	B=H	F	L	 墊片 Shim	 中心柱 Shim Screw	 W 型壓板組 W Type Clamp	 板手 Wrench	刀片 Insert
●	WWLNR/L-2020K-08	20	20	25	125	WMS422	LCS-618A	WWPS-2316A	L3.0	WN0804
●	WWLNR/L-2525M-08	25	25	32	150				L4.0	

●:庫存 In Stock    ○:非標準庫存(請確認交貨期) Non-standard Stock

# Zy 外徑車刀 Turning Tools

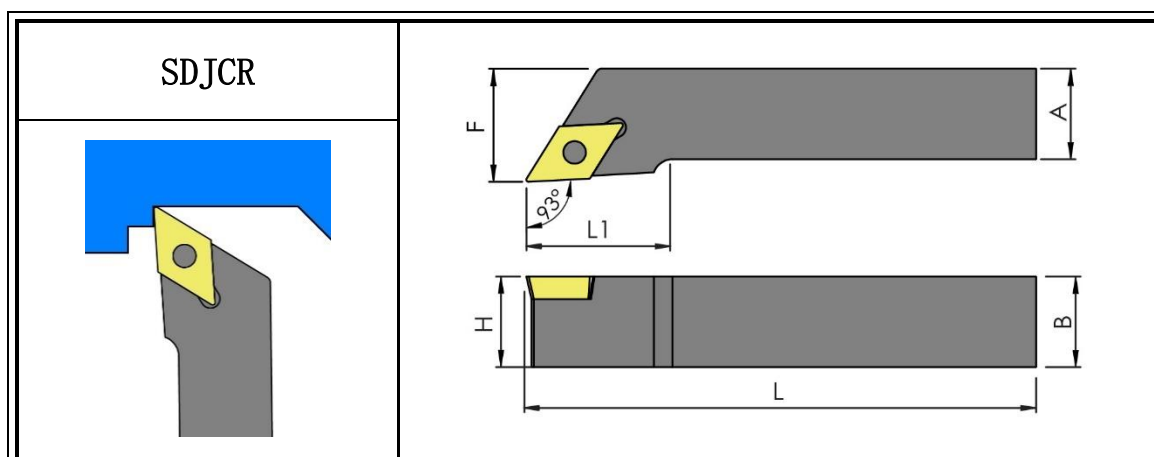

Stock	型號 Model No.	A	B=H	F	L	L1	螺絲 Screw	板手 Wrench	刀片 Insert
●	SDJCR-1010H-07	10	10	12	100	14	M2.5x6.0x3.6	T8	DC0702
○	SDJCR-1212K-07	12	12	16	125	14			
●	SDJCR-1010H-11	10	10	12	100	22	M4x8.8x5.4	T15	DC11T3
●	SDJCR-1212K-11	12	12	16	125	22			
●	SDJCR-1616K-11	16	16	20	125	22			
●	SDJCR-2020K-11	20	20	25	125	22			
●	SDJCR-2525M-11	25	25	32	150	25			

●:庫存 In Stock    ○:非標準庫存(請確認交貨期) Non-standard Stock

# Zy 外徑車刀 Turning Tools

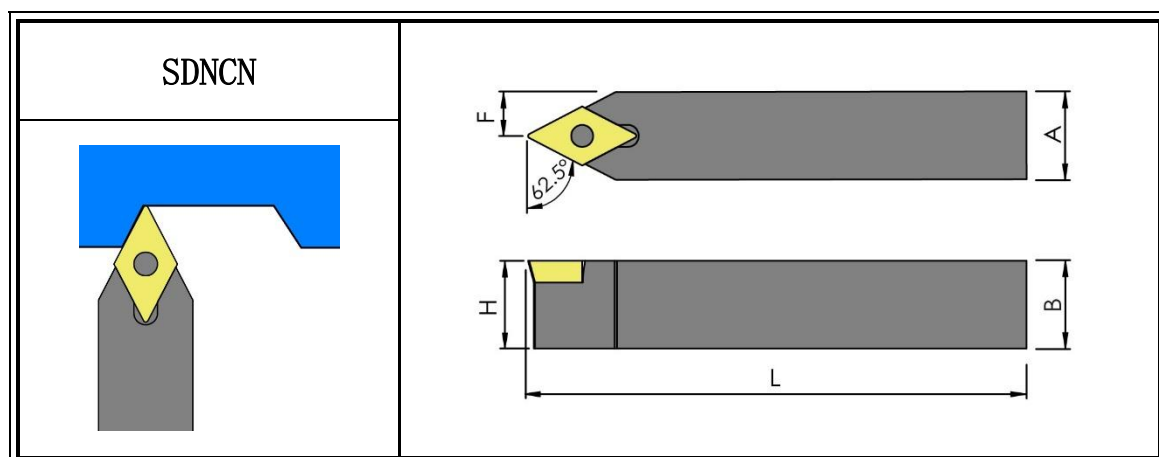

Stock	型號 Model No.	A	B=H	F	L	螺絲 Screw	扳手 Wrench	刀片 Insert
○	SDNCN-0808H-07	8	8	4	100	M2.5x6.0x3.6	T8	DC0702
●	SDNCN-1010H-07	10	10	5	100			
●	SDNCN-1212K-07	12	126	6	125			
●	SDNCN-1212K-11	12	12	6	125	M4x8.8x5.4	T15	DC11T3
●	SDNCN-1616K-11	16	16	8	125			
●	SDNCN-2020K-11	20	20	10	125			
●	SDNCN-2525M-11	25	25	12.5	150			

●:庫存 In Stock    ○:非標準庫存(請確認交貨期) Non-standard Stock

# Zy 外徑車刀 Turning Tools

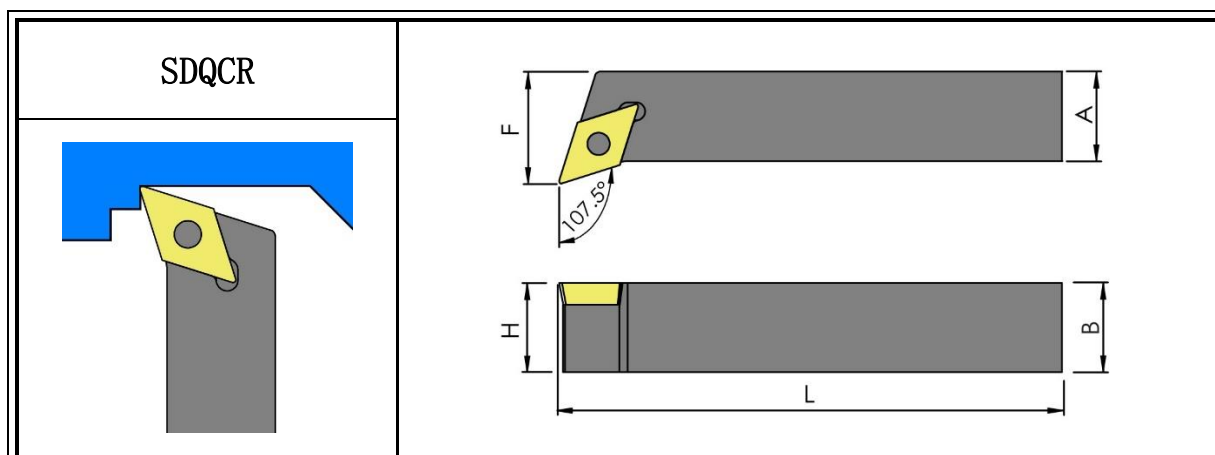



Stock	型號 Model No.	A	B=H	F	L	螺絲 Screw	板手 Wrench	刀片 Insert
●	SDQCR-1010K-07	10	10	12	100	M2.5x6.0x3.6	T8	DC0702
○	SDQCR-1212K-07	12	12	16	125			
●	SDQCR-1212K-11	12	12	16	125	M4x8.8x5.4	T15	DC11T3
●	SDQCR-1616K-11	16	16	20	125			
●	SDQCR-2020K-11	20	20	25	125			
●	SDQCR-2525M-11	25	25	32	150			

●:庫存 In Stock    ○:非標準庫存(請確認交貨期) Non-standard Stock

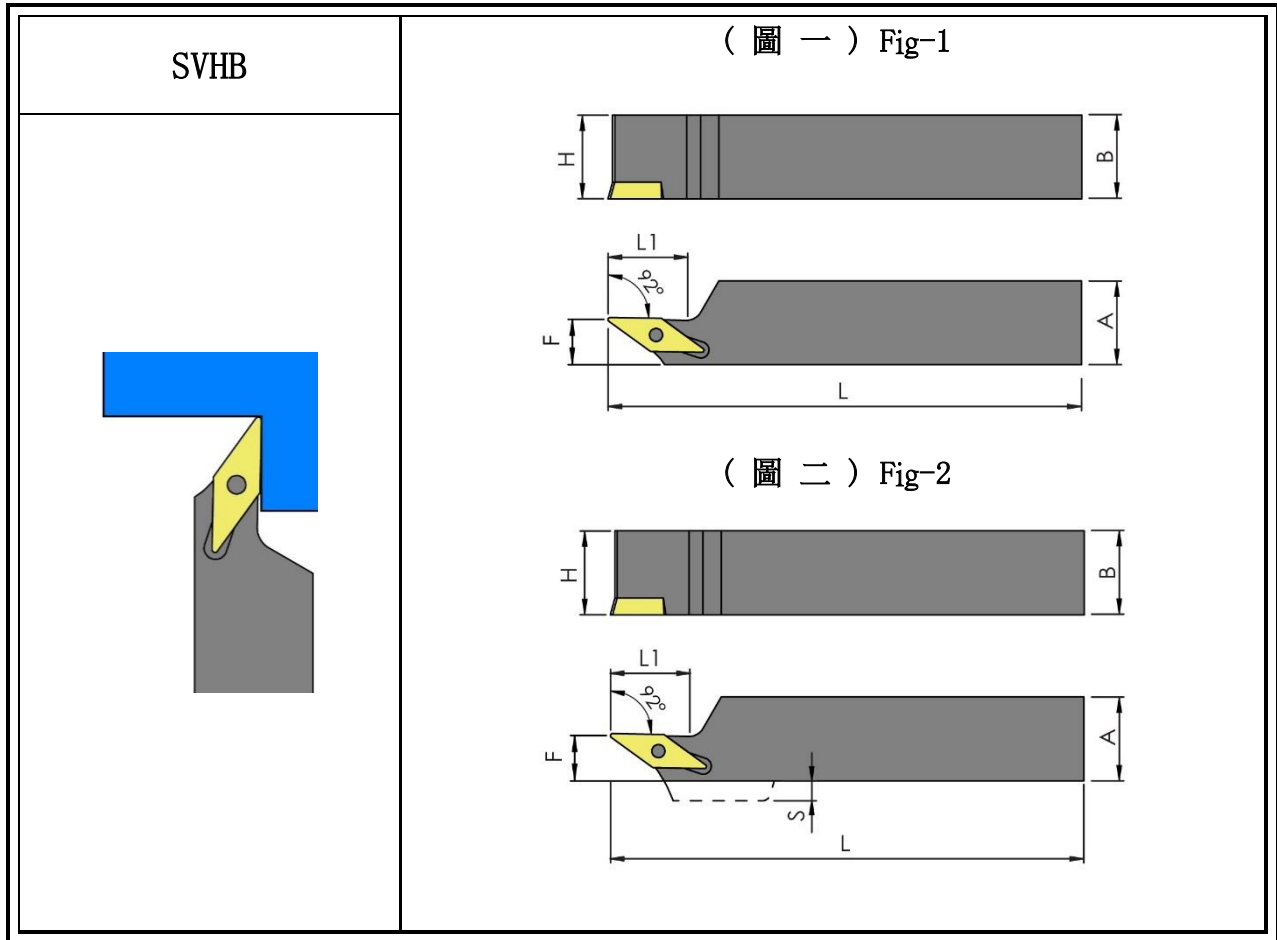

# Zy 外徑車刀 Turning Tools

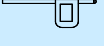

Stock	型號 Model No.	A	B=H	L	L1	S	圖 Fig	 螺絲 Screw	 板手 Wrench	刀片 Insert
●	SVHBL-1010K-11	10	10	125	15	-	1	M2.5x6.0x3.6	T8	VB1103
●	SVHBL-1212K-11	12	12	125	15	-				
●	SVHBL-1616K-11	16	16	125	15	-				
●	SVHBL-2020K-11	20	20	125	19	-				
●	SVHBL-2525M-11	25	25	150	19	-				
●	SVHBL-2525M-11-9.51	25	25	150	19	5	2			

●:庫存 In Stock    ○:非標準庫存(請確認交貨期) Non-standard Stock

# Zy 外徑車刀 Turning Tools

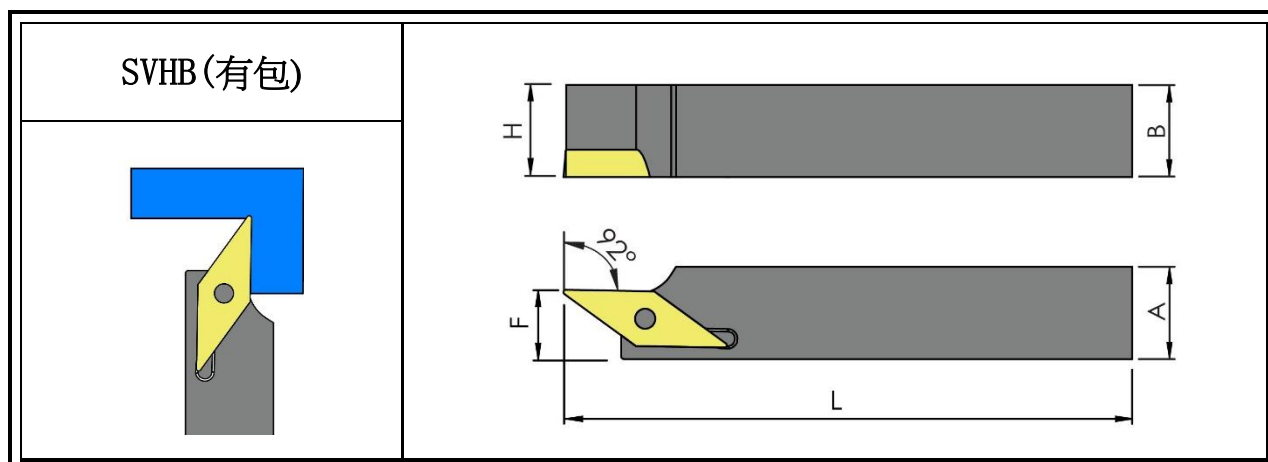

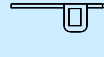
Stock	型號 Model No.	A	B=H	L	F	 螺絲 Screw	 板手 Wrench	刀片 Insert
●	SVHBL-1616K-16ALB	16	16	125	12	M3.5x12.0x5.4	T15	VB1604
●	SVHBL-2020K-16ALB	20	20	125	12			
●	SVHBL-2525M-16ALB	25	25	150	12			

●:庫存 In Stock    ○:非標準庫存(請確認交貨期) Non-standard Stock

# Zy 外徑車刀 Turning Tools

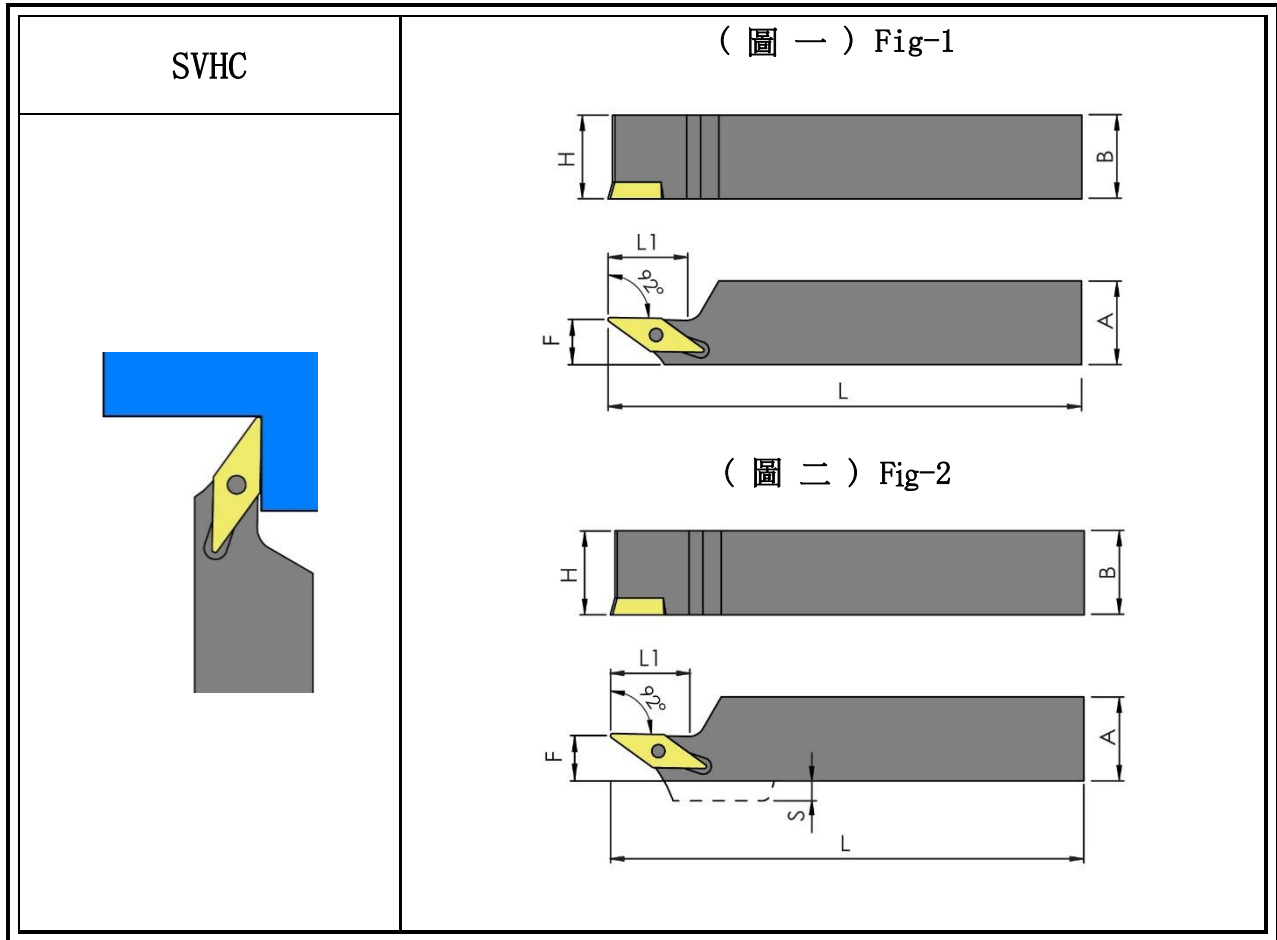

Stock	型號 Model No.	A	B=H	L	L1	S	圖 Fig	螺絲 Screw	扳手 Wrench	刀片 Insert
●	SVHCL-1010K-11	10	10	125	15	-	1	M2. 5x6. 0x3. 6	T8	VC1103
●	SVHCL-1212K-11	12	12	125	15	-				
●	SVHCL-1616K-11	16	16	125	15	-				
●	SVHCL-2020K-11	20	20	125	19	-				
●	SVHCL-2525M-11	25	25	150	19	-				
●	SVHCL-2525M-11-9. 51	25	25	150	19	5	2			

●:庫存 In Stock    ○:非標準庫存(請確認交貨期) Non-standard Stock

# Zy 外徑車刀 Turning Tools

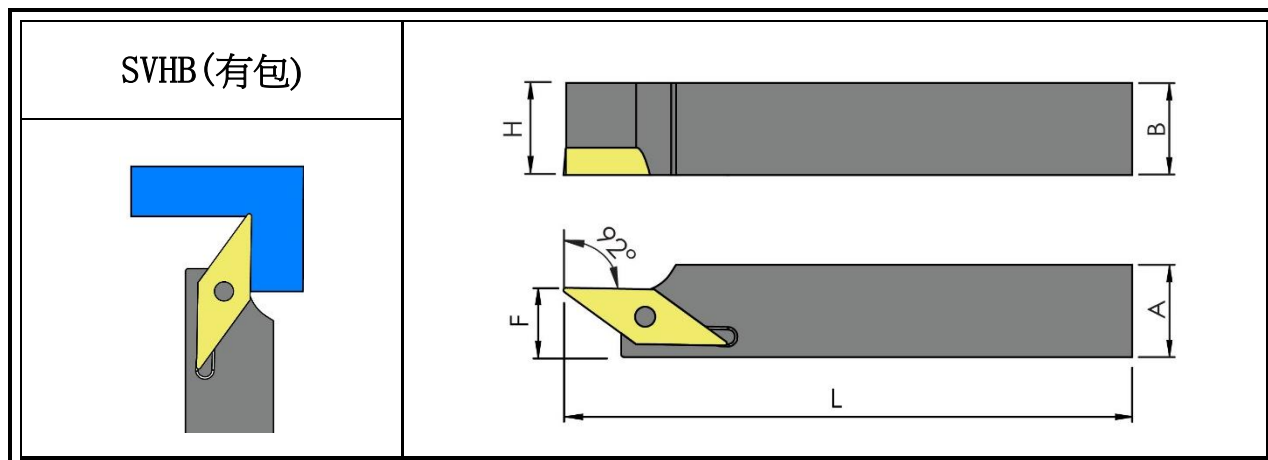



Stock	型號 Model No.	A	B=H	L	F	螺絲 Screw	板手 Wrench	刀片 Insert
●	SVHBL-1616K-16ALB	16	16	125	12	M3.5x12.0x5.4	T15	VB1604
●	SVHBL-2020K-16ALB	20	20	125	12			
●	SVHBL-2525M-16ALB	25	25	150	12			

●:庫存 In Stock    ○:非標準庫存(請確認交貨期) Non-standard Stock

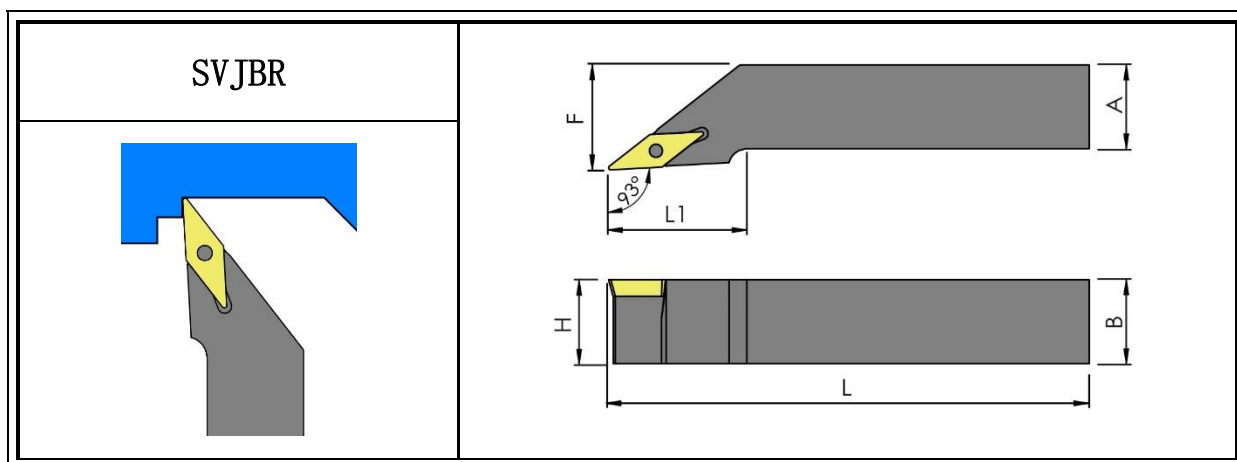
# Zy 外徑車刀 Turning Tools

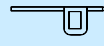

Stock	型號 Model No.	A	B=H	F	L	L1	 墊片 Shim	 墊片螺絲 Shim Screw	 螺絲 Screw	 板手 Wrench	刀片 Insert
●	SVJBR-1010H-11	10	10	12	100	20	-	-	M2.5x6.0x3.6	T8	VB1103
●	SVJBR-1212K-11	12	12	16	125	22					
●	SVJBR-1616K-11	16	16	20	125	22					
●	SVJBR-2020K-11	20	20	25	125	32					
●	SVJBR-2525M-11	25	25	32	150	32					
●	SVJBR-1616K-16	16	16	20	125	32	VSS322	M5	M3.5x11.4x5.7	T15 L:3.5	VB1604
●	SVJBR-2020K-16	20	20	25	125	32					
●	SVJBR-2525M-16	25	25	32	150	32					

●:庫存 In Stock    ○:非標準庫存(請確認交貨期) Non-standard Stock

# Zy 外徑車刀 Turning Tools

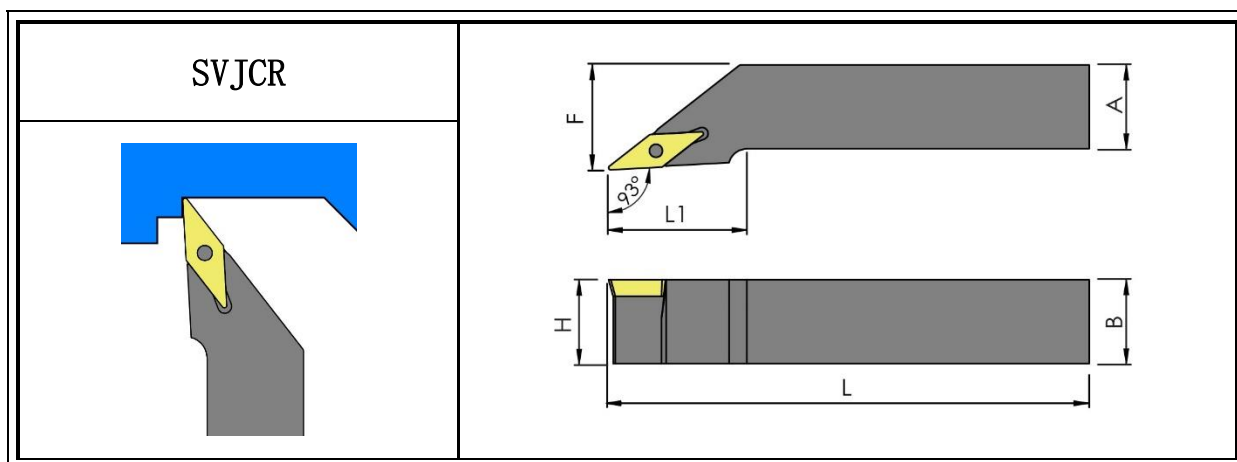

Stock	型號 Model No.	A	B=H	F	L	L1	墊片 Shim	墊片螺絲 Shim Screw	螺絲 Screw	板手 Wrench	刀片 Insert
●	SVJCR-1010H-11	10	10	12	100	20	-	-	M2.5x6.0x3.6	T8	VC1103
●	SVJCR-1212K-11	12	12	16	125	22					
●	SVJCR-1616K-11	16	16	20	125	22					
●	SVJCR-2020K-11	20	20	25	125	32					
●	SVJCR-2525M-11	25	25	32	150	32					
●	SVJCR-1616K-16	16	16	20	125	32	VSS322	M5	M3.5X11.4X5.7	T15 L:3.5	VC1604
●	SVJCR-2020K-16	20	20	25	125	32					
●	SVJCR-2525M-16	25	25	32	150	32					

●:庫存 In Stock    ○:非標準庫存(請確認交貨期) Non-standard Stock

# Zy 外徑車刀 Turning Tools

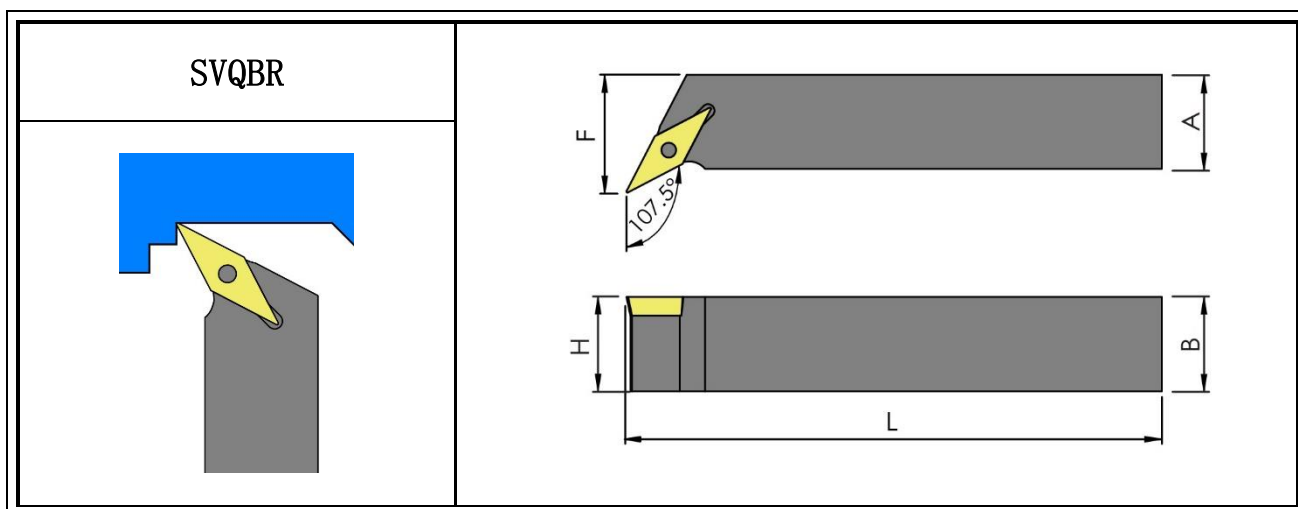

Stock	型號 Model No.	A	B=H	F	L	墊片 Shim	墊片 螺絲 Shim Screw	螺絲 Screw	板手 Wrench	刀片 Insert
●	SVQBR-1212K-11	12	12	16	125					
●	SVQBR-1616K-11	16	16	20	125	-	-	M2.5x6.0x3.6	T8	VB1103
●	SVQBR-2020K-11	20	20	25	125					
●	SVQBR-1616K-16	16	16	20	125			M3.5x12.0x5.4	T15	VB1604
●	SVQBR-2020K-16	20	20	25	125	VSS322	M5	M3.5x11.4x5.7	T15	
●	SVQBR-2525M-16	25	25	32	150				L:3.5	

●:庫存 In Stock    ○:非標準庫存(請確認交貨期) Non-standard Stock

# Zy 外徑車刀 Turning Tools

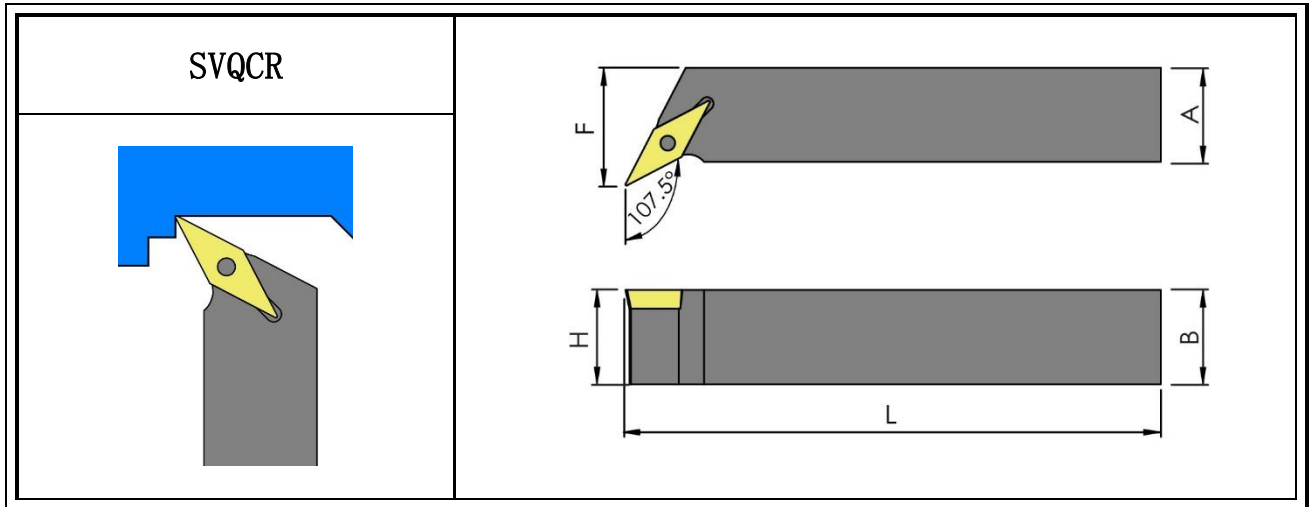

Stock	型號 Model No.	A	B=H	F	L	墊片 Shim	墊片 螺絲 Shim Screw	螺絲 Screw	板手 Wrench	刀片 Insert
●	SVQCR-1212K-11	12	12	16	125	-	-	M2.5x6.0x3.6	T8	VC1103
●	SVQCR-1616K-11	16	16	20	125					
●	SVQCR-2020K-11	20	20	25	125					
●	SVQCR-1616K-16	16	16	20	125	VSS322	M5	M3.5x12.0x5.4	T15	VC1604
●	SVQCR-2020K-16	20	20	25	125					
●	SVQCR-2525M-16	25	25	32	150					

●:庫存 In Stock    ○:非標準庫存(請確認交貨期) Non-standard Stock



# Zy 外徑車刀 Turning Tools

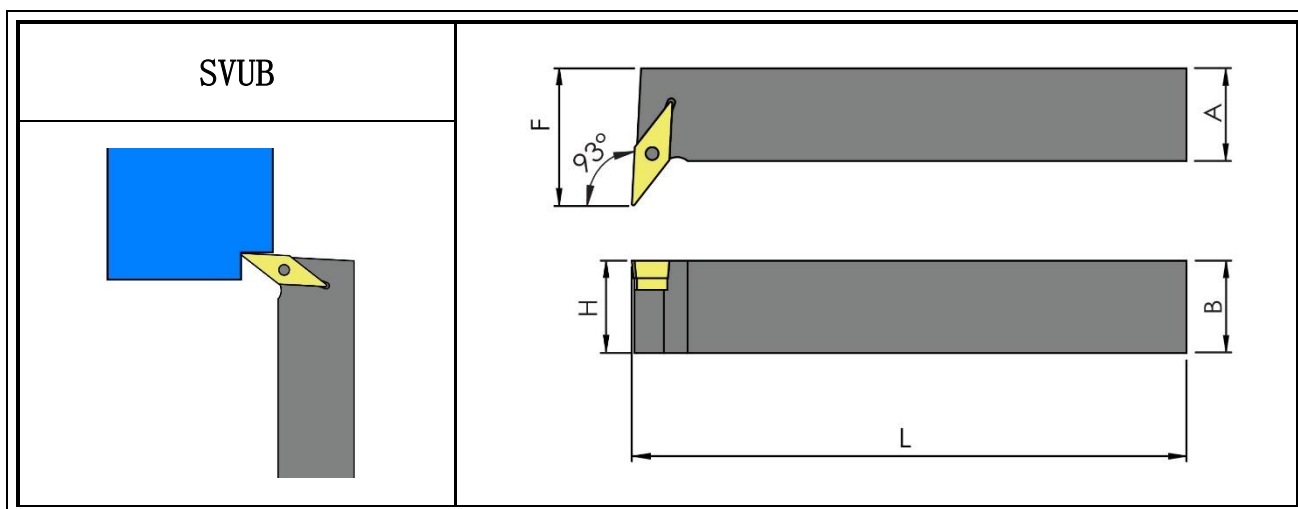

Stock	型號 Model No.	A	B=H	F	L	墊片 Shim	墊片螺絲 Shim Screw	螺絲 Screw	板手 Wrench	刀片 Insert
●	SVUBR/L-2020K-11	20	20	30	125	-	-	M2.5x6.0x3.6	T8	VB1103
●	SVUBR/L-2020K-16	20	20	32	125	VSS322	M5	M3.5x11.4x5.7	T15 L:3.5	VB1604
●	SVUBR/L-2525M-16	25	25	37	150					

●:庫存 In Stock    ○:非標準庫存(請確認交貨期) Non-standard Stock

# Zy 外徑車刀 Turning Tools

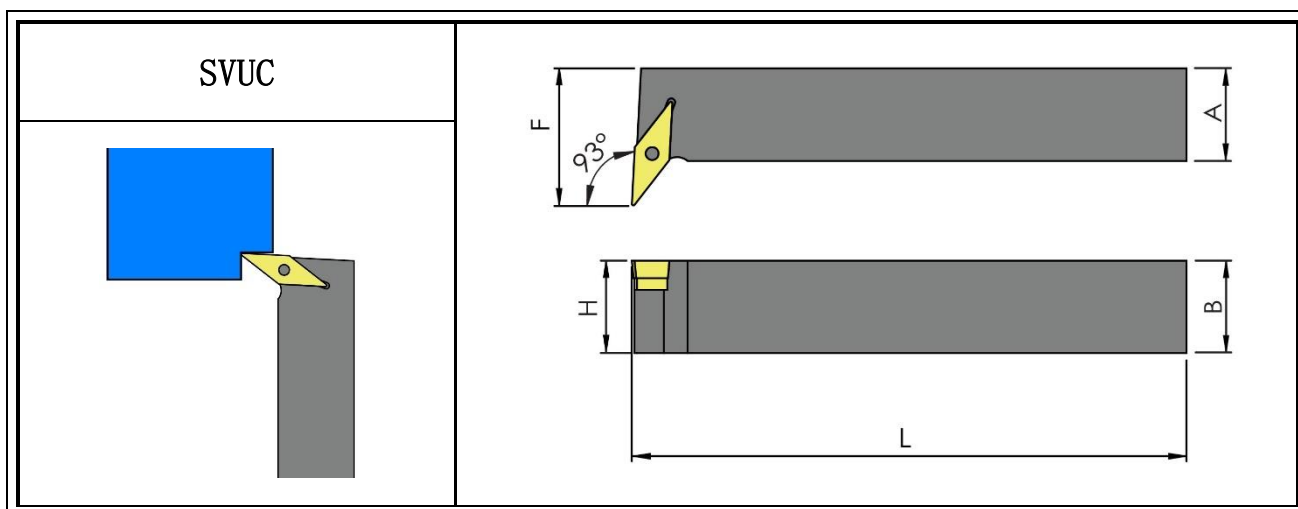

Stock	型號 Model No.	A	B=H	F	L	墊片 Shim	墊片螺絲 Shim Screw	螺絲 Screw	板手 Wrench	刀片 Insert
●	SVUCR/L-2020K-11	20	20	30	125	-	-	M2.5x6.0x3.6	T8	VC1103
●	SVUCR/L-2020K-16	20	20	32	125	VSS322	M5	M3.5x11.4x5.7	T15 L:3.5	VC1604
●	SVUCR/L-2525M-16	25	25	37	150					

●:庫存 In Stock    ○:非標準庫存(請確認交貨期) Non-standard Stock

# Zy 外徑車刀 Turning Tools

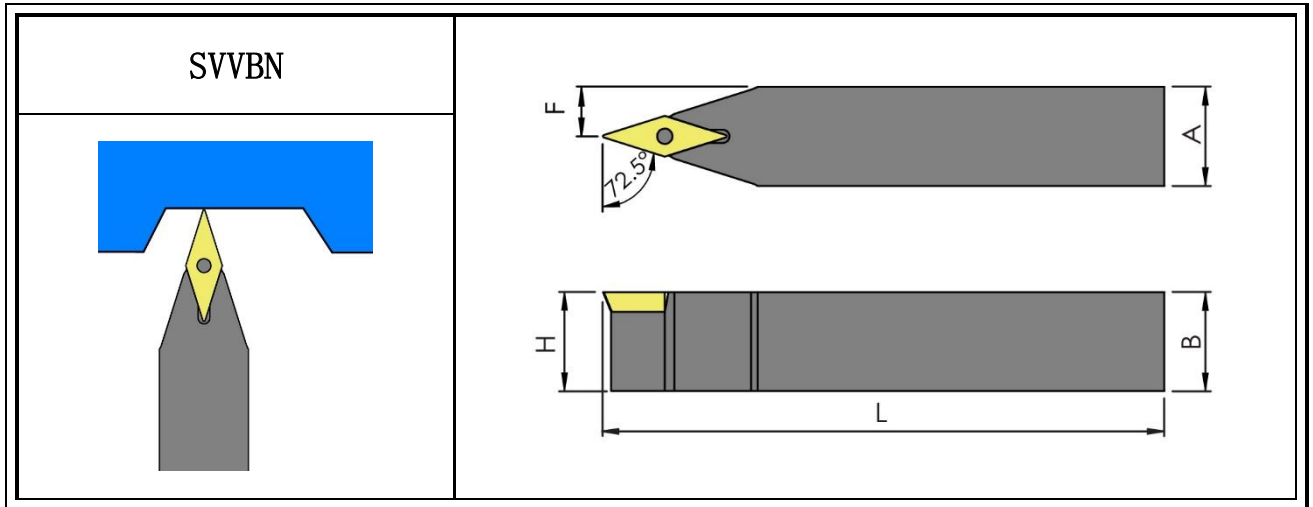

Stock	型號 Model No.	A	B=H	F	L	墊片 Shim	墊片螺絲 Shim Screw	螺絲 Screw	板手 Wrench	刀片 Insert
●	SVVBN-1010H-11	10	10	5	100	-	-	M2.5x6.0x3.6	T8	VB1103
●	SVVBN-1212K-11	12	12	6	125					
●	SVVBN-1616K-11	16	16	8	125					
●	SVVBN-2020K-11	20	20	10	125					
●	SVVBN-2525M-11	25	25	12.5	150					
●	SVVBN-1616K-16	16	16	8	125	VSS322	M5	M3.5x11.4x5.7	T15 L:3.5	VB1604
●	SVVBN-2020K-16	20	20	10	125					
●	SVVBN-2525M-16	25	25	12.5	150					

●:庫存 In Stock    ○:非標準庫存(請確認交貨期) Non-standard Stock

# Zy 外徑車刀 Turning Tools

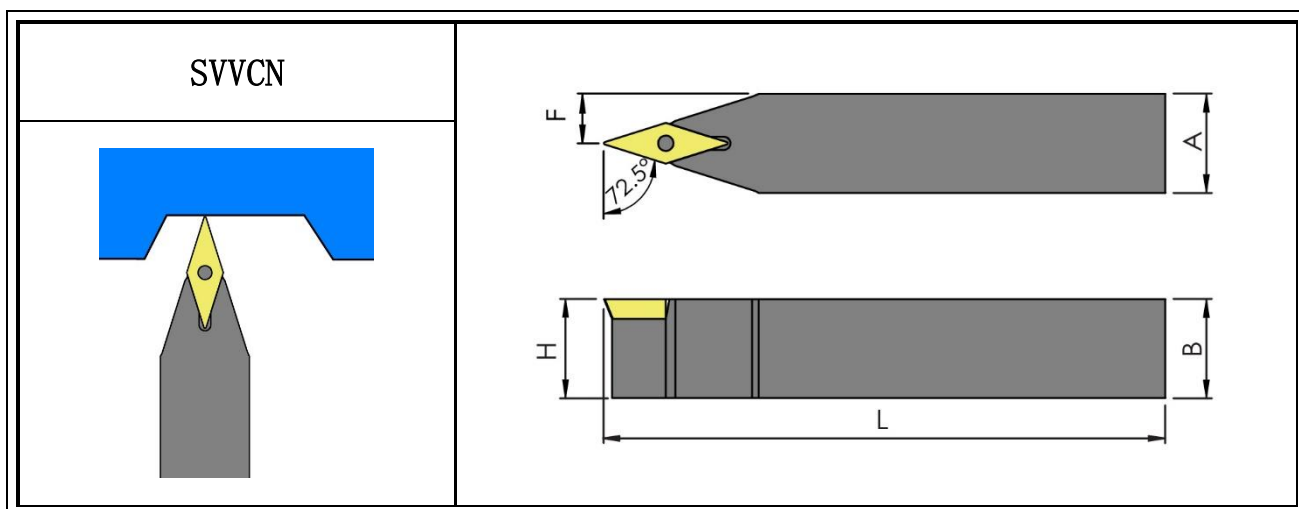



Stock	型號 Model No.	A	B=H	F	L	墊片 Shim	墊片螺絲 Shim Screw	螺絲 Screw	板手 Wrench	刀片 Insert
●	SVVCN-1010H-11	10	10	5	100	-	-	M2.5x6.0x3.6	T8	VC1103
●	SVVCN-1212K-11	12	12	6	125					
●	SVVCN-1616K-11	16	16	8	125					
●	SVVCN-2020K-11	20	20	10	125					
●	SVVCN-2525M-11	25	25	12.5	150					
●	SVVCN-1616K-16	16	16	8	125	VSS322	M5	M3.5x11.4x5.7	T15 L:3.5	VC1604
●	SVVCN-2020K-16	20	20	10	125					
●	SVVCN-2525M-16	25	25	12.5	150					

●:庫存 In Stock    ○:非標準庫存(請確認交貨期) Non-standard Stock

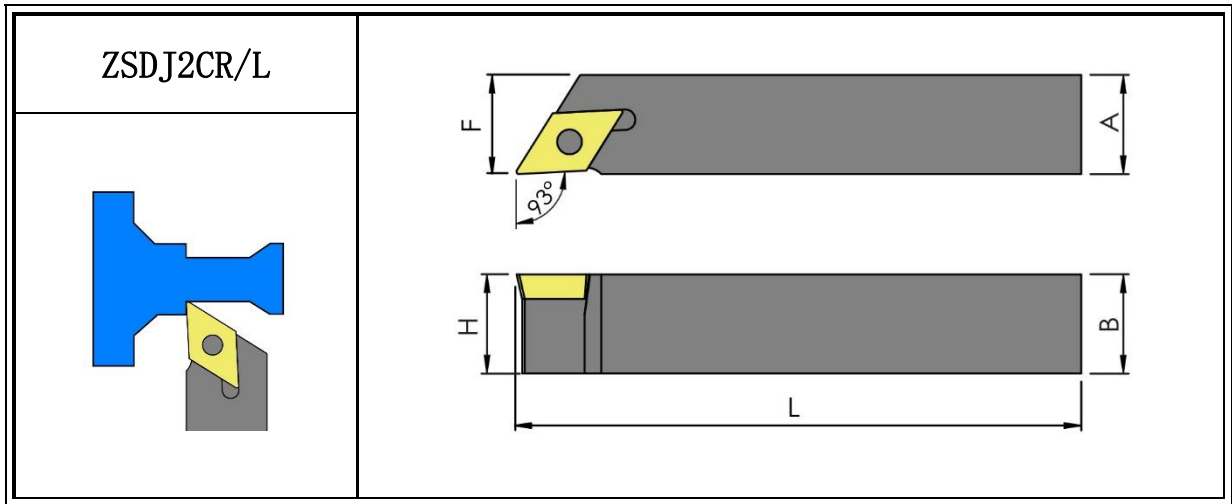
# Zy 外徑車刀-走心式 Tool Holder For Automatic Lathes





Stock		型號 Model No.	A	B=H	F	L	 螺絲 Screw	 板手 Wrench	刀片 Insert
R	L								
●	●	ZSDJ2CR-1010H-07	10	10	10	100	M2.5x6.0x3.6	T8	DC0702
●	○	ZSDJ2CR-1010K-07	10	10	10	125			
●	●	ZSDJ2CR-1212K-07	12	12	12	125			
●	●	ZSDJ2CR-1616K-07	16	16	16	125			
●	○	ZSDJ2CR-2020K-07	20	20	20	125			
●	●	ZSDJ2CR-1010H-11	10	10	10	100	M4x8.8x5.4	T15	DC11T3
●	●	ZSDJ2CR-1212K-11	12	12	12	125			
●	○	ZSDJ2CR-1212K-11AL	12	12	12	125			
●	●	ZSDJ2CR-1616K-11	16	16	16	125			
●	○	ZSDJ2CR-1616K-11AL	16	16	16	125			
●	●	ZSDJ2CR-2020K-11	20	20	20	125			

●:庫存 In Stock    ○:非標準庫存(請確認交貨期) Non-standard Stock

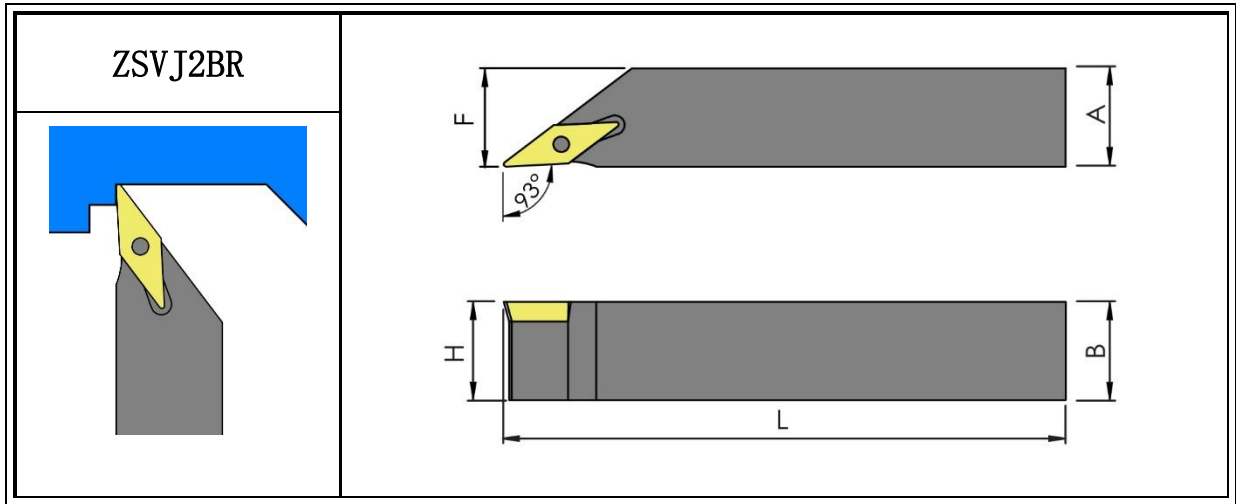
# Zy 外徑車刀-走心式 Tool Holder For Automatic Lathes

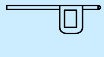

Stock	型號 Model No.	A	B=H	F	L	 墊片 Shim	 墊片螺絲 Shim Screw	 螺絲 Screw	 板手 Wrench	刀片 Insert
●	ZSVJ2BR-1010H-11	10	10	10	100	-	-	M2.5x6.0x3.6	T8	VB1103
●	ZSVJ2BR-1212K-11	12	12	12	125					
●	ZSVJ2BR-1212K-11-A	12	12	12	125					
●	ZSVJ2BR-1616K-11	16	16	16	125					
●	ZSVJ2BR-1616K-16	16	16	16	125	VSS322	M5	M3.5x11.4x5.7	T15	VB16T3
●	ZSVJ2BR-2020K-16	20	20	20	125					

●:庫存 In Stock    ○:非標準庫存(請確認交貨期) Non-standard Stock

# Zy 外徑車刀-走心式 Tool Holder For Automatic Lathes

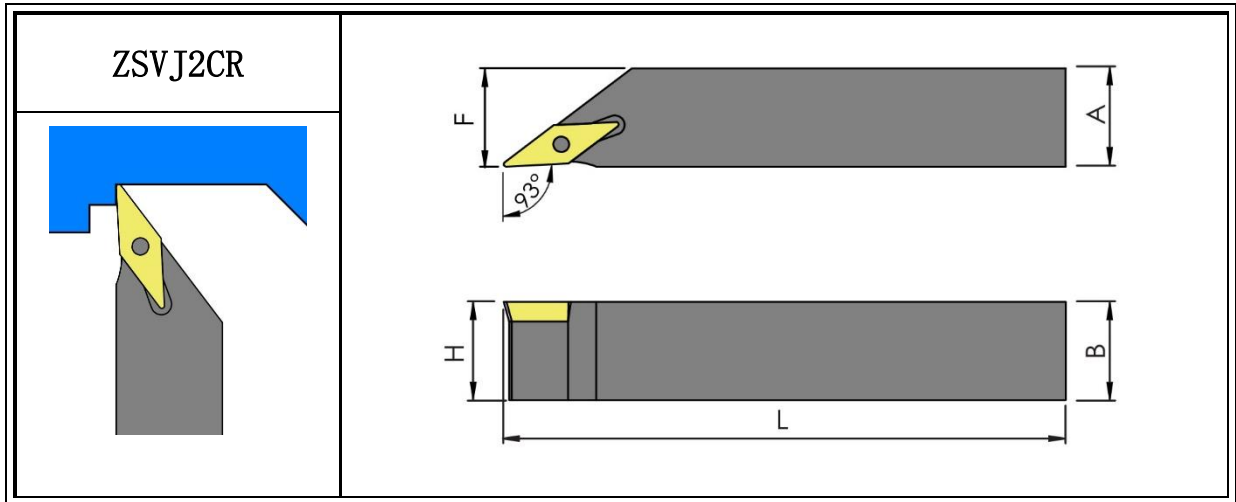

Stock	型號 Model No.	A	B=H	F	L	螺絲 Screw	扳手 Wrench	刀片 Insert
●	ZSVJ2CR-1010H-11	10	10	10	100	M2.5x6.0x3.6	T8	VC1103
●	ZSVJ2CR-1212K-11	12	12	12	125			
●	ZSVJ2CR-1212K-11A	12	12	12	125			
●	ZSVJ2CR-1212K-11-A	12	12	12	125			
●	ZSVJ2CR-1616K-11	16	16	16	125			
●	ZSVJ2BR-1616K-16	16	16	16	125	M3.5x11.4x5.7	T15	VC1604
●	ZSVJ2CR-2020K-16	20	20	20	125	VSS322 菱形刀墊 +M5	L3.5	
●	ZSVJ2CR-2020K-16B	20	20	20	125	M3.5x12.0x5.4	T15	

●:庫存 In Stock    ○:非標準庫存(請確認交貨期) Non-standard Stock

\*ZSVJ2CR-2020K-16B 沒有刀墊

# 切槽刀系列

- 內徑切槽刀
- 內徑端面切槽
- 外徑切槽
- 外徑端面切槽







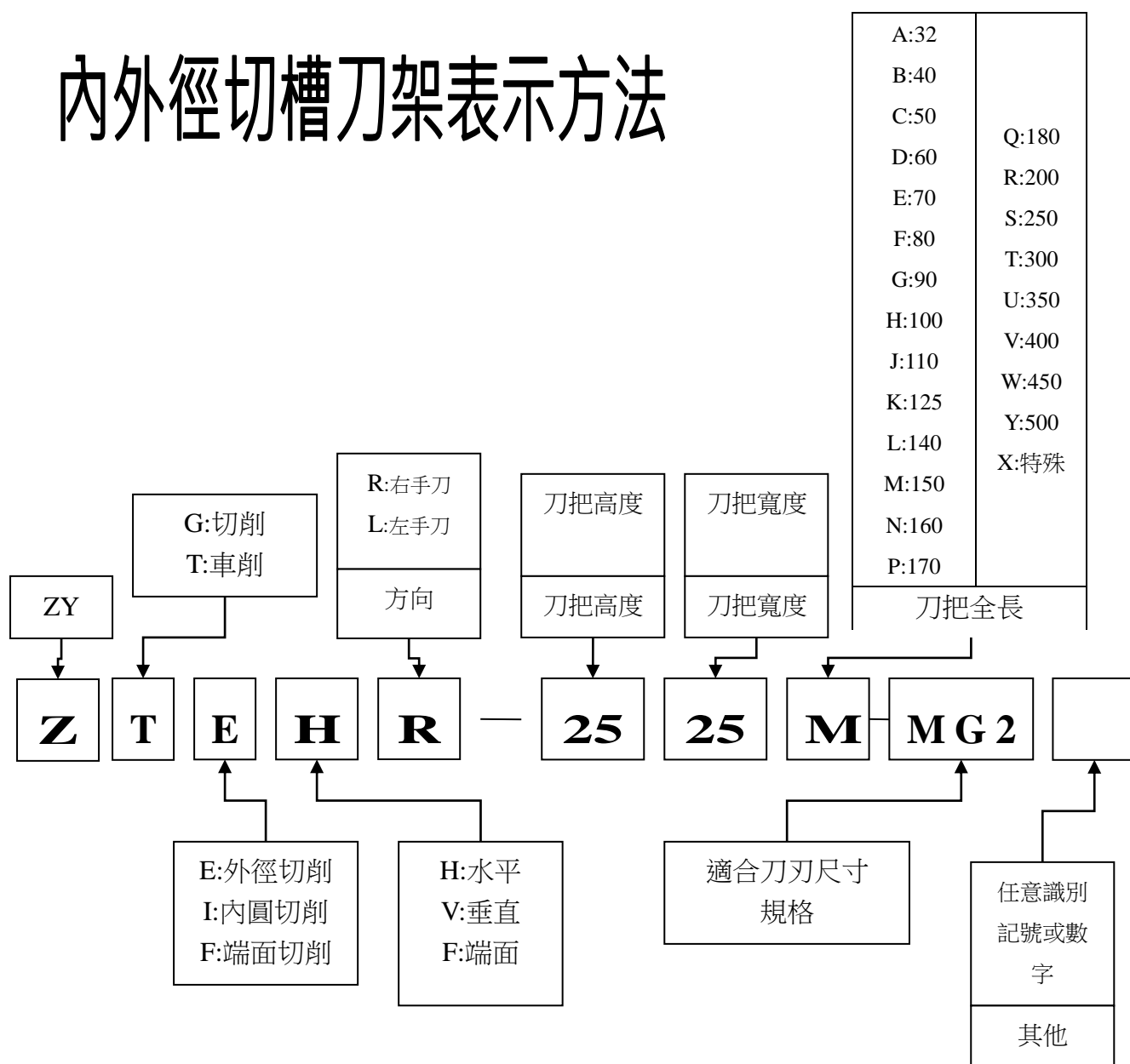

# 內外徑切槽刀架表示方法

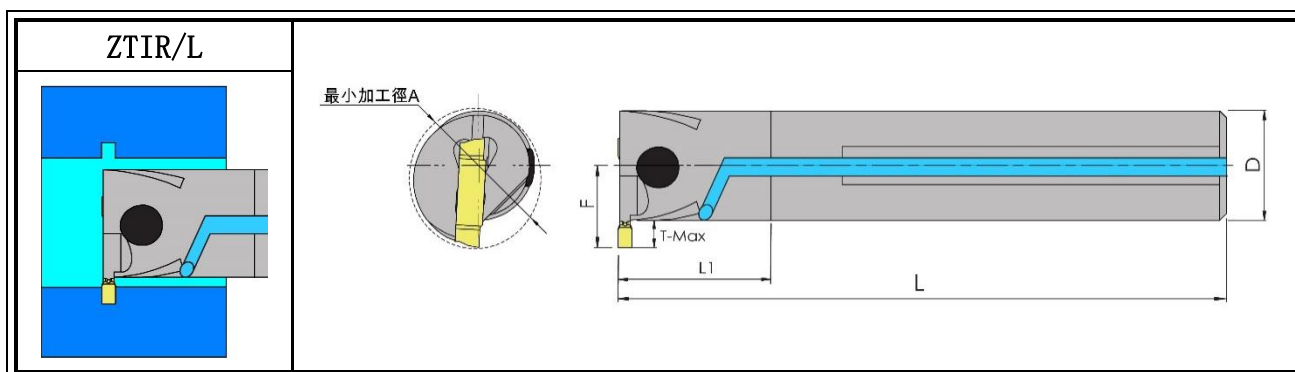

# Zy 內徑切槽刀 Internal Grooving With Coolant



Stock		型號 Model No.	最小加工徑 A	F	D	L	L1	T-Max	 螺絲 Screw	 板手 Wrench
R	L									
●	○	ZTIR/L-2016K-MG2-4	20	12	16	125	25	4	M4-12-5.6-60	T15

Stock		型號 Model No.	最小加工徑	F	D	L	L1	T-Max	 螺絲 Screw	 板手 Wrench
R	L									
○	○	ZTIR/L-2520M-MG2-4	25	14.5	20	150	25	4	HTM5x12L	P4.0
○	○	ZTIR/L-2925R-MG2-4	29	16.5	25	200	30	4		
○	○	ZTIR/L-2620M-MG3-6	26	16	20	150	25	6	HTM5x12L	P4.0
○	○	ZTIR/L-3125R-MG3-6	31	18.5	25	200	30	6		
●	○	ZTIR/L-3832S-MG3-6	38	22	32	250	40	6	HTM5x12L	P4.0
○	○	ZTIR/L-2620M-MG4-6	26	16	20	150	25	6		
○	○	ZTIR/L-3125R-MG4-6	31	18.5	25	200	30	6	HTM5x12L	P4.0
○	○	ZTIR/L-3832S-MG4-6	38	22	32	250	40	6		
○	○	ZTIR/L-3125R-MG5-8	31	19.5	25	200	30	8	HTM6x16L	P5.0
○	○	ZTIR/L-3832S-MG5-6	38	22	32	250	40	6		

●:庫存 In Stock    ○:非標準庫存(請確認交貨期) Non-standard Stock

刀片 Insert : KORLOY

MG2= MG200

MG3= MG300

MG4= MG400

MG5= MG500



# Zy 內徑切槽刀 Internal Grooving With Coolant

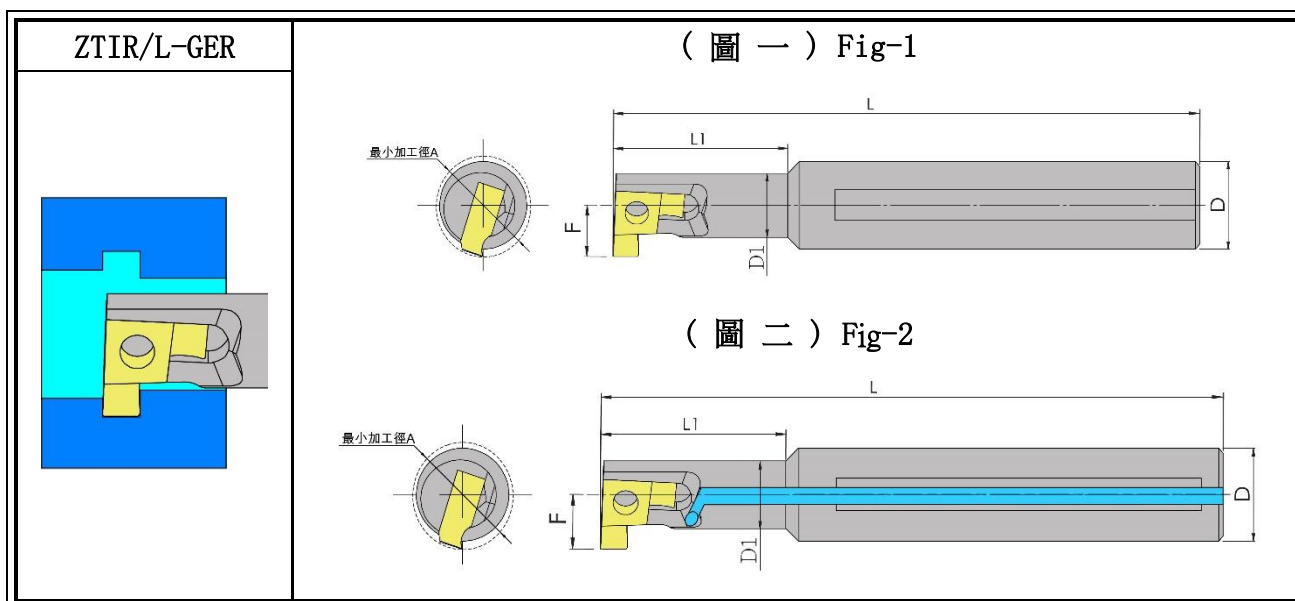

Stock	型號 Model No.	最小加工徑 A	F	D	D1	L	L1	螺絲 Screw	扳手 Wrench	刀片 Insert
鎢鋼柄 (圖一) Carbide Shank (Fig-1)										
○	ZTIR-C0808J-GER-A	8	4.8	8	5.9	110	20	M2. 2x5. 6x3. 3	T7	GER...A
●	ZTIR-C1008K-GER-B	10	5.85	8	7.3	125	15			GER...B
○	ZTIR-C1010K-GER-B	10	6.2	10	7	125	25			
○	ZTIR-C1210K-GER-B	12	7	10	9	125	30			
鎢鋼柄 + 水孔 (圖二) Carbide Shank With Coolant (Fig-2)										
○	ZTIR-E0808J-GER-A	8	4.8	8	5.9	110	20	M2. 2x5. 6x3. 3	T7	GER...A
●	ZTIR-E1008K-GER-B	10	5.85	8	7.3	125	15			GER...B
○	ZTIR-E1010K-GER-B	10	6.2	10	7	125	25			
○	ZTIR-E1210K-GER-B	12	7	10	9	125	30			

●:庫存 In Stock    ○:非標準庫存(請確認交貨期) Non-standard Stock

# Zy 內徑端面切槽刀 Internal Face Grooving With Coolant

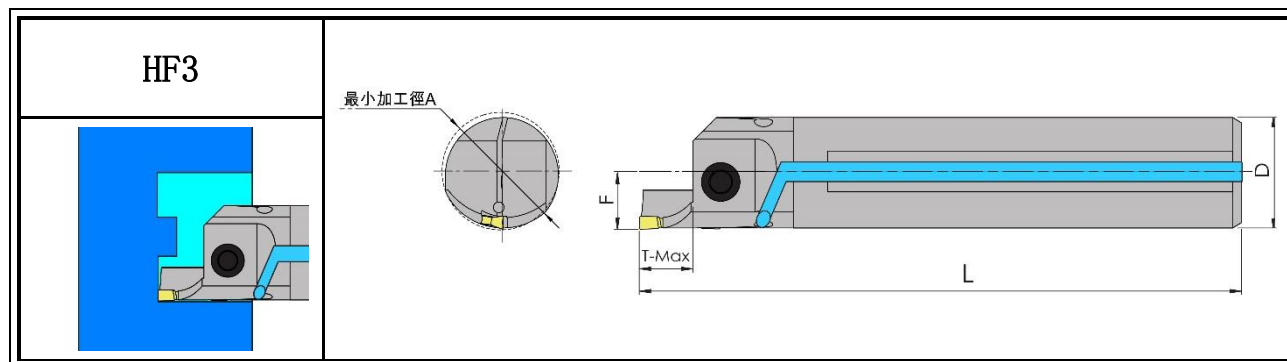

Stock	型號 Model No.	A 最小 A Max	A 最大 A Min	F	D	L	T-Max	螺絲 Screw	板手 Wrench
●	ZTIFR-2530A25M-HF3-12	25	30	13.5	25	150	12	HTM5x16L	P4.0
●	ZTIFR-3038A25M-HF3-12	30	38		25	150			
●	ZTIFR-3848A25M-HF3-12	38	48		25	150			
●	ZTIFR-4860A25M-HF3-12	48	60		25	150			
●	ZTIFR-6075A25M-HF3-22	60	75		25	150	22		
●	ZTIFR-75100A25M-HF3-25	75	100		25	150	25		

●:庫存 In Stock    ○:非標準庫存(請確認交貨期) Non-standard Stock

刀片 Insert : ISCAR

# Zy 內徑端面切槽刀 Internal Face Grooving With Coolant

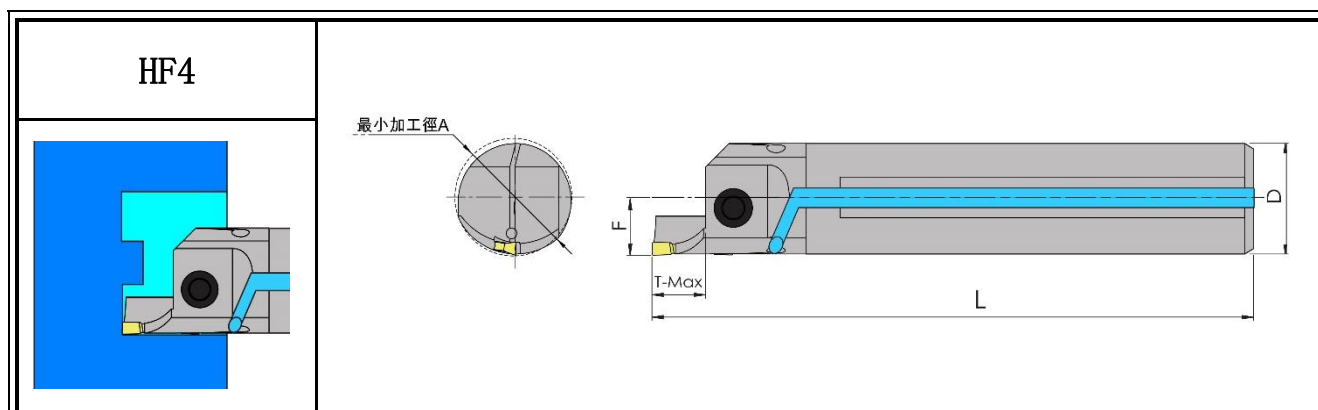

Stock	型號 Model No.	A 最小 A Max	A 最大 A Min	F	D	L	T-Max	螺絲 Screw	扳手 Wrench
●	ZTIFR-2529A25M-HF4-12	25	29	13.5	25	150	12	HTM5x16L	P4.0
●	ZTIFR-2934A25M-HF4-12	29	34		25	150			
●	ZTIFR-3440A25M-HF4-20	34	40		25	150			
●	ZTIFR-4048A25M-HF4-25	40	48		25	150	25		
●	ZTIFR-4860A25M-HF4-25	48	60		25	150			
●	ZTIFR-6075A25M-HF4-25	60	75		25	150			
●	ZTIFR-75100A32R-HF4-25	75	100	17	32	200	25	HTM5x16L	P4.0
●	ZTIFR-100140A32R-HF4-25	100	140		32	200			
●	ZTIFR-140240A32R-HF4-25	140	240		32	200			
●	ZTIFR-240800A32R-HF4-25	240	800		32	200			

●:庫存 In Stock    ○:非標準庫存(請確認交貨期) Non-standard Stock

刀片 Insert : ISCAR

# Zy 內徑端面切槽刀 Internal Face Grooving With Coolant

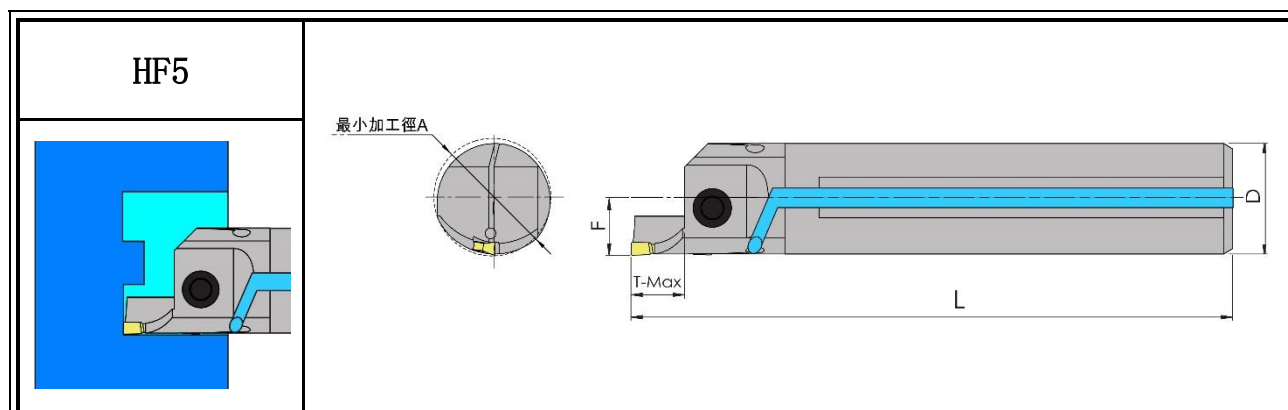



Stock	型號 Model No.	A 最小 A Max	A 最大 A Min	F	D	L	T-Max	螺絲 Screw	扳手 Wrench
●	ZTIFR-2529A25M-HF5-20	25	29	13.5	25	150	20	HTM5x16L	P4.0
●	ZTIFR-2530A25M-HF5-12	25	30		25	150	12		
●	ZTIFR-2831A25M-HF5-17	28	31		25	150	17		
●	ZTIFR-3135A25M-HF5-17	31	35		25	150	17		
●	ZTIFR-3540A25M-HF5-20	32	40		25	150	20		
●	ZTIFR-4045A25M-HF5-20	40	45		25	150	20		
●	ZTIFR-4555A25M-HF5-25	45	55		25	150	25		
○	ZTIFR-5570A32R-HF5-25	55	70	17	32	200	25	HTM5x16L	P4.0
○	ZTIFR-7095A32R-HF5-25	70	95		32	200			
○	ZTIFR-95130A32R-HF5-25	95	130		32	200			
○	ZTIFR-130180A32R-HF5-25	130	180		32	200			
○	ZTIFR-180800A32R-HF5-25	180	800		32	200			
○	ZTIFR-200800A32R-HF5-25	200	800		32	200			

●:庫存 In Stock    ○:非標準庫存(請確認交貨期) Non-standard Stock

刀片 Insert : ISCAR

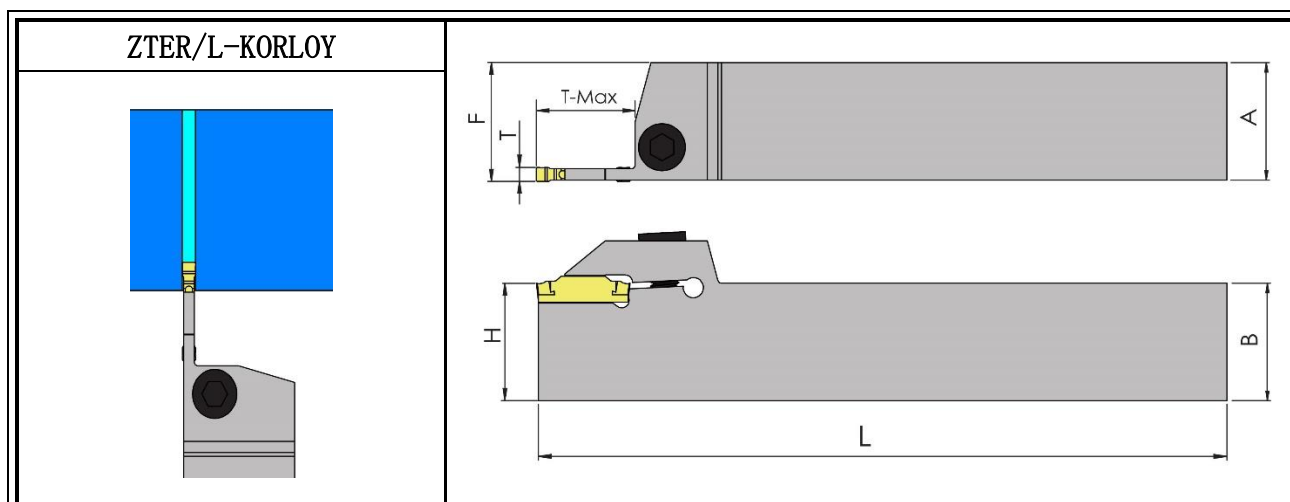
# Zy 外徑切槽刀 External Grooving



Stock		型號 Model No.	A	B=H	F	L	T	T-Max	 螺絲 Screw	 板手 Wrench
R	L									
●	●	ZTER/L-2020K-MG2-14	20	20	20	125	2	14	HTM6x20L	P5.0
●	●	ZTER/L-2020K-MG2-18	20	20	20	125		18	HTM6x20L	
●	●	ZTER/L-2525M-MG2-14	25	25	25	150	2	14	HTM6x25L	
●	●	ZTER/L-2525M-MG2-18	25	25	25	150		18	HTM6x25L	
●	●	ZTER/L-2020K-MG3-20	20	20	20	125	3	20	HTM6x20L	P5.0
●	○	ZTER/L-2525M-MG3-10	25	25	25	150		10	HTM6x25L	
●	●	ZTER/L-2525M-MG3-20	25	25	25	150		20	HTM6x25L	
●	●	ZTER/L-2020K-MG4-20	20	20	20	125	4	20	HTM6x20L	P5.0
●	●	ZTER/L-2525M-MG4-20	25	25	25	150		20	HTM6x25L	
○	○	ZTER/L-2020K-MG5-25	20	20	20	125	5	25	HTM6x20L	P5.0
●	●	ZTER/L-2525M-MG5-25	25	25	25	150		25	HTM6x25L	

●:庫存 In Stock    ○:非標準庫存(請確認交貨期) Non-standard Stock

刀片 Insert : KORLOY

MG2= MGN200

MG3= MGN300

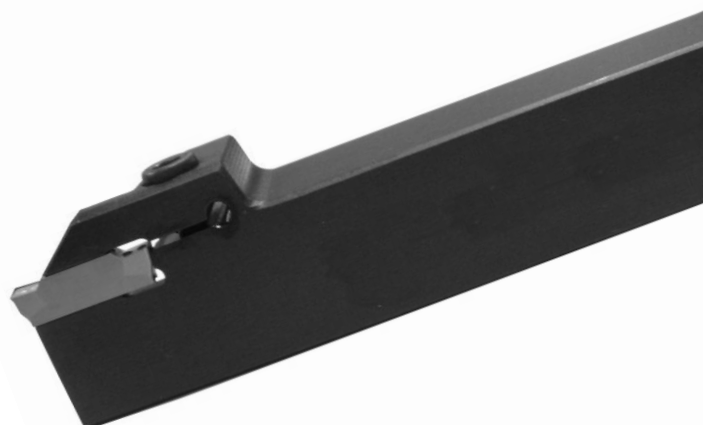

MG4= MGN400

MG5= MGN500

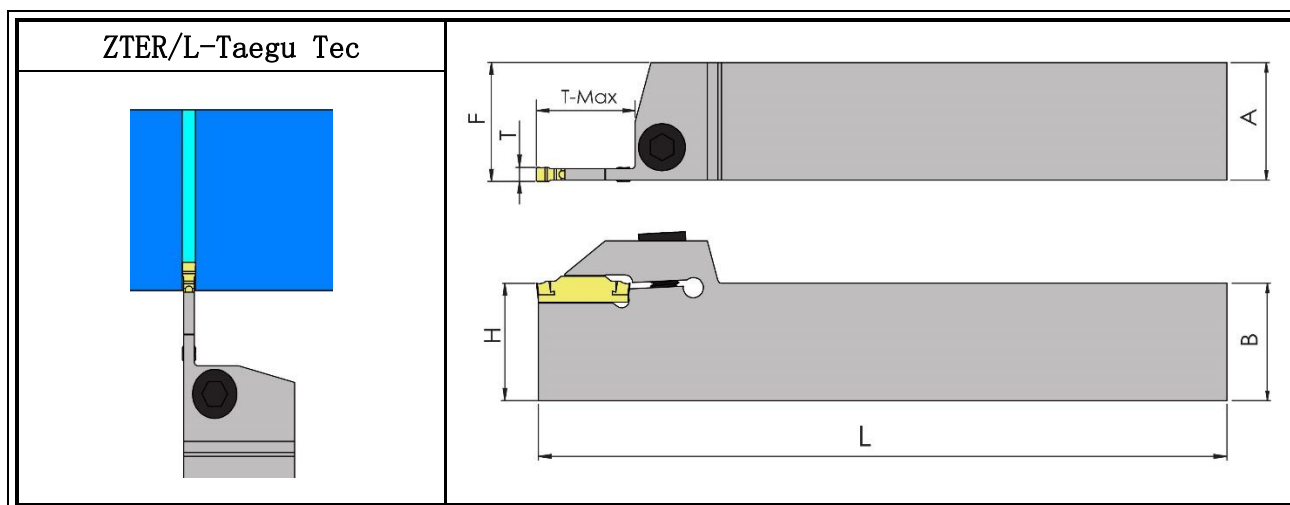

# Zy 外徑切槽刀 External Grooving



Stock		型號 Model No.	A	B=H	F	L	T	T-Max	 螺絲 Screw	 板手 Wrench
R	L									
●	●	ZTER/L-2020K-TD2-17	20	20.1	20	125	2	17	HTM6x20L	P5.0
●	○	ZTER/L-2525M-TD2-17	25	25.1	25	150	2	17	HTM6x25L	
●	○	ZTER/L-2020K-TD3-20	20	20.3	20	125	3	20	HTM6x20L	
●	○	ZTER/L-2525M-TD3-20	25	25.3	25	150	3	20	HTM6x25L	
●	○	ZTER/L-2525M-TD4-25	25	25.5	25	150	4	25	HTM6x16L	
●	○	ZTER/L-2525M-TD5-32	25	25.5	25	150	5	32	HTM6x25L	



●:庫存 In Stock    ○:非標準庫存(請確認交貨期) Non-standard Stock

刀片 Insert : Taegu Tec

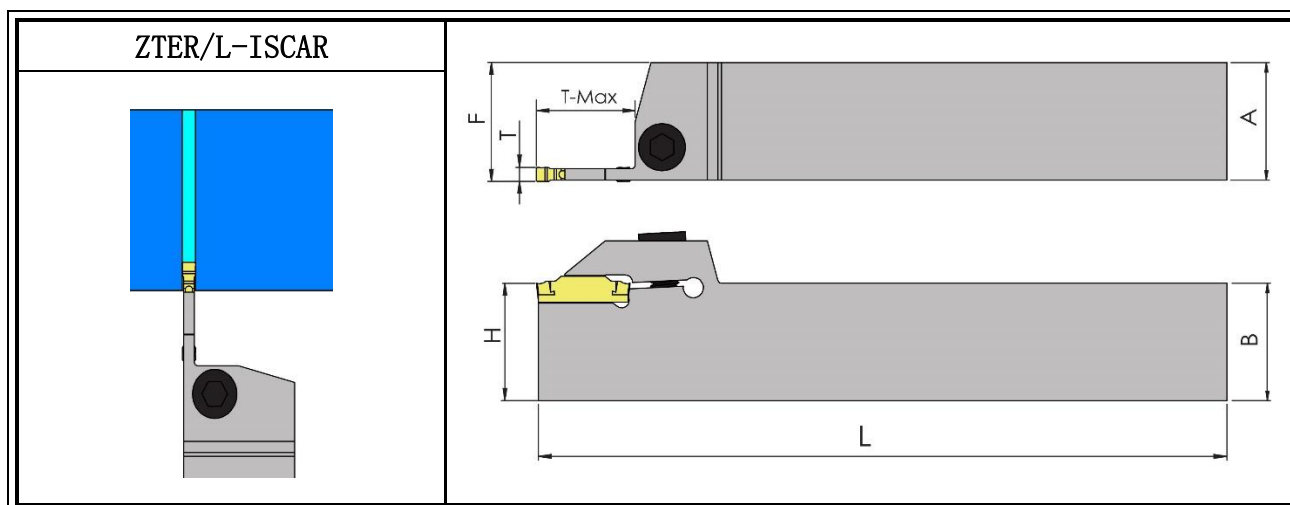

# Zy 外徑切槽刀 External Grooving



Stock		型號 Model No.	A	B=H	F	L	T	T-Max	 螺絲 Screw	 板手 Wrench
R	L									
●	●	ZTER/L-2020K-DGN2-17	20	20	20	125	2	17	HTM6x20L	P5.0
●	●	ZTER/L-2525M-DGN2-17	25	25	25	150	2	17	HTM6x25L	
●	●	ZTER/L-2020K-DGN3-20	20	20	20	125	3	20	HTM6x20L	
●	●	ZTER/L-2525M-DGN3-20	25	25	25	150	3	20	HTM6x25L	



●:庫存 In Stock    ○:非標準庫存(請確認交貨期) Non-standard Stock

刀片 Insert : ISCAR

# Zy 外徑切槽刀-自動車床用

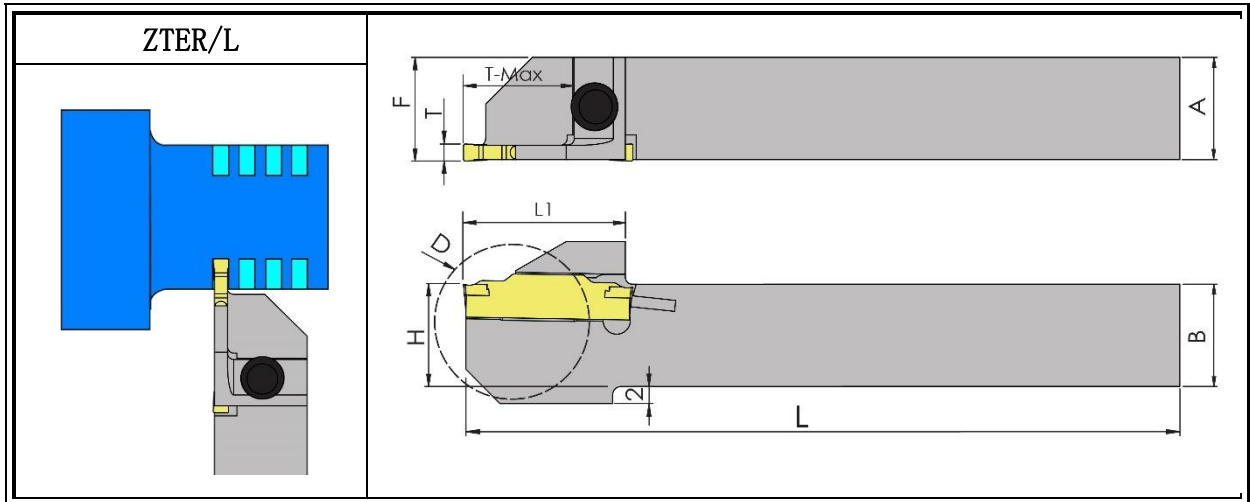

External Grooving  
For Automatic Lathes



Stock		型號 Model No.	D	A	B=H	L	L1	T	T-Max	 螺絲 Screw	 板手 Wrench
R	L										
●	●	ZTER/L-1010K-MGX20A-10	20	10	10	125	18	2	10.5	M4x12.0x5.6	T15
●	●	ZTER/L-1212K-MGX20A-12.5	25	12	12	125	19.5		13	M4x16.1x5.4	
●	●	ZTER/L-1616K-MGX20A-16	32	16	16	125	25		16.5		



●:庫存 In Stock ○:非標準庫存(請確認交貨期) Non-standard Stock

刀片 Insert : KORLOY

Stock		型號 Model No.	D	A	B=H	L	L1	T	T-Max	 螺絲 Screw	 板手 Wrench
R	L										
●	●	ZTER/L-1212K-TD2SH-24	24	12	12	125	19	2	12	M4x16.1x5.4	T15
●	●	ZTER/L-1616K-TD2SH-32	32	16	16	125	24		16	M4x20.0x5.4	

●:庫存 In Stock ○:非標準庫存(請確認交貨期) Non-standard Stock

刀片 Insert : Taegu Tec

Stock		型號 Model No.	D	A	B=H	L	L1	T	T-Max	 螺絲 Screw	 板手 Wrench
R	L										
●	●	ZTER/L-1212K-DGN2-12.5	12.5	12	12	125	19.5	2	12	M4x16.1x5.4	T15
●	●	ZTER/L-1616K-DGN2-16	16	16	16	125	25		16	M4x20.0x5.4	

●:庫存 In Stock ○:非標準庫存(請確認交貨期) Non-standard Stock

刀片 Insert : ISCAR

# Zy 外徑端面切槽刀架 External Face Grooving

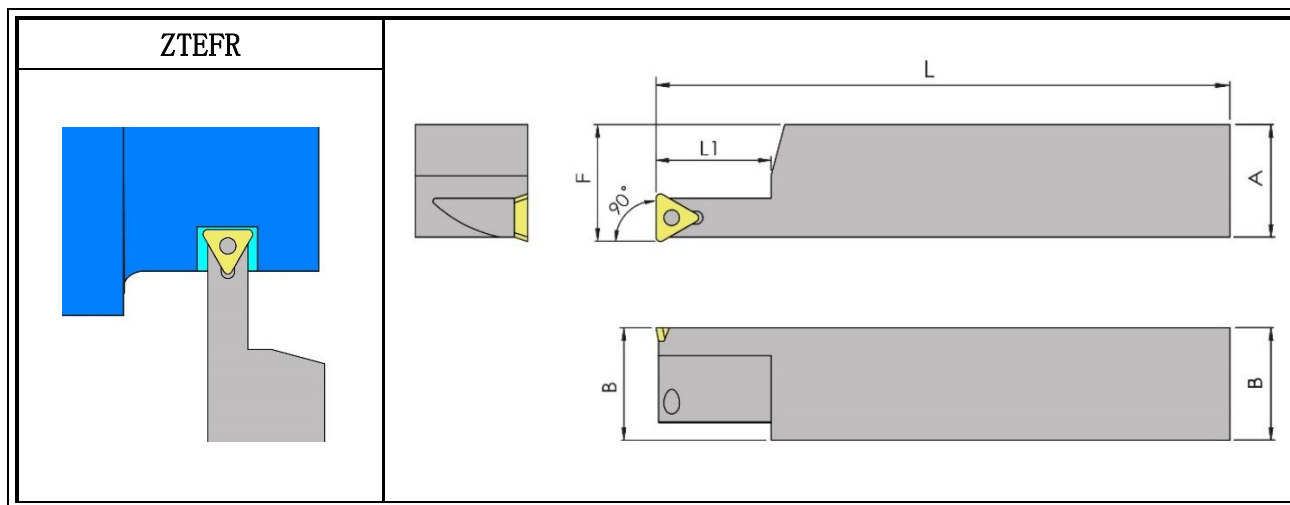



Stock	型號 Model No.	A	B	F	L	L1	螺絲 Screw	扳手 Wrench	刀片 Insert
●	ZTEFR-50/100 2525M-TP09-20	25	25	25.8	150	20	M2.5x6.0x3.6	T15	TP0902
●	ZTEFR-50/100 2525M-TP11-20	25	25	25	150	20	M3x7.8x4.1	T9	TP1103

●:庫存 In Stock    ○:非標準庫存(請確認交貨期) Non-standard Stock

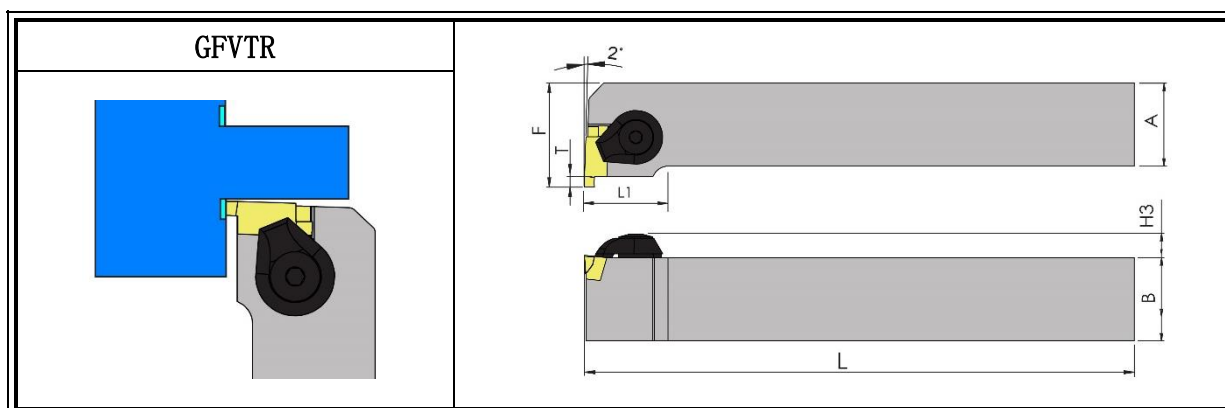
# Zy 外徑端面切槽刀架 External Face Grooving



Stock	型號 Model No.	A	B	F	L	L1	T	H3	 螺絲 Screw	 板手 Wrench	刀片 Insert
●	GFVTR-1212K-08AA	12	12	16	125	16	2.2	5.5	GCPA-0513 GCPC0514-51	T20	GVFL100AA GVFL300AA
●	GFVTR-1616K-08AA	16	16	20	125						
●	GFVTR-2020K-08AA	20	20	25	125						
●	GFVTR-2525M-08AA	25	25	32	150						



●:庫存 In Stock    ○:非標準庫存(請確認交貨期) Non-standard Stock

刀片 Insert : Kyocera (京瓷)

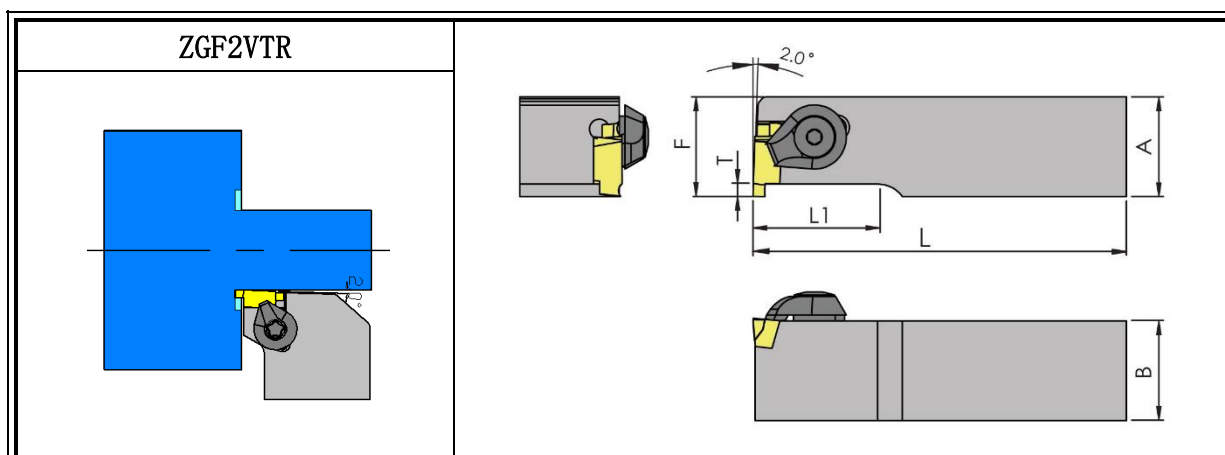

# Zy 走心式外徑端面切槽刀架 External Face Grooving For Automatic Lathes



Stock	型號 Model No.	A	B	F	L	L1	T	 螺絲 Screw	 板手 Wrench	刀片 Insert
●	ZGF2VTR-1010K-08AA	10	10	10	125	20	2.2	GCPA-0513 GCPC0514-51	T20	GVFL100AA GVFL300AA
●	ZGF2VTR-1212K-08AA	12	12	12	125					
●	ZGF2VTR-1616K-08AA	16	16	16	125					

●:庫存 In Stock    ○:非標準庫存(請確認交貨期) Non-standard Stock

刀片 Insert : Kyocera (京瓷)

# Zy 模組化內徑切槽刀頭 Modular Internal Grooving Head With Coolant

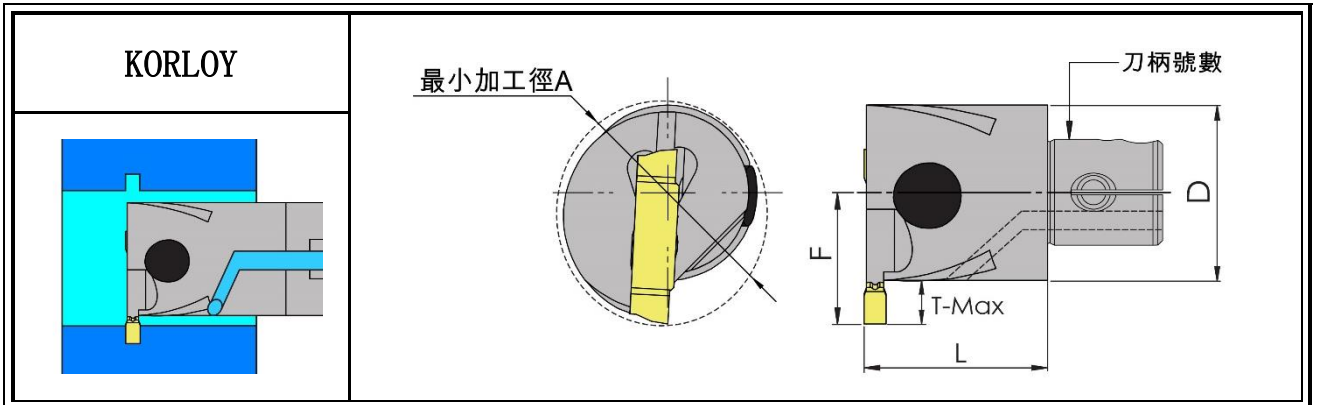

Stock	型號 Model No.	最小加工徑 A	F	D	L	T-Max	S	螺絲 Screw	板手 Wrench
●	SCK1-A2720-MG2-6	27	14	20	24	4.5	24	M5	P4.0
●	SCK1-A2720-MG3-6	27	15.6	20	24	5	25.6		
●	SCK1-A2720-MG4-6	27	15.6	20	24	6	25.6		
●	SCK2-A3225-MG4-6	32	18.9	25	25	6	31.4		
●	SCK2-A3225-MG2-6	32	17.2	25	25	4.5	29.7		
●	SCK2-A3225-MG3-6	32	18.9	25	25	6	31.4		

●:庫存 In Stock    ○:非標準庫存(請確認交貨期) Non-standard Stock

刀片 Insert : KORLOY

MG2 = MGMN200

MG3 = MGMN300

MG4 = MGMN400

MG5 = MGMN500

# Zy 模組化內徑切槽刀頭 Modular Internal Grooving Head With Coolant

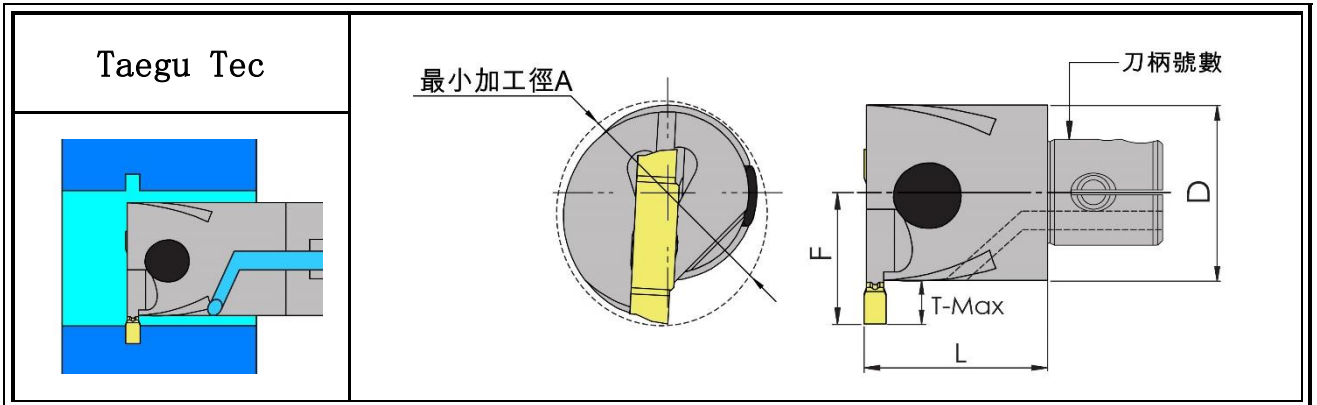

Stock	型號 Model No.	最小加工徑 A	F	D	L	T	S	螺絲 Screw	板手 Wrench
○	SCK1-A2720-TD2-6	27	15.8	20	24	6	25.8	M5	P4.0
○	SCK1-A2720-TD3-6	27	15.8	20	24	6	25.8		
○	SCK2-A3225-TD2-6	32	17.5	25	25	5	30		
○	SCK2-A3225-TD3-6	32	17.5	25	25	5.1	30		

●:庫存 In Stock    ○:非標準庫存(請確認交貨期) Non-standard Stock

刀片 Insert : Taegu Tec

# Zy 模組化內徑端面切槽刀頭 Modular Internal Face Grooving Head With Coolant

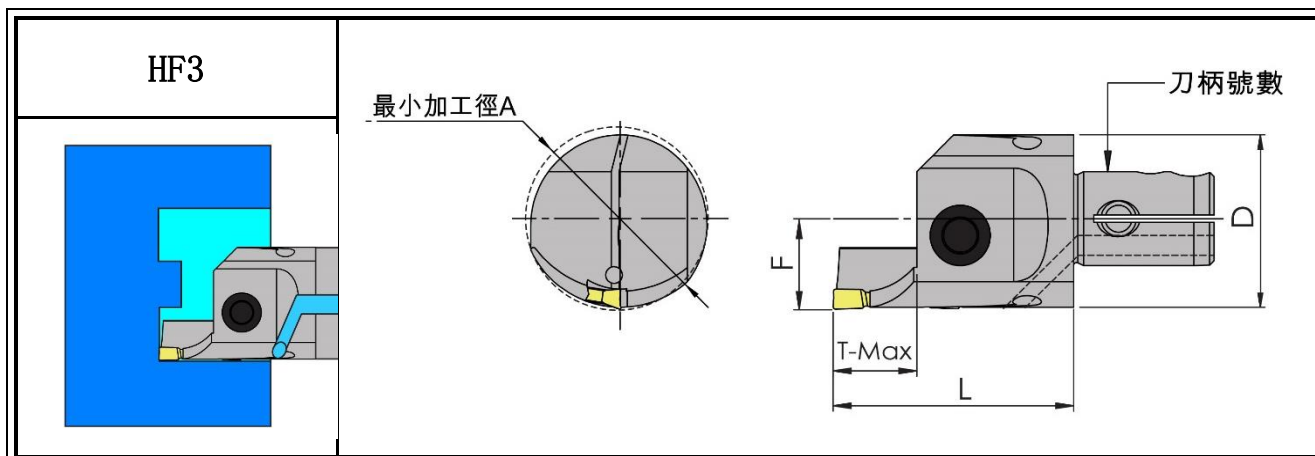

Stock	型號 Model No.	A 最小 A Max	A 最大 A Min	F	D	L	T-Max	螺絲 Screw	板手 Wrench
●	ZTIFR-2530SCK2-HF3-12L	25	30	13.5	25	150	12	HTM5x16L	L4.0
●	ZTIFR-3038SCK2-HF3-12L	30	38		25	150			
●	ZTIFR-3848SCK2-HF3-12L	38	48		25	150	22		
●	ZTIFR-4860SCK2-HF3-22L	48	60		25	150			
●	ZTIFR-6075SCK2-HF3-22L	60	75		25	150			
●	ZTIFR-75100SCK2-HF3-25L	75	100		25	150	25		

●:庫存 In Stock    ○:非標準庫存(請確認交貨期) Non-standard Stock

刀片 Insert : ISCAR



# Zy 模組化內徑端面切槽刀頭 Modular Internal Face Grooving Head With Coolant

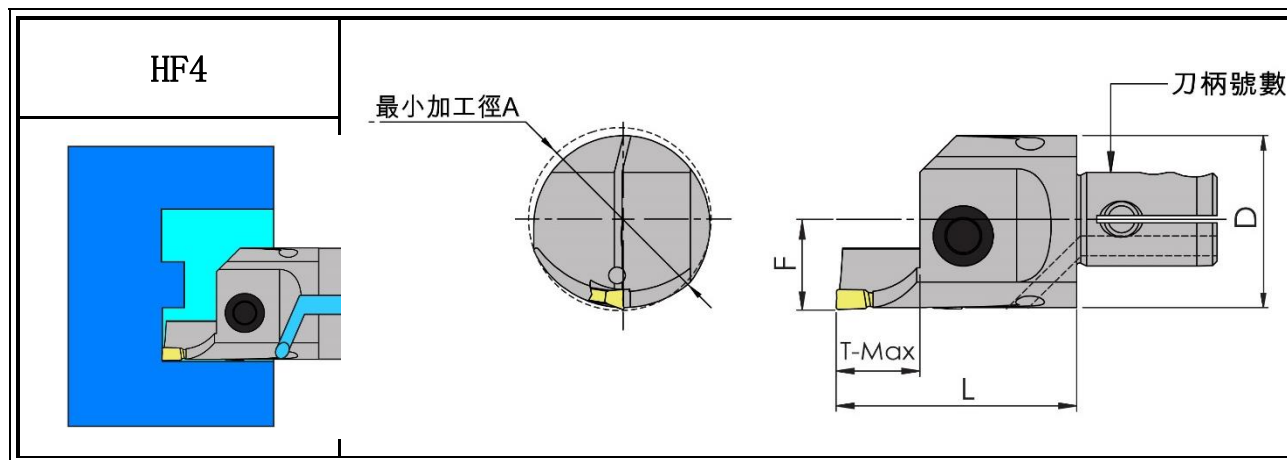

Stock	型號 Model No.	A 最小 A Max	A 最大 A Min	F	D	L	T-Max	螺絲 Screw	板手 Wrench
●	ZTIFR-2529SCK2-HF4-12L	25	29	13.5	25	150	12	HTM5x16L	P4.0
●	ZTIFR-2934SCK2-HF4-12L	29	34		25	150			
●	ZTIFR-3440SCK2-HF4-20L	34	40		25	150	20		
●	ZTIFR-4048SCK2-HF4-25L	40	48		25	150	25		
●	ZTIFR-4860SCK2-HF4-25L	48	60		25	150			
●	ZTIFR-6075SCK2-HF4-25L	60	75		25	150			
●	ZTIFR-75100SCK2-HF4-25L	75	100	25	200				
●	ZTIFR-100140SCK3-HF4-25L	100	140	17	32	200	25	HTM5x16L	P4.0
●	ZTIFR-140240SCK3-HF4-25L	140	240		32	200			
●	ZTIFR-240800SCK3-HF4-25L	240	800		32	200			

●:庫存 In Stock    ○:非標準庫存(請確認交貨期) Non-standard Stock

刀片 Insert : ISCAR

# Zy 模組化內徑端面切槽刀頭 Modular Internal Face Grooving Head With Coolant

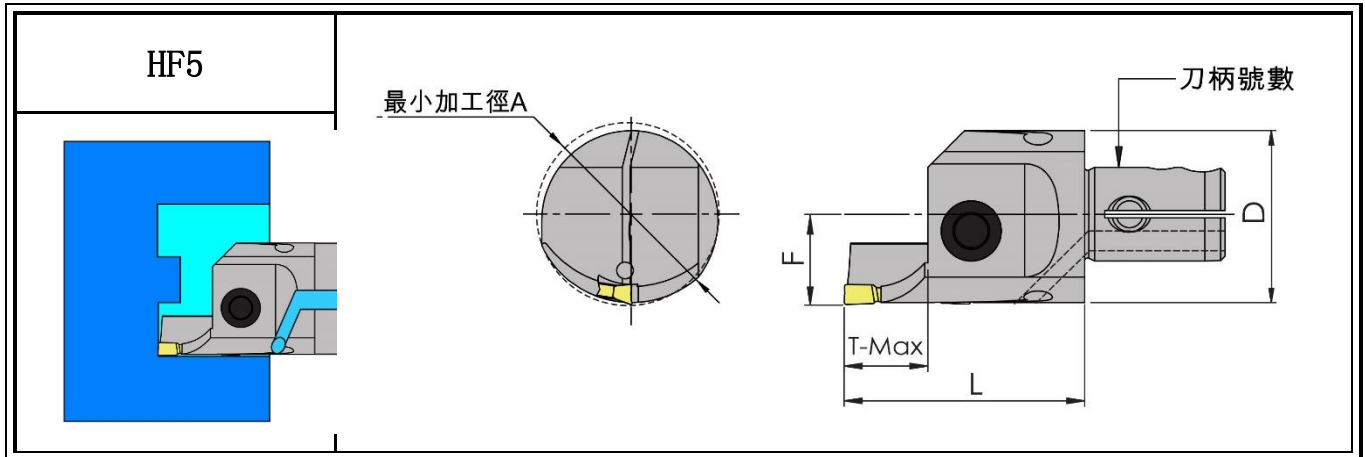

Stock	型號 Model No.	A 最小 A Max	A 最大 A Min	F	D	L	T-Max	螺絲 Screw	板手 Wrench
●	ZTIFR-2529SCK2-HF5-20L	25	29	13.5	25	150	20	HTM5x16L	P4.0
●	ZTIFR-2530SCK2-HF5-12L	25	30		25	150	12		
●	ZTIFR-2831SCK2-HF5-17L	28	31		25	150	17		
●	ZTIFR-3135SCK2-HF5-17L	31	35		25	150	17		
●	ZTIFR-3540SCK2-HF5-20L	32	40		25	150	20		
●	ZTIFR-4045SCK2-HF5-20L	40	45		25	150	20		
●	ZTIFR-4555SCK2-HF5-25L	45	55		25	150	25		
●	ZTIFR-5570SCK3-HF5-25L	55	70	17	32	200	25	HTM5x16L	P4.0
●	ZTIFR-7095SCK3-HF5-25L	70	95		32	200			
●	ZTIFR-95130SCK3-HF5-25L	95	130		32	200			
●	ZTIFR-130180SCK3-HF5-25L	130	180		32	200			
●	ZTIFR-180800SCK3-HF5-25L	180	800		32	200			
●	ZTIFR-200800SCK3-HF5-25L	200	800		32	200			

●:庫存 In Stock    ○:非標準庫存(請確認交貨期) Non-standard Stock

刀片 Insert : ISCAR



# 牙刀系列



- 碳化鎢鋼牙刀
- 合金鋼牙刀
- 外徑牙刀
- 模組化刀頭牙刀

# Zy 內徑牙刀 Internal Threading Boring Bars

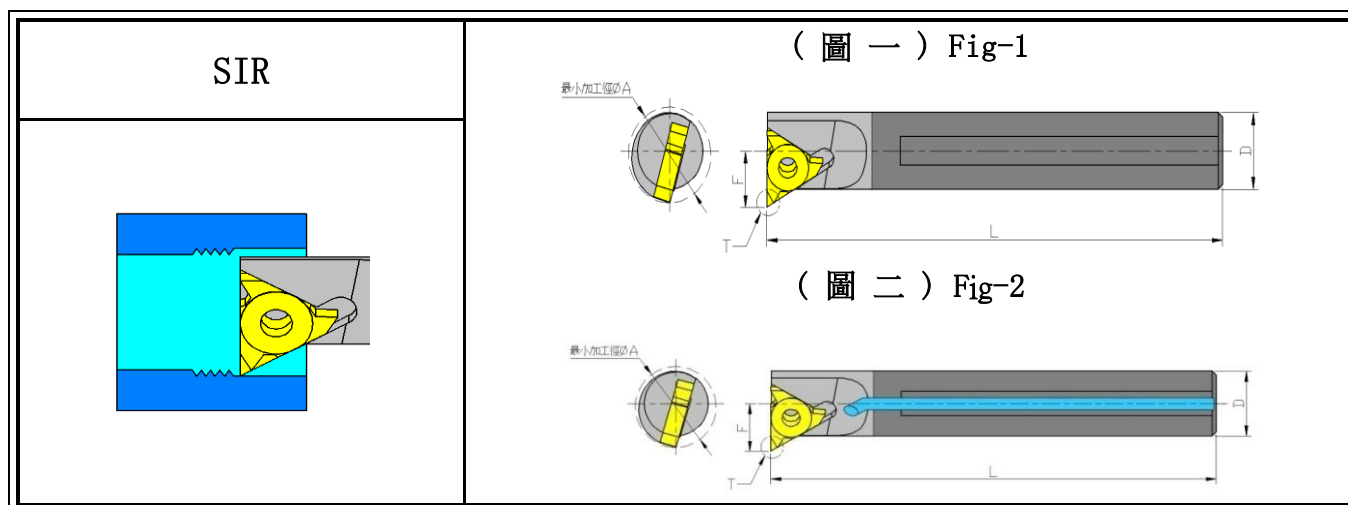

Stock	型號 Model No.	最小加工徑	F	D	L	墊片 Shim	墊片 Shim	螺絲 Screw	板手 Wrench	刀片 Insert
鎢鋼柄 (圖一) Carbide Shank (Fig-1)										
●	SIR/L0005H-06C-064	6.4	3.98	5	100	-	-	M2x5.0x2.6	T6	06NR/L
●	SIR/L0006J-06C-076	7.6	4.48	6	110	-	-			
●	SIR/L0006J-08C-09	9	5	6	110	-	-	M2.2x5.1x3.1	T7	08NR/L
●	SIR/L0008K-08C-10	10	5.9	8	125	-	-			
●	SIR/L0010M-11C-12	12	7.4	10	150	-	-	M2.5x6.0x3.6	T8	11NR/L
●	SIR/L0012M-11C-15	15	8.5	12	150	-	-			
●	SIR/L0014M-16C-18	18	10.6	14	150	-	-	M3.5x7.6x5.1-60	T15	16NR/L
●	SIR/L0016M-16C-19	19	11.7	16	150	-	-			
●	SIR/L0016R-16C-19	19	11.7	16	200	-	-			
●	SIR/L0020R-16C-24	24	13.7	20	200	-	-			
●	SIR/L0020S-16C-24	24	13.7	20	250	-	-			
●	SIR/L0025R-16C-29	29	16.2	25	200	GXN16	HTM305	M3.5x11.4x5.1		
○	SIR/L0032R-16C-36	36	18.8	32	200	GXN16	HTM305	M3.5x11.4x5.1		
○	SIR/L0032R-22C-40	40	20.95	32	200	SNR22	HTM306	M4x15.9x7.0	T15	22NR/L
合金鋼柄 (圖一) Alloy Steel (Fig-1)										
●	SINR1008-08	10	5.91	8	125	-	-	M2.2x5.1x3.1	T7	08NR/L
●	SINR1210-11	12	7.4	10	125	-	-	M2.5x6.0x3.6	T8	11NR/L
●	SINR1512-11	15	8.5	12	150	-	-			
●	SINR2016-16	20	11.7	16	180	-	-	M3.5x7.6x5.1-60	T15	16NR/L

●	SINR2420-16	24	13.7	20	200					
●	SINR2925-16	29	16.2	25	200	GXN16	HTM305	M3.5x11.4x5.1		
鎢鋼柄 + 水孔 (圖二) Carbide Shank With Coolant (Fig-2)										
●	SIR/L0005H-06E-064	6.4	4.3	5	100	-	-	M2x5.0x2.6	T6	06NR/L
●	SIR/L0006J-06E-076	7.6	4.48	6	110					
●	SIR/L0008K-08E-10	10	5.9	8	125			M2.2x5.1x3.1	T7	08NR/L
●	SIR/L0010M-11E-12	12	7.4	10	150					
●	SIR/L0012M-11E-15	15	8.5	12	150			M2.5x6.0x3.6	T8	11NR/L
●	SIR/L0016R-16E-19	19	11.7	16	200					
高硬度柄 (Y:圖二、Z:圖一) High Hardness Steel With Coolant (Y:Fig-2、Z:Fig-1)										
○	SIR0010K-11Y-12	12	7.4	10	125	-	-	M2.5x6.0x3.6	T8	11NR/L
●	SIR0010K-11Z-12	12	7.4	10	125					
●	SIR0012M-11Y-15	15	8.5	12	150					
●	SIR0012M-11Z-15	15	8.5	12	150					
●	SIR0016N-16Y-19	19	11.7	16	160			M3.5x7.6x5.1-60	T15	16NR/L
○	SIR0016N-16Z-19	19			150					
○	SIR0016Q-16Y-19	19			180					
●	SIR0016Q-16Z-19	19			180					
●	SIR0020R-16Y-24	24	13.7	20	200					
●	SIR0020R-16Z-24	24	13.7	20	200					

●:庫存 In Stock    ○:非標準庫存(請確認交貨期) Non-standard Stock

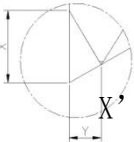
 <p>T 部詳圖 X' Y' 尺寸參考刀片 Insert 規格</p>					
型號 Model No.	最小螺紋	型號 Model No.	最小螺紋	型號 Model No.	最小螺紋
SIR0005H-06C-064	M8	SIR0012M-11C-15	M18	SIR0025S-16C-29	M33
SIR0008K-08C-10	M11	SIR0016M-16C-19(S)	M22		
SIR0010M-11C-12	M14	SIR0020R-16C-24(S)	M27		

# Zy 縮小徑內徑牙刀 Internal Threading Boring Bars

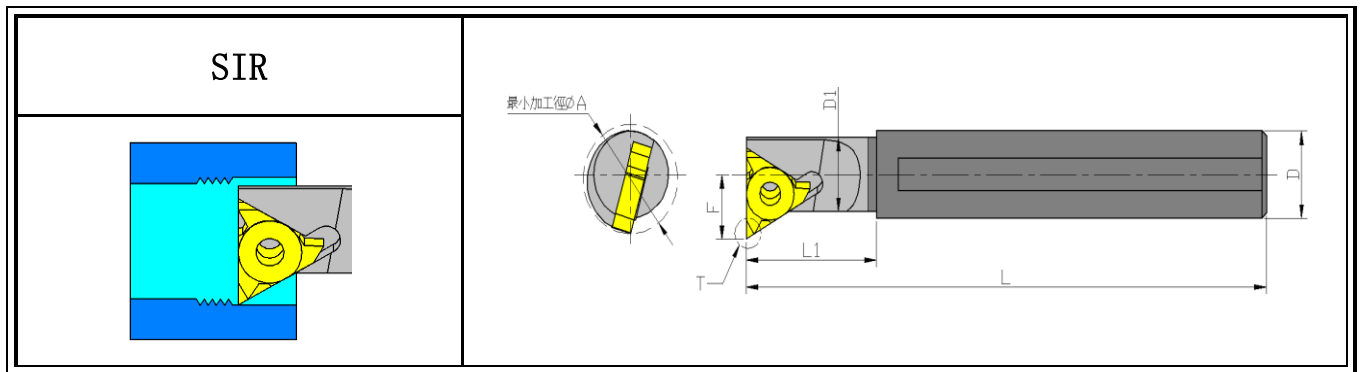

Stock	型號 Model No.	最小加工徑 A	F	D	D1	L	L1	螺絲 Screw	扳手 Wrench	刀片 Insert
鎢鋼柄 (圖一) Carbide Shank (Fig-1)										
●	SIR0008K-08C-09-20L	9	5	8	6.1	125	20	M2.2x5.1x3.1	T7	08IR/L
●	SIR0008K-08C-10-20L	10	5.5	8	7.4	125	20			
合金鋼柄 (圖一) Alloy Steel (Fig-1)										
●	SINR0612-06-10L	6.4	4.3	12	5.1	125	10	M2x3.7x2.6-60	T6	06IR/L
●	SINR0816-08-18L	8	5	16	8	125	18	M2.2x5.1x3.1	T7	08IR/L
●	SINR1012-11-25L	10	5.8	12	8.3	150	25	M2.5x6.0x3.6	T8	11IR/L
●	SINR1216-11-25L	12	7.4	16	10	150	25			
●	SINR1516-11-30L	15	8.5	16	12	150	30			
高硬度柄 (Y:圖二、Z:圖一) High Hardness Steel With Coolant (Y:Fig-2、Z:Fig-1)										
●	SIR001206K-06Y-076-20L	7.6	4.48	12	6	125	20	M2x3.7x2.6-60	T6	06IR/L
●	SIR001206K-06Z-076-20L	7.6	4.48	12	6	125	20			
●	SIR001208H-11Z-10-25L	10	5.8	12	8.3	100	25	M2.5x6.0x3.6	T8	11IR/L

●:庫存 In Stock    ○:非標準庫存(請確認交貨期) Non-standard Stock

T 部詳圖

X' Y' 尺寸參考刀片 Insert 規格

型號 Model No.	最小螺紋
SIR0008K-08C-09-20L	M10
SIR0008K-08C-10-20L	M11

# Zy 外徑牙刀 External Threading Turning Tools

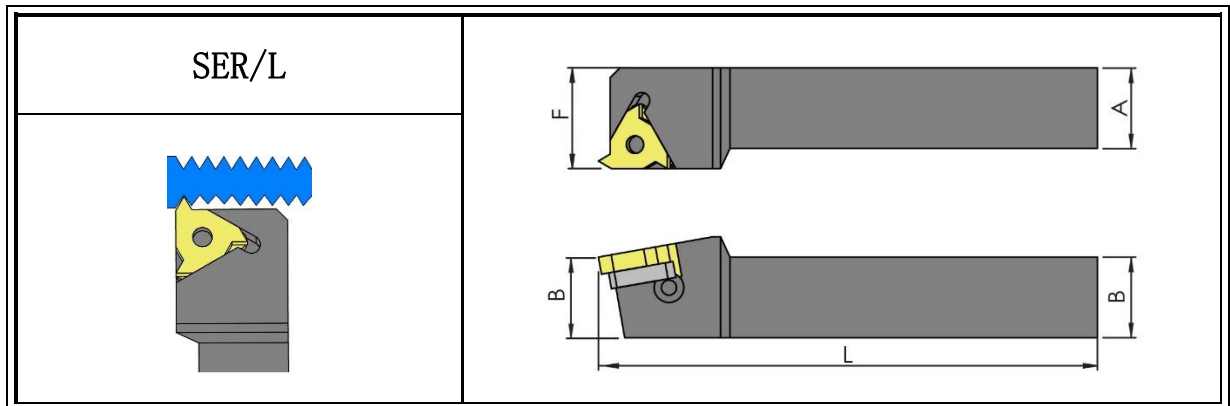



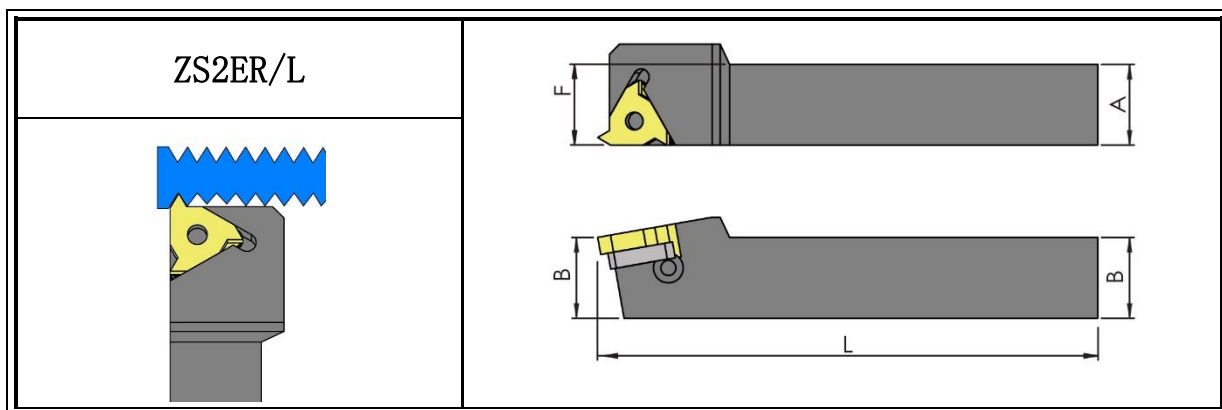

Stock	型號 Model No.	A	B	F	L	螺絲 Screw	墊片 Shim	螺絲 Shim Screw	板手 Wrench
●	SER-1616K-16	16	16	20	125	M3.5x11.4x5.1	GXE16 GXN16	M3	T15 L:2.5
●	SER-2020K-16	20	20	25	125				
●	SER-2525M-16	25	25	32	150				
●	SEL-1616K-16	16	16	20	125				
●	SEL-2020K-16	20	20	25	125				
●	SEL-2525M-16	25	25	32	150				

●:庫存 In Stock    ○:非標準庫存(請確認交貨期) Non-standard Stock

# Zy 外徑走心式牙刀 External Threading With Coolant For Automatic Lathes



Stock	型號 Model No.	A	B	F	L	 螺絲 Screw	 墊片 Shim	 螺絲 Shim Screw	 板手 Wrench
●	ZS2ER-1212K-16	12	12	12	125	M3.5x11.4x5.1	-	-	T15
●	ZS2ER-1616K-16	16	16	16	125		GXE16 GXN16	M3	T15 L:2.5

●:庫存 In Stock    ○:非標準庫存(請確認交貨期) Non-standard Stock





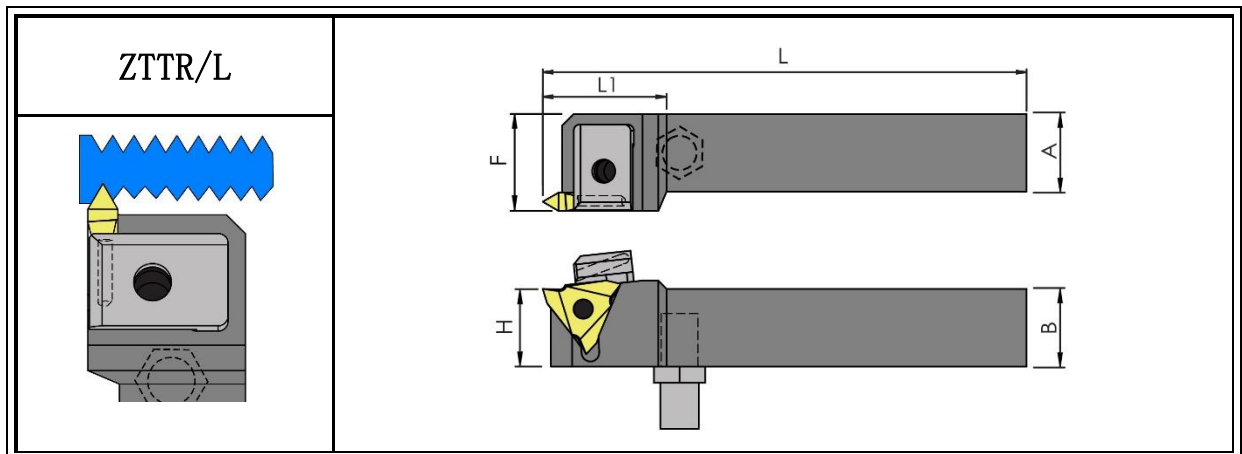



# Zy 外徑牙刀 External Threading Turning Tools

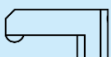

Stock	型號 Model No.	A	B	F	L	刀片 Insert
●	ZTTR/L-2020K-22	20	20	25	125	三菱
●	ZTTR/L-2525M-22	25	25	32	150	MTTR436002

●:庫存 In Stock    ○:非標準庫存(請確認交貨期) Non-standard Stock

## 配件 Tool Parts :

 壓板 Clamp	 螺絲 Screw	 壓板螺絲 Clamp Screw	 螺絲 Clamp Screw	 彈簧 Spring	 板手 Wrench
ZMTK1R/L	M5x13L	M5x25L	DS625	SP5309	L3.0

# Zy 模組化內徑牙刀頭 Modular Internal Threading Head With Coolant

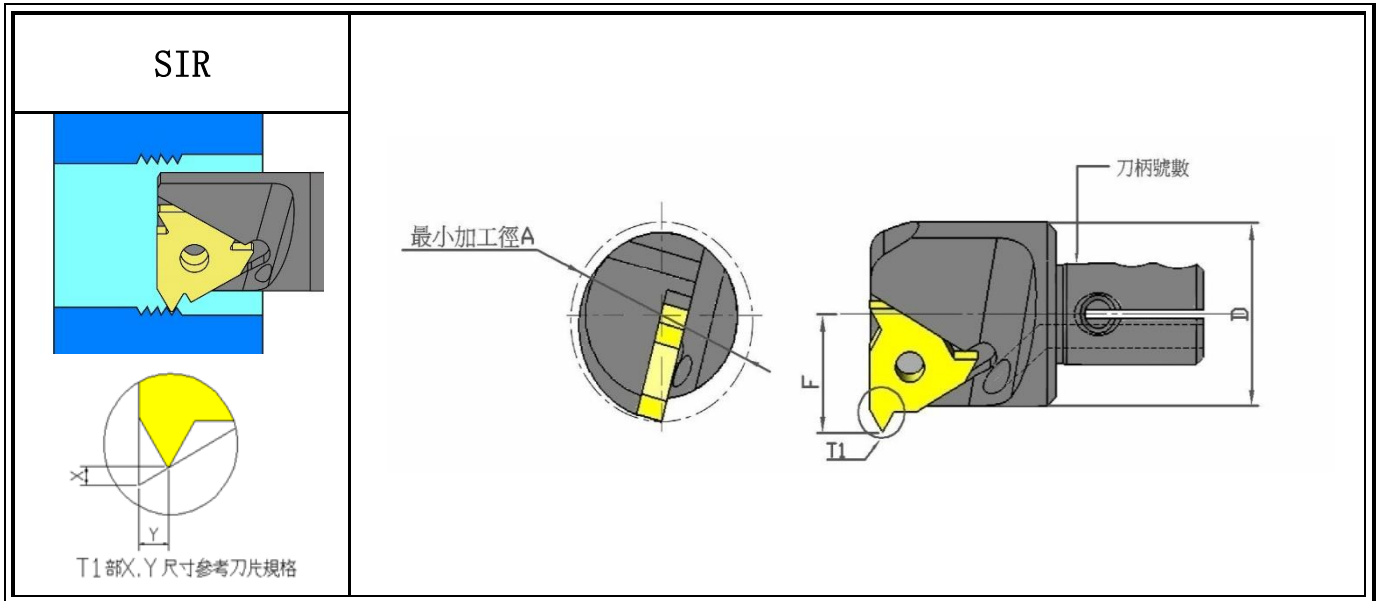

Stock	型號 Model No.	最小加工徑 A	F	D	L	 墊片 Shim	 墊片螺絲 Shim Screw	 螺絲 Screw	 板手 Wrench	刀片 Insert
●	SCK1-A20-SIR16-24	24	13.7	20	22	-	-	M3.5x7.6x5.1x60	T15	16NR/L
●	SCK2-A25-SIR16-29	29	16.2	25	27	STM16R	M3	M3.5x12.0x5.4x6		
●	SCK3-A32-SIR16-36	36	19.7	32	32	STM16R	M3	7		
●	SCK1-A20-SIR22-25	25	13.5	20	22	-	-	M4x11.1x6.8	T15	22NR/L
●	SCK2-A25-SIR22-32	32	18.1	25	27	-	-			
○	SCK3-A32-SIR22-40	40	20.95	32	32	STM22R	M4			

# 模組化系統

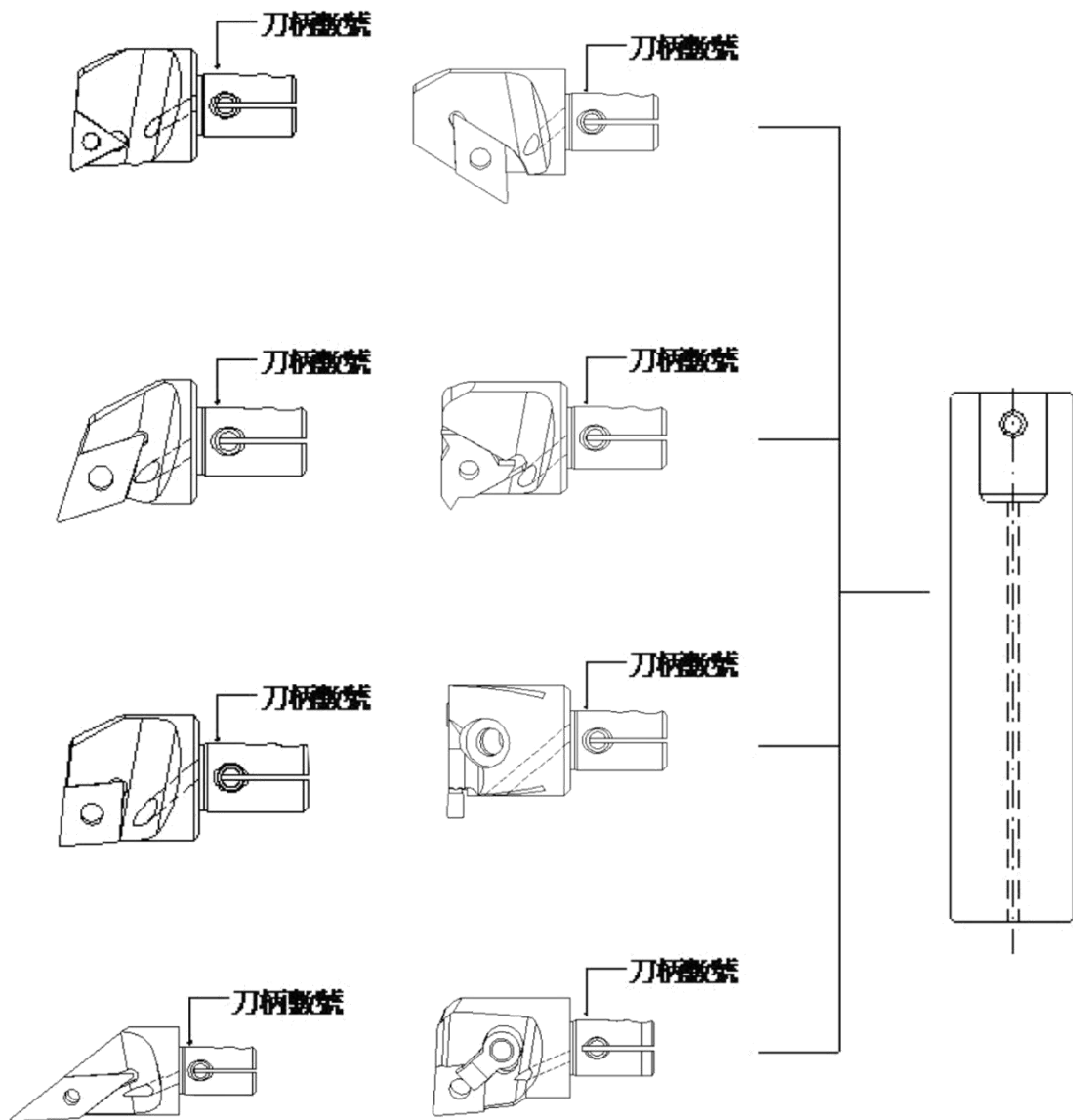

## 模組刀桿的使用價值

※ 價值一. 高鋼性,刀桿穩定,可延長刀片壽命 ※



超合金高硬度處理, 產生高鋼性刀桿.



※ 價值二. 多樣選擇, 減少重複購買 ※

一顆刀頭  
可裝在不同材質,長度的刀桿上

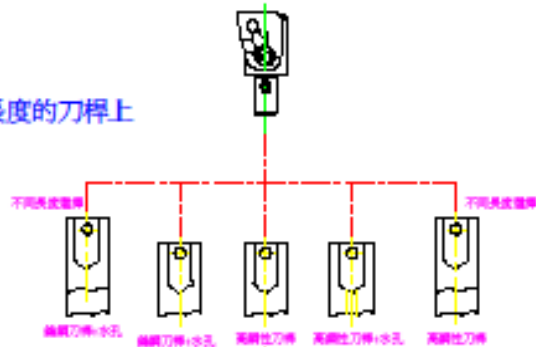

一支刀桿  
可裝上不同功能性的刀頭

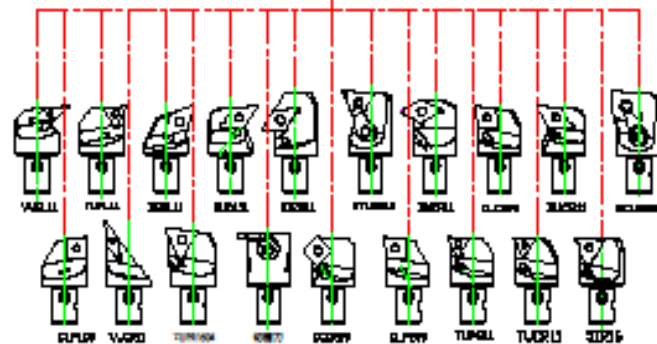

※ 價值三. 讓刀尖高度更準確, 加工更穩定 ※

V槽與鋼珠的定  
位結構,讓刀尖高  
度準確

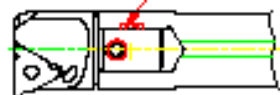

※ 價值四. 便宜 ※

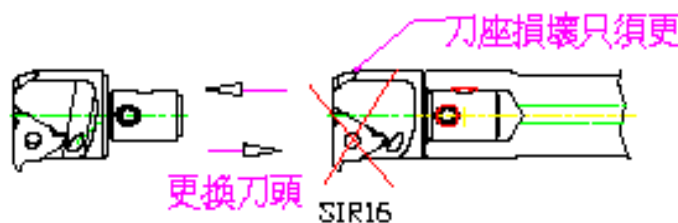

# 模組化刀桿及刀頭裝配步驟

軸向徑向貼合緊密

模組機構刀頭

裝配步驟 一.

鎖緊上下的固定螺絲。

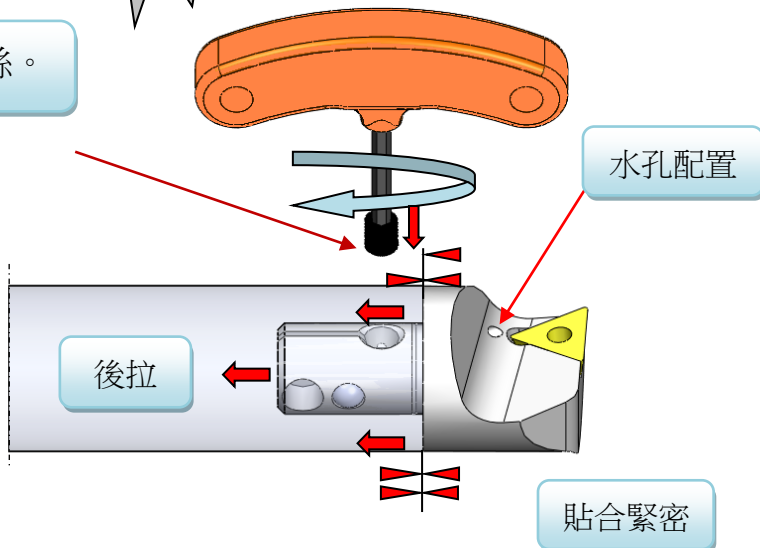

裝配步驟 二.

鎖緊第三孔頂開螺絲。

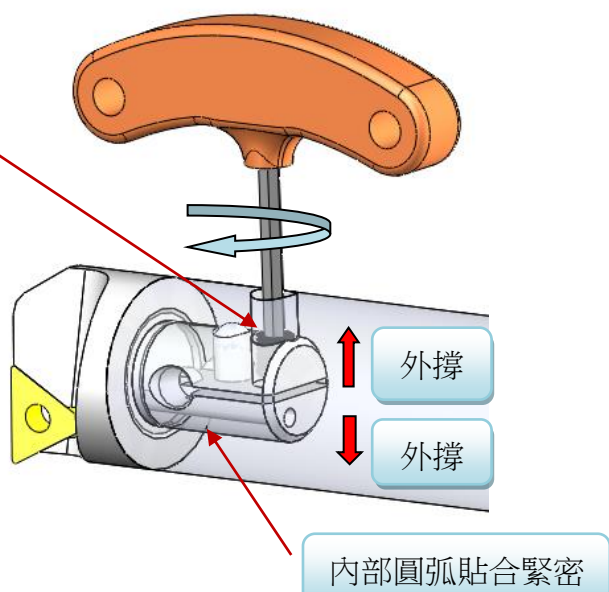

裝配步驟 三.

鎖緊第三孔止水螺絲。

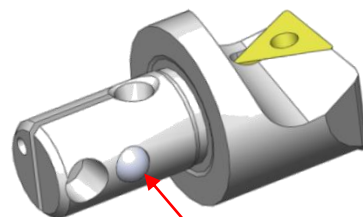
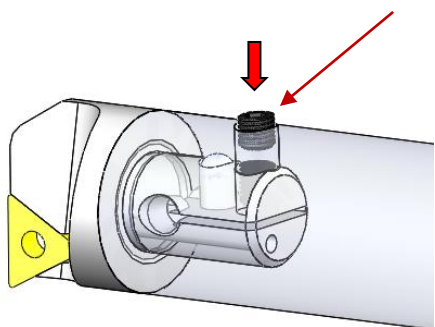

注意安全

注意拆卸時，步驟相反。

模組化刀頭拆裝時，需帶手套，避免刀片割傷手。

# SCK系列刀桿表示方法

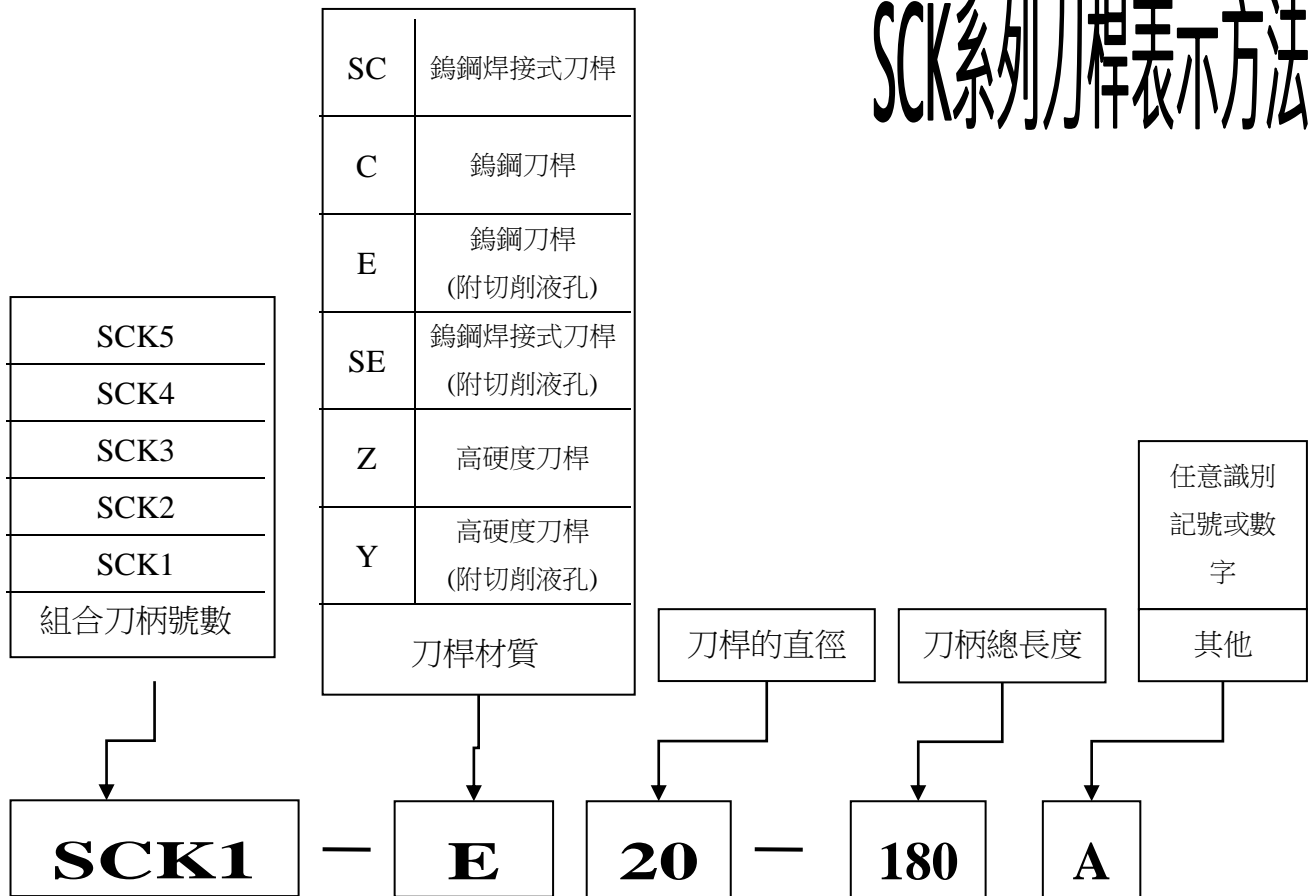

模組化 更換刀頭簡易，重複定位精準

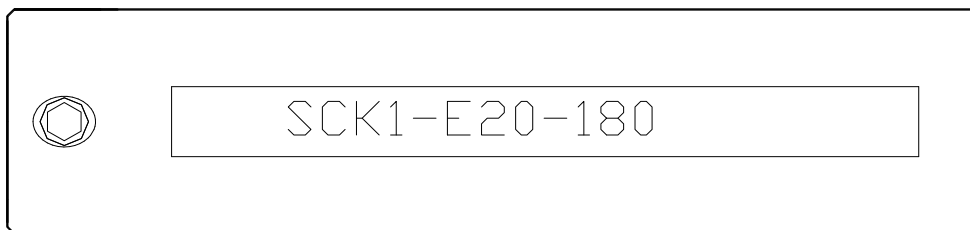

# Zy 模組化高硬度高剛性刀桿 Modular Chang High-Hardness Steel Boring Bars

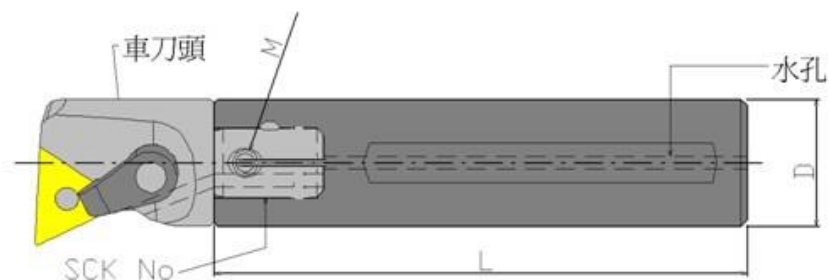

Stock	型號 Model No.	組合刀柄 SCK NO	D	L	螺絲 Screw	扳手 Wrench
●	SCK1-Y20-180L	SCK1	20	180	SETM5x8L	P2.5
●	SCK2-Y25-175L	SCK2	25	175	SETM6x8L	P3.0
●	SCK2-Y25-225L		25	225	SETM6x8L	P3.0
●	SCK3-Y32-170L	SCK3	32	170	SETM6x10L	P3.0
●	SCK3-Y32-220L		32	220	SETM6x10L	P3.0
●	SCK3-Y32-270L		32	270	SETM6x10L	P3.0
●	SCK4-Y40-267L	SCK4	40	267	SETM8x16L	P4.0
●	SCK5-Y50-290L	SCK5	50	290	SETM10x16L	P5.0
●	SCK1-Z20-180L	SCK1	20	180	SETM5x8L	P2.5
●	SCK2-Z25-175L	SCK2	25	175	SETM6x8L	P3.0

# Zy 模組化鎢鋼刀桿 Modular Chang Carbide Steel Boring Bars

Stock	型號 Model No.	組合刀柄 SCK NO	D	L	螺絲 Screw	扳手 Wrench
●	SCK1-E20-180L	SCK1	20	180	SETM5x8L	P2.5
●	SCK1-E20-230L		20	230	SETM5x8L	P2.5
●	SCK2-E25-175L	SCK2	25	175	SETM6x8L	P3.0
●	SCK2-E25-225L		25	225	SETM6x8L	P3.0
●	SCK3-E32-170L	SCK3	32	170	SETM6x10L	P3.0
●	SCK3-E32-220L		32	220	SETM6x10L	P3.0
●	SCK3-E32-270L		32	270	SETM6x10L	P3.0
○	SCK4-E40-267L	SCK4	40	267	SETM8x16L	P4.0
○	SCK5-E50-300L	SCK5	50	300	SETM10x16L	P5.0

●: 庫存 ○: 非標準庫存 (請確認交貨期)

# SCK系列車刀頭表示方法

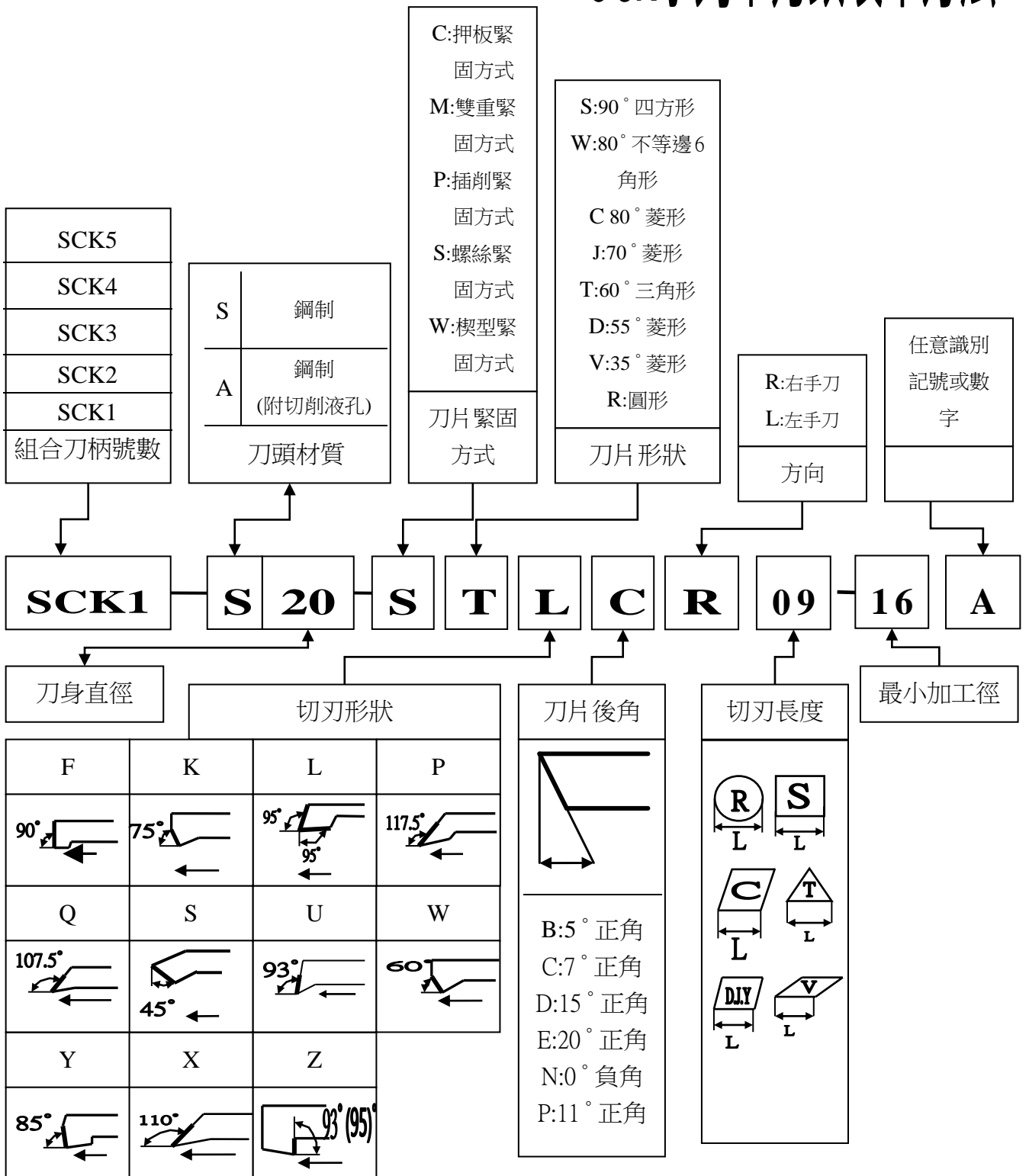



# Zy 模組化內徑車刀頭 Modular Internal Head With Coolant

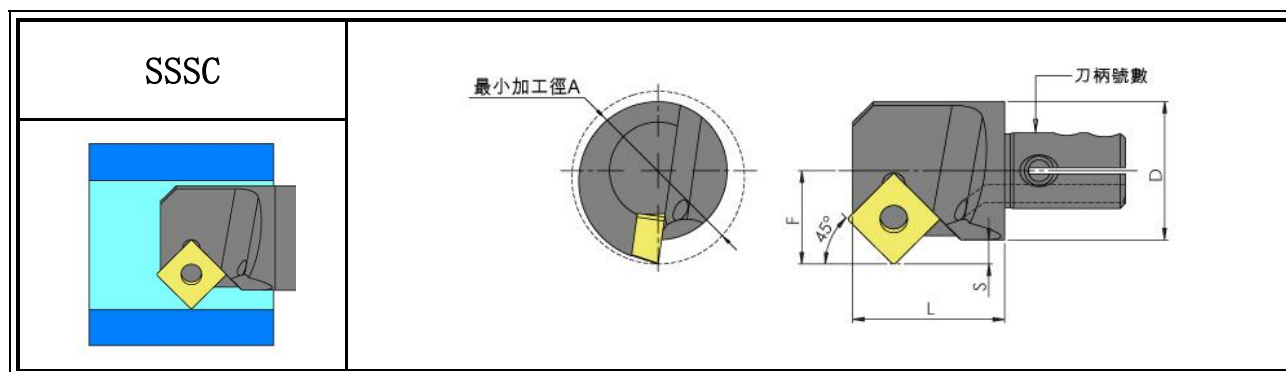

Stock	型號 Model No.	最小加工徑 A	F	D	L	S	螺絲 Screw	扳手 Wrench	刀片 Insert
●	SCK1-A20-SSSCR09-26	26	13.5	20	22	3.5	M4x8.8x5.4	T15	SC09T3
○	SCK2-A25-SSSCR09-31	31	16	25	27	3.5			
○	SCK3-A32-SSSCR09-40	40	19.5	32	30	3.5			

●:庫存 In Stock    ○:非標準庫存(請確認交貨期) Non-standard Stock

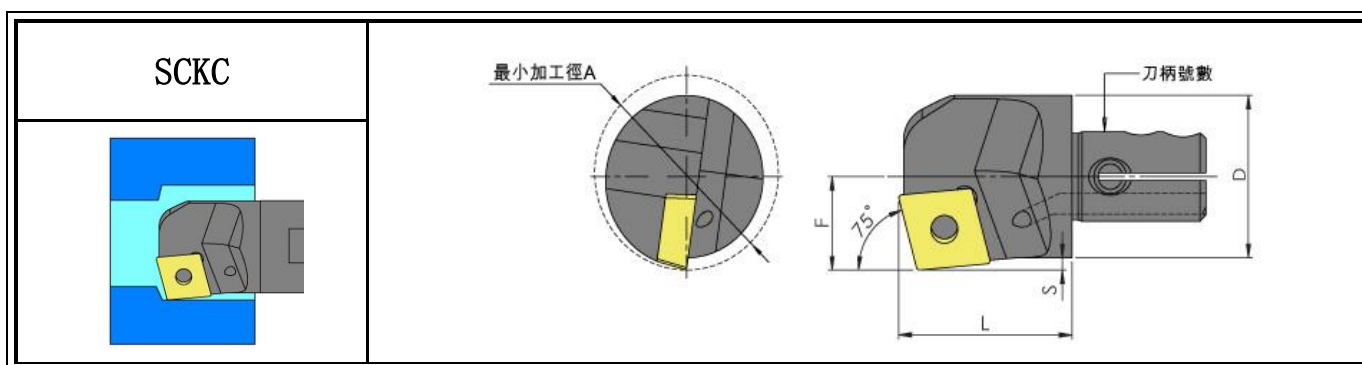

Stock	型號 Model No.	最小加工徑 A	F	D	L	螺絲 Screw	扳手 Wrench	刀片 Insert
○	SCK0-A16-SCKCR09-20	20	9	16	22	M4x8.8x5.4	T15	CC09T3
●	SCK1-A20-SCKCR09-24	24	11.5	20	22			
○	SCK2-A25-SCKCR09-30	30	15	25	25			
○	SCK3-A32-SCKCR09-38	38	17.5	32	30			

●:庫存 In Stock    ○:非標準庫存(請確認交貨期) Non-standard Stock

# Zy 模組化內徑車刀頭 Modular Internal Head With Coolant

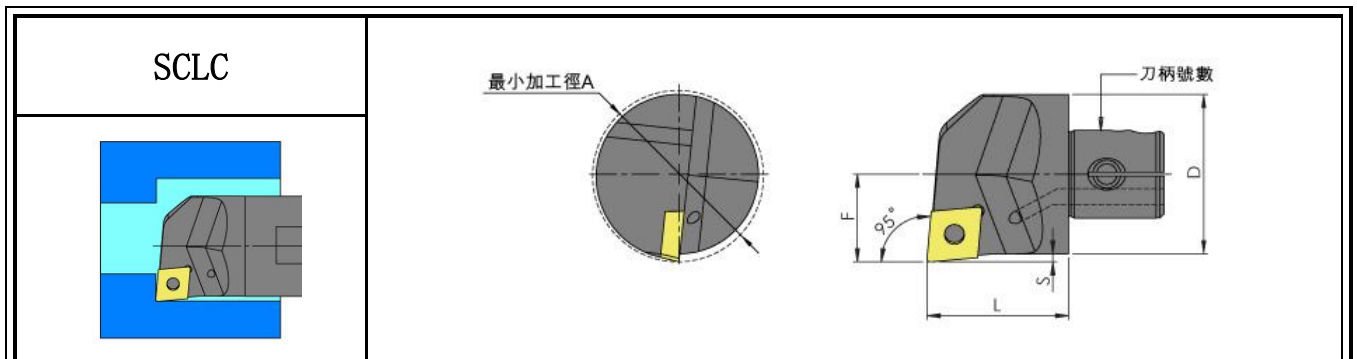

Stock	型號 Model No.	最小加工徑 A	F	D	L	 螺絲 Screw	 板手 Wrench	刀片 Insert
○	SCK0-A16-SCLCR09-18	18	9	16	22	M4x10.6x5.6	T15	CC09T3
●	SCK1-A20-SCLCR09-22	22	11	20	22			
●	SCK1-A20-SCLCR09-24	24	13	20	22			
●	SCK2-A25-SCLCR09-28	28	14.5	25	25			
●	SCK3-A32-SCLCR09-38	38	17.5	32	30			
●	SCK4-A40-SCLCR09-43	43	21	40	33			
●	SCK5-A50-SCLCR09-60	60	30	50	35			

●:庫存 In Stock    ○:非標準庫存(請確認交貨期) Non-standard Stock

# Zy 模組化內徑車刀頭 Modular Internal Head With Coolant

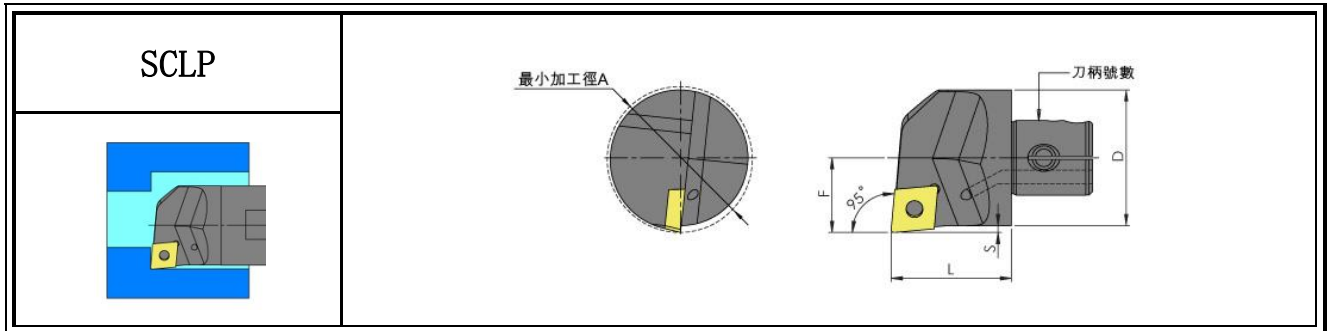

Stock	型號 Model No.	最小加工徑 A	F	D	L	螺絲 Screw	扳手 Wrench	刀片 Insert
○	SCK0-A16-SCLPR09-18	18	9	16	22	M4x8.8x5.4	T15	CP0903
●	SCK1-A20-SCLPR09-22	22	11	20	22			
●	SCK2-A25-SCLPR09-28	28	14	25	25			
○	SCK3-A32-SCLPR09-35	35	17.5	32	24			

●:庫存 In Stock    ○:非標準庫存(請確認交貨期) Non-standard Stock

# Zy 模組化內徑車刀頭 Modular Internal Head With Coolant

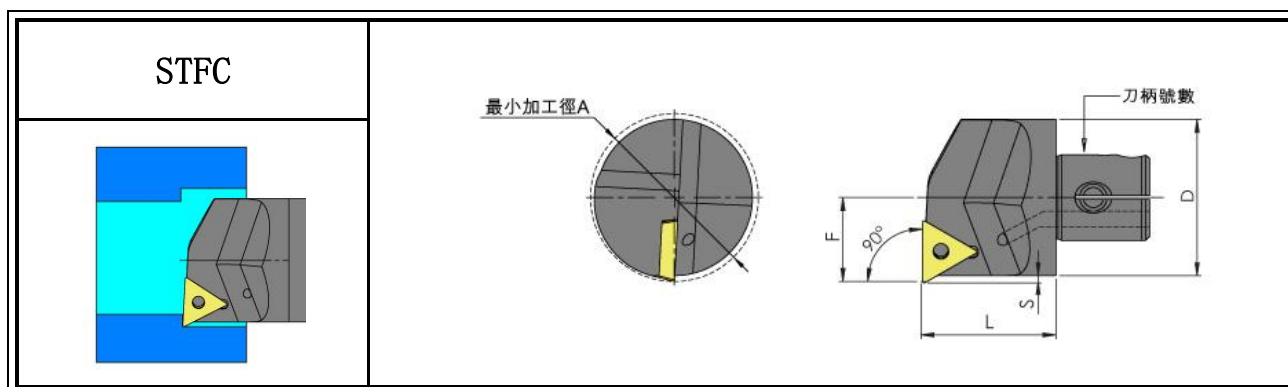

Stock	型號 Model No.	最小加工徑 A	F	D	L	螺絲 Screw	扳手 Wrench	刀片 Insert
○	SCK0-A16-STFCR11-18	18	9.5	16	22	M2.5x6.0x3.6	T8	TC1102
●	SCK1-A20-STFCR11-22	22	11	20	22			
●	SCK2-A25-STFCR11-28	28	14	25	25			
●	SCK1-A20-STFCR16T3-22	22	11.5	20	22	M4x8.8x5.4	T15	TC16T3
○	SCK2-A25-STFCR16T3-28	28	14	25	27			
●	SCK3-A32-STFCR16T3-35	35	17.5	32	30			
●	SCK4-A40-STFCR16T3-43	43	21.5	40	33			
○	SCK5-A50-STFCR16T3-53	53	27	50	35			

●:庫存 In Stock    ○:非標準庫存(請確認交貨期) Non-standard Stock

# Zy 模組化內徑車刀頭 Modular Internal Head With Coolant

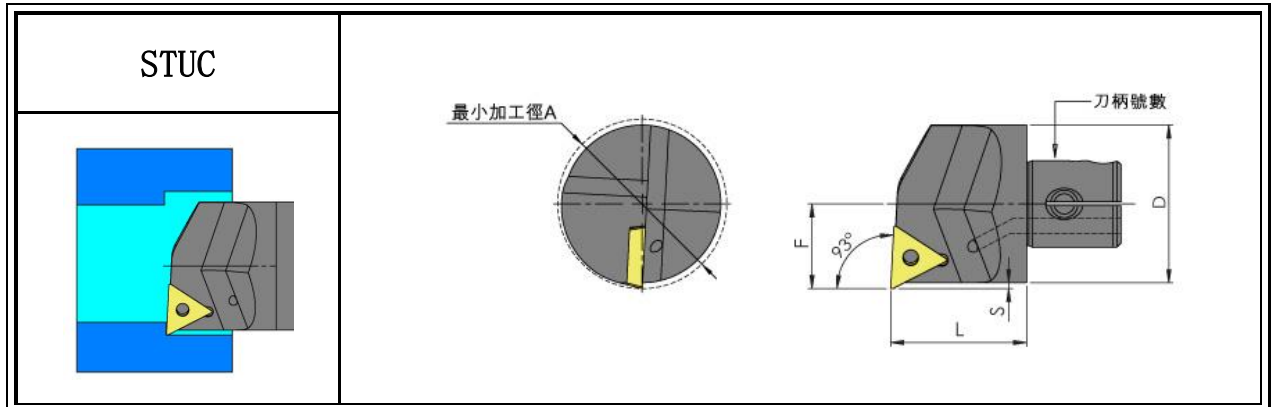

Stock	型號 Model No.	最小加工徑 A	F	D	L	螺絲 Screw	扳手 Wrench	刀片 Insert
○	SCK0-A16-STUCR11-18	18	9	16	22	M2.5x6.0x3.6	T8	TC1102
●	SCK1-A20-STUCR11-22	22	11	20	22			
●	SCK2-A25-STUCR11-28	28	14	25	25			
●	SCK1-A20-STUCR16T3-22	22	11	20	22	M4x8.8x5.4	T15	TC16T3
●	SCK2-A25-STUCR16T3-28	28	14	25	27			
●	SCK3-A32-STUCR16T3-38	38	17.5	32	30			
○	SCK4-A40-STUCR16T3-50	50	21.5	40	33			
○	SCK5-A50-STUCR16T3-60	60	26.5	50	35			

●:庫存 In Stock    ○:非標準庫存(請確認交貨期) Non-standard Stock

# Zy 模組化內徑車刀頭 Modular Internal Head With Coolant

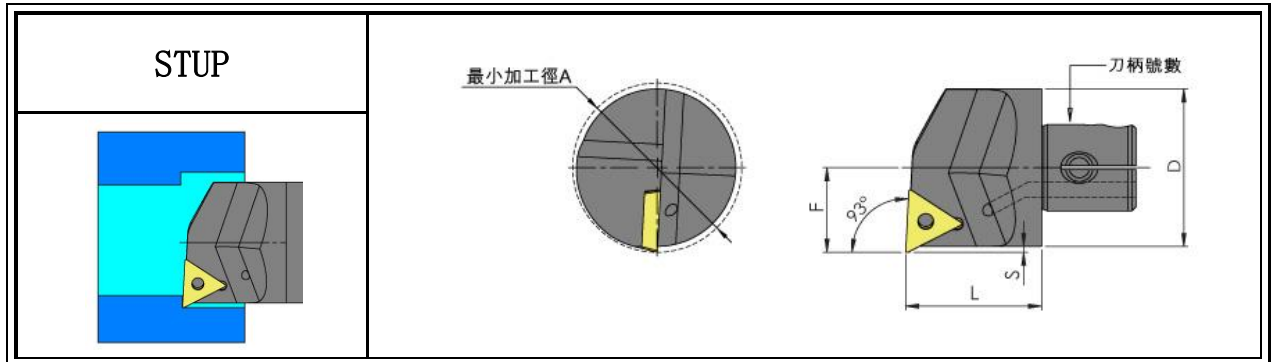

Stock	型號 Model No.	最小加工徑 A	F	D	L	螺絲 Screw	板手 Wrench	刀片 Insert
●	SCK1-A20-STUPR11-22	22	11.5	20	22	M3x7.8x4.1	T9	TP1103
●	SCK2-A25-STUPR11-30	30	15	25	25			
●	SCK3-A32-STUPR11-36	36	18.5	32	30			
●	SCK1-A20-STUPR1603-25	25	13	20	25.5	M4x8.8x5.4	T15	TP1603
●	SCK2-A25-STUPR1603-28	28	14	25	27			
●	SCK3-A32-STUPR1603-38	38	17.5	32	30			
○	SCK4-A40-STUPR1603-43	43	21.5	40	33			
○	SCK5-A50-STUPR1603-60	60	26.5	50	35			
●	SCK1-A20-STUPR16T3-25	25	13	20	25.5	M4x8.8-5.4	T15	TP16T3
●	SCK2-A25-STUPR16T3-28	28	14	25	27			
○	SCK3-A32-STUPR16T3-35	38	17.5	32	30			
○	SCK4-A40-STUPR16T3-50	50	21.5	40	33			
○	SCK5-A50-STUPR16T3-53	53	27	50	35			
●	SCK1-A20-STUPR1604-25	25	13	20	25.5	M4x8.8x5.6	T15	TP1604
●	SCK2-A25-STUPR1604-28	28	14	25	27			
●	SCK3-A32-STUPR1604-38	38	17.5	32	30			
●	SCK4-A40-STUPR1604-43	43	21.5	40	33			
○	SCK5-A50-STUPR1604-60	60	26.5	50	35			

●:庫存 In Stock    ○:非標準庫存(請確認交貨期) Non-standard Stock

# Zy 模組化內徑車刀頭 Modular Internal Head With Coolant

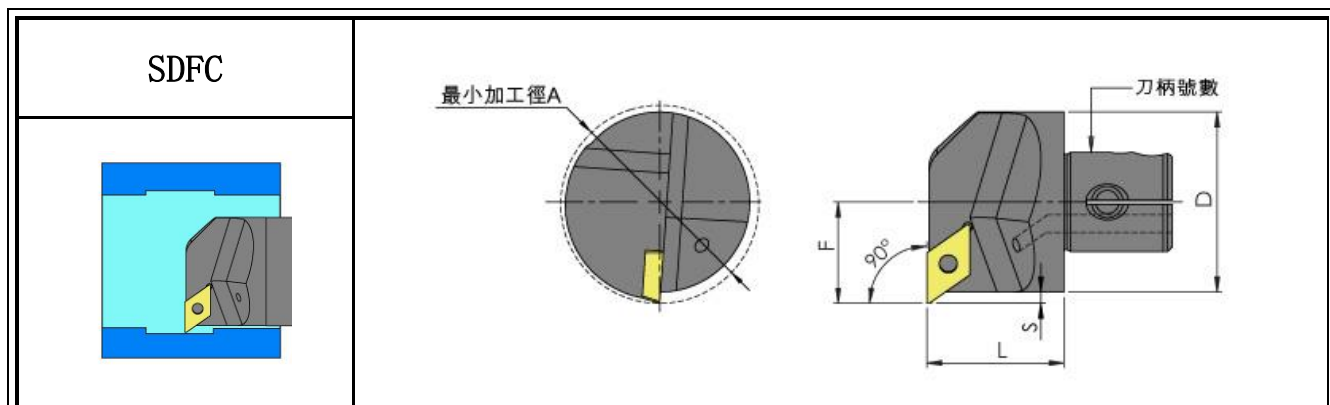

Stock	型號 Model No.	最小加工徑 A	F	D	L	S	螺絲 Screw	扳手 Wrench	刀片 Insert
●	SCK1-A20-SDFCR11-24	25	13	20	22	3	M4x8. 8x5. 4	T15	DC11T3
●	SCK2-A25-SDFCR11-32	32	17	25	27	3			
●	SCK3-A32-SDFCR11-36	36	18	32	27	2			
●	SCK4-A40-SDFCR11-44	44	22.5	40	27	2.5			

●:庫存 In Stock    ○:非標準庫存(請確認交貨期) Non-standard Stock

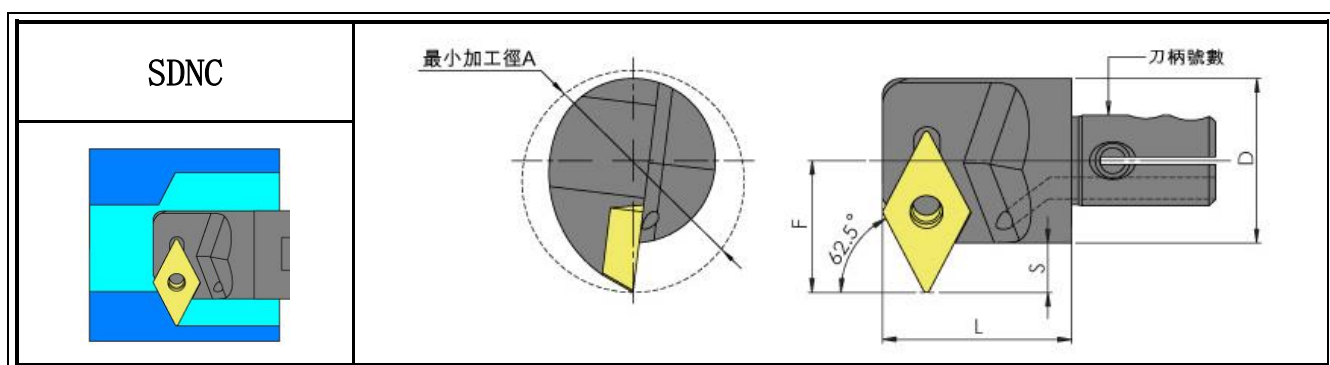

Stock	型號 Model No.	最小加工徑 A	F	D	L	S	螺絲 Screw	扳手 Wrench	刀片 Insert
●	SCK1-A20-SDNCR11-27	27	16	20	22	6	M4x8. 8x5. 4	T15	DC11T3
○	SCK2-A25-SDNCR11-32	32	18	25	27	5.5			
●	SCK3-A32-SDNCR11-38	38	20.5	32	30	4.5			

●:庫存 In Stock    ○:非標準庫存(請確認交貨期) Non-standard Stock

# Zy 模組化內徑車刀頭 Modular Internal Head With Coolant

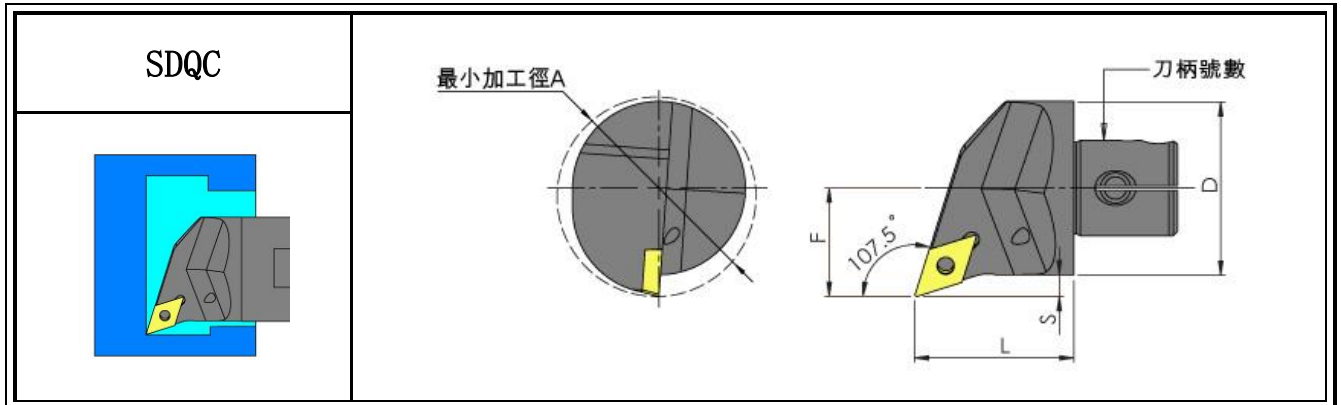

Stock	型號 Model No.	最小加工徑 A	F	D	L	S	螺絲 Screw	板手 Wrench	刀片 Insert
●	SCK1-A20-SDQCR11-25	25	13	20	22	3	M4x8. 8x5. 4	T15	DC11T3
●	SCK2-A25-SDQCR11-32	32	17	25	27	3			
●	SCK3-A32-SDQCR11-40	40	20	32	30	4			
●	SCK4-A40-SDQCR11-46	46	25	40	33	5			
●	SCK5-A50-SDQCR11-56	56	30	50	35	5			

●:庫存 In Stock    ○:非標準庫存(請確認交貨期) Non-standard Stock



# Zy 模組化內徑車刀頭 Modular Internal Head With Coolant

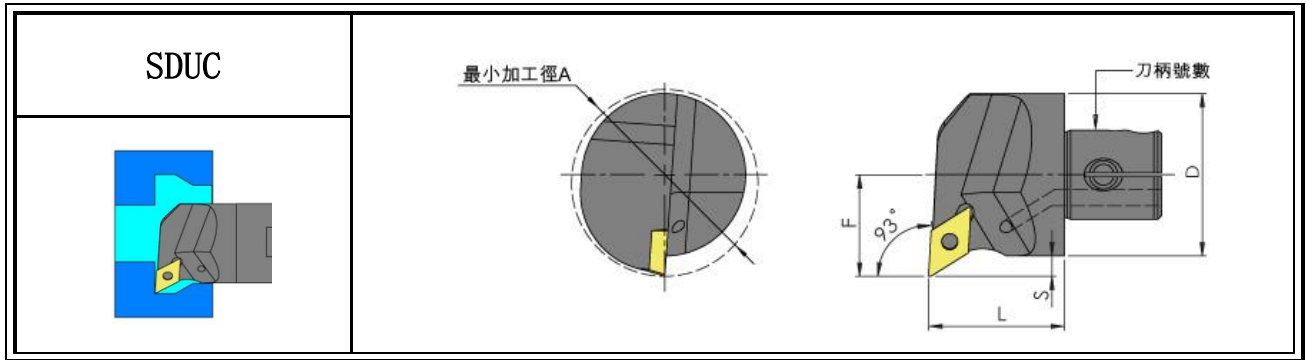

Stock	型號 Model No.	最小加工徑 A	F	D	L	S	螺絲 Screw	扳手 Wrench	刀片 Insert
●	SCK1-A20-SDUCR07-25	25	13	20	22	3	M2.5x6.0x3.6	T8	DC0702
●	SCK1-A20-SDUCR11-23	23	12.5	20	22	2.5	M4x8.8x5.4	T15	DC11T3
●	SCK1-A20-SDUCR11-25	25	13	20	22	3			
●	SCK2-A25-SDUCR11-32	32	17	25	25	4.5			
●	SCK3-A32-SDUCR11-37	37	20	32	30	4			
●	SCK4-A40-SDUCR11-46	46	25	40	33	5			
●	SCK5-A50-SDUCR11-56	56	30	50	35	5			

●:庫存 In Stock    ○:非標準庫存(請確認交貨期) Non-standard Stock

# Zy 模組化內徑車刀頭 Modular Internal Head With Coolant

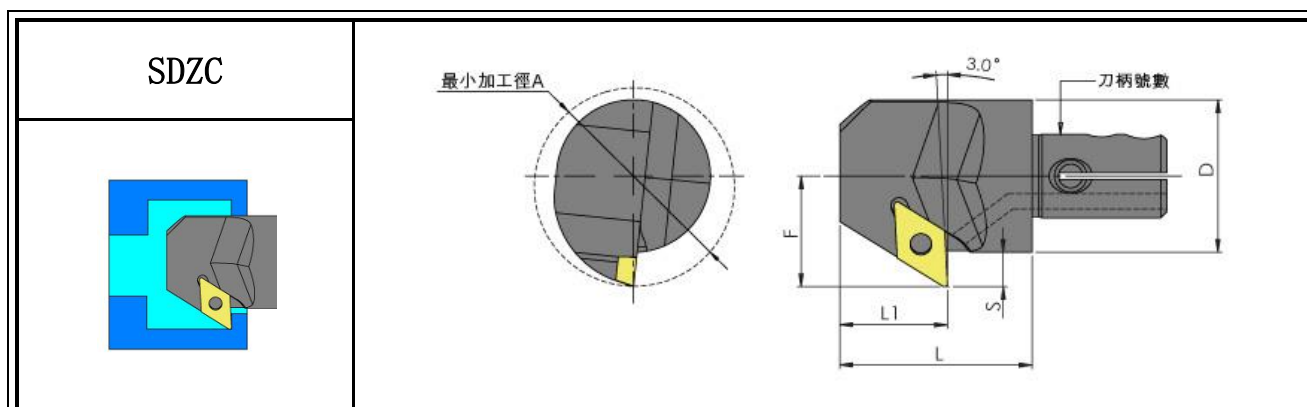

Stock	型號 Model No.	最小加工徑 A	F	D	L	L1	S	螺絲 Screw	扳手 Wrench	刀片 Insert
●	SCK1-A20-SDZCR11-26	26	15.5	20	29	18	5.5	M4x8.8x5.4	T15	DC11T3
●	SCK1-A20-SDZCR11-28	28	17	20	29	18	7.0			
●	SCK2-A25-SDZCR11-33	33	18	25	34	18	5.5			
●	SCK3-A32-SDZCR11-40	40	21.5	32	35	18	5.5			

●:庫存 In Stock    ○:非標準庫存(請確認交貨期) Non-standard Stock

# Zy 模組化內徑車刀頭 Modular Internal Head With Coolant

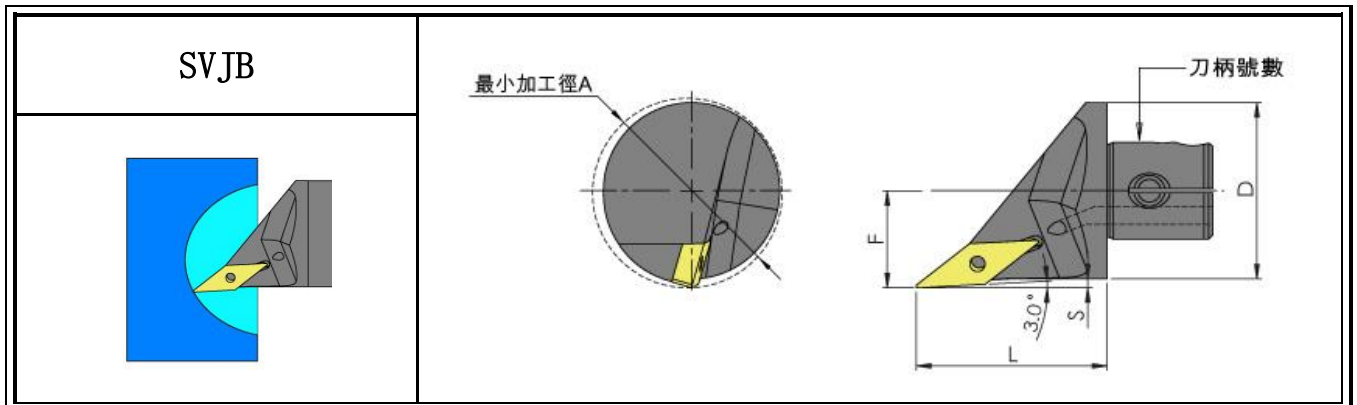

Stock	型號 Model No.	最小加工徑 A	F	D	L	S	螺絲 Screw	扳手 Wrench	刀片 Insert
●	SCK1-A20-SVJBR11-22	22	11	20	29	1	M2.5x6.0x3.6	T8	VB1103
●	SCK2-A25-SVJBR11-28	28	14	25	32	1.5			
●	SCK3-A32-SVJBR16-35	35	17.5	32	42	1.5	M3.5x12.0x5.4	T15	VB1604
●	SCK4-A40-SVJBR16-43	43	22	40	42	2			

●:庫存 In Stock    ○:非標準庫存(請確認交貨期) Non-standard Stock

# Zy 模組化內徑車刀頭 Modular Internal Head With Coolant

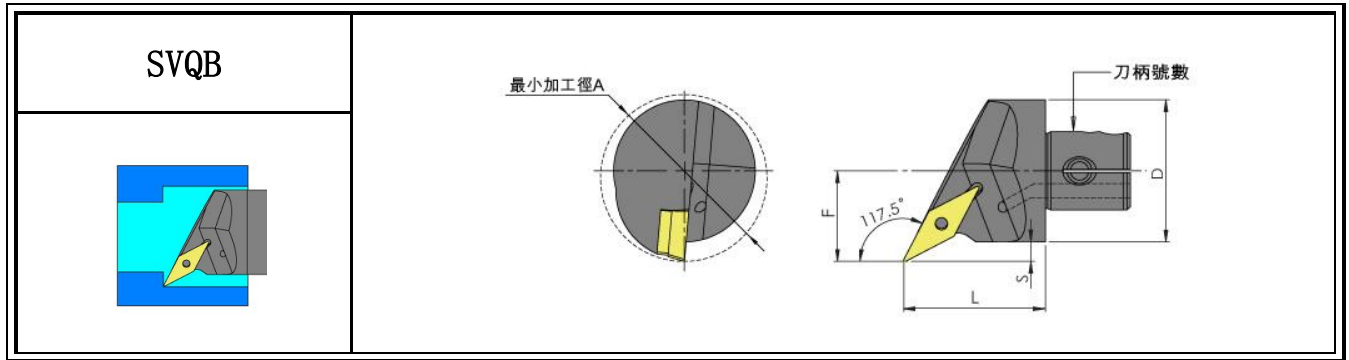

Stock	型號 Model No.	最小加工徑 A	F	D	L	S	墊片 Shim	螺絲 Screw	板手 Wrench	刀片 Insert
●	SCK1-A20-SVQBR11-25	25	14	20	25.5	4	-	M2.5x6.0x3.6	T8	VB1103
○	SCK2-A25-SVQBR11-32	32	18	25	27	5.5	-			
○	SCK1-A20-SVQBR16-25	25	14	20	25.5	4	-	M3.5x12.0x5.4	T15	VB1604
○	SCK2-A25-SVQBR16-32	32	18	25	27	5.5	-			
●	SCK3-A32-SVQBR16-37	37	20	32	32	4	-	M3.5x11.4x5.7	T15	VB1604
●	SCK4-A40-SVQBR16-47	47	26	40	42	6	VSS322			
●	SCK5-A32-SVQBR16-58	58	32	50	45	7				

●:庫存 In Stock    ○:非標準庫存(請確認交貨期) Non-standard Stock

# Zy 模組化內徑車刀頭 Modular Internal Head With Coolant

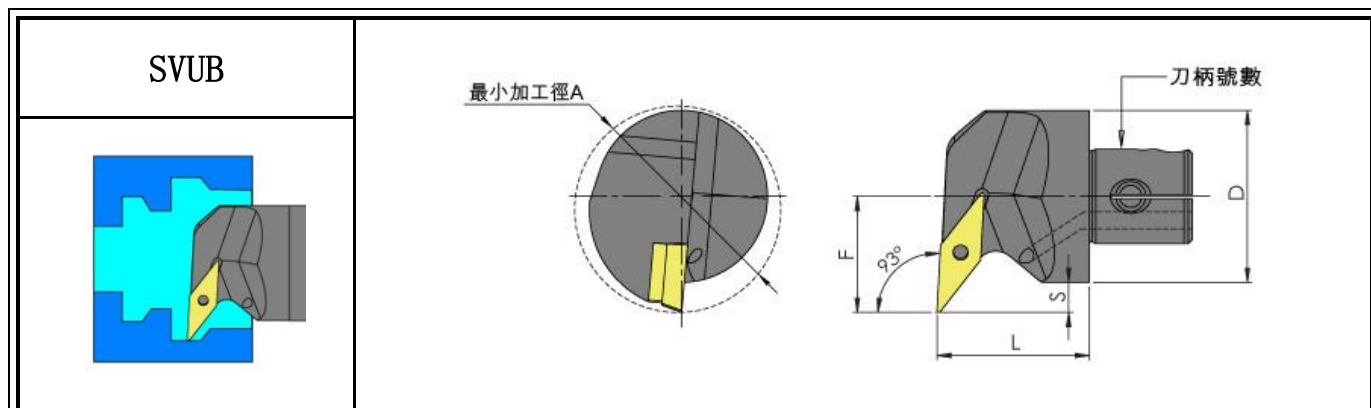

Stock	型號 Model No.	最小加工徑 A	F	D	L	S	墊片 Shim	螺絲 Screw	板手 Wrench	刀片 Insert
●	SCK1-A20-SVUBR11-27	27	15	20	22	5	-	M2.5x6.0x3.6	T8	VB1103
●	SCK1-A20-SVUBR16-31	31	19	20	27	9	-	M3.5x12.0x5.4	T15	VB1604
●	SCK2-A25-SVUBR16-33	33	18	25	27	5.5	-			
●	SCK3-A32-SVUBR16-40	40	22	32	30	6	-			
●	SCK3-A32-SVUBR16-40	40	23	32	30	7	VSS322	M3.5x11.4x5.7	T15	VB1604
●	SCK4-A40-SVUBR16-48	48	27	40	35	7				
●	SCK4-A40-SVUBR16-51	51	30	40	35	10				
●	SCK5-A50-SVUBR16-58	58	32	50	42	7				

●:庫存 In Stock    ○:非標準庫存(請確認交貨期) Non-standard Stock

# Zy 模組化內徑車刀頭 Modular Internal Head With Coolant

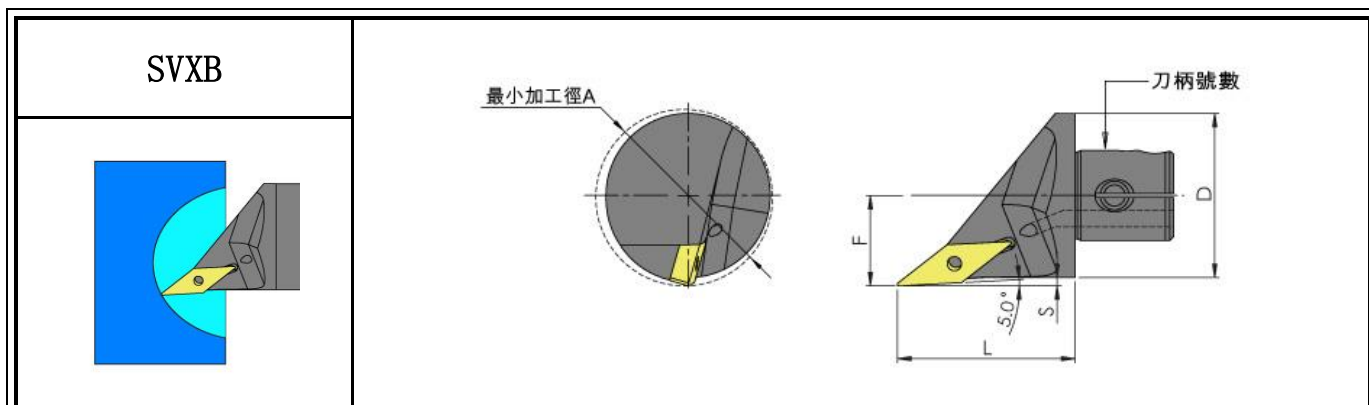

Stock	型號 Model No.	最小加工徑 A	F	D	L	S	螺絲 Screw	扳手 Wrench	刀片 Insert
●	SCK3-A32-SVXBR16-35	35	18	32	35	2	M3. 5x12. 0x5. 4	T15	VB1604
●	SCK4-A40-SVXBR16-43	43	25	40	36	5			
●	SCK5-A50-SVXBR16-53	53	27	50	45	2			

●:庫存 In Stock    ○:非標準庫存(請確認交貨期) Non-standard Stock

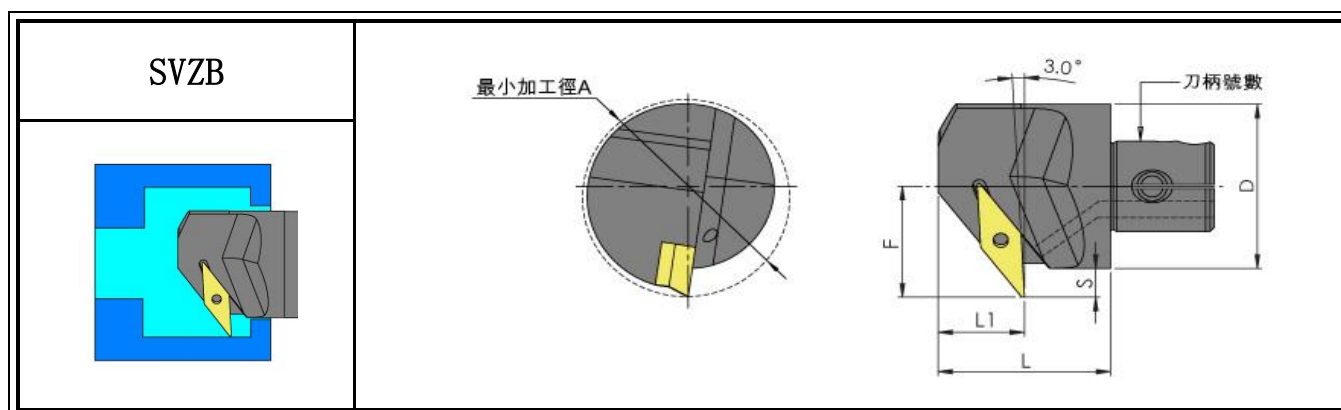

Stock	型號 Model No.	最小加工徑 A	F	D	L	L1	S	螺絲 Screw	扳手 Wrench	刀片 Insert
●	SCK1-A20-SVZBR11-25	25	14	20	25	12	4	M2. 5x6. 0x3. 6	T8	VB1103
○	SCK1-A20-SVZBR16-29	29	18	20	31	20	8	M3. 5x12. 0x5. 4	T15	VB1604
○	SCK2-A25-SVZBR16-35	35	21	25	36	20	8.5			
○	SCK3-A32-SVZBR16-42	42	23	32	41	19	7			

●:庫存 In Stock    ○:非標準庫存(請確認交貨期) Non-standard Stock

# Zy 模組化內徑車刀頭 Modular Internal Head With Coolant

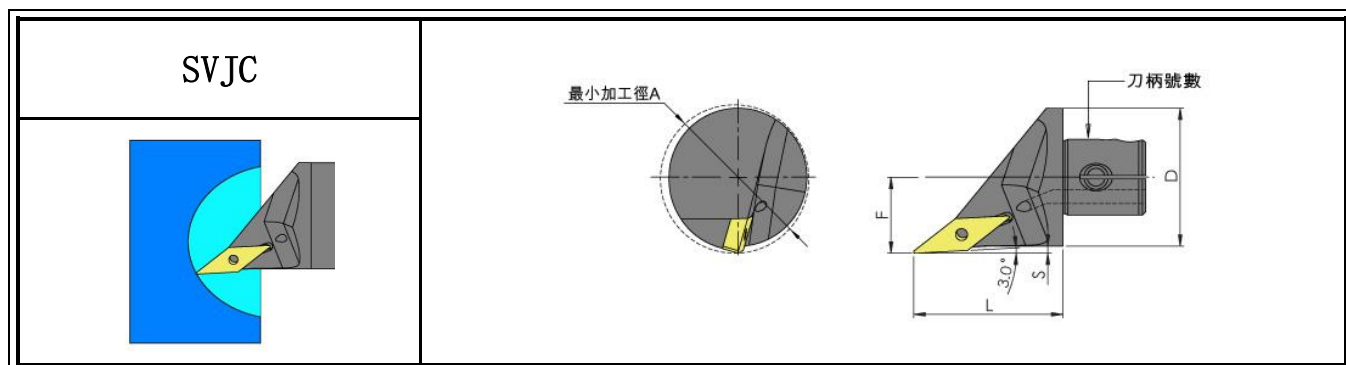

Stock	型號 Model No.	最小加工徑 A	F	D	L	 螺絲 Screw	 板手 Wrench	刀片 Insert
●	SCK1-A20-SVJCR11-22	22	11	20	29	M2.5x6.0x3.6	T8	VC1103
●	SCK1-A20-SVJCR16-23	23	11.5	20	33	M3.5x12.0x5.4	T15	VC1604
●	SCK2-A25-SVJCR16-28	28	14	25	35			
●	SCK3-A32-SVJCR16-35	35	17.5	32	39			

●:庫存 In Stock    ○:非標準庫存(請確認交貨期) Non-standard Stock

# Zy 模組化內徑車刀頭 Modular Internal Head With Coolant

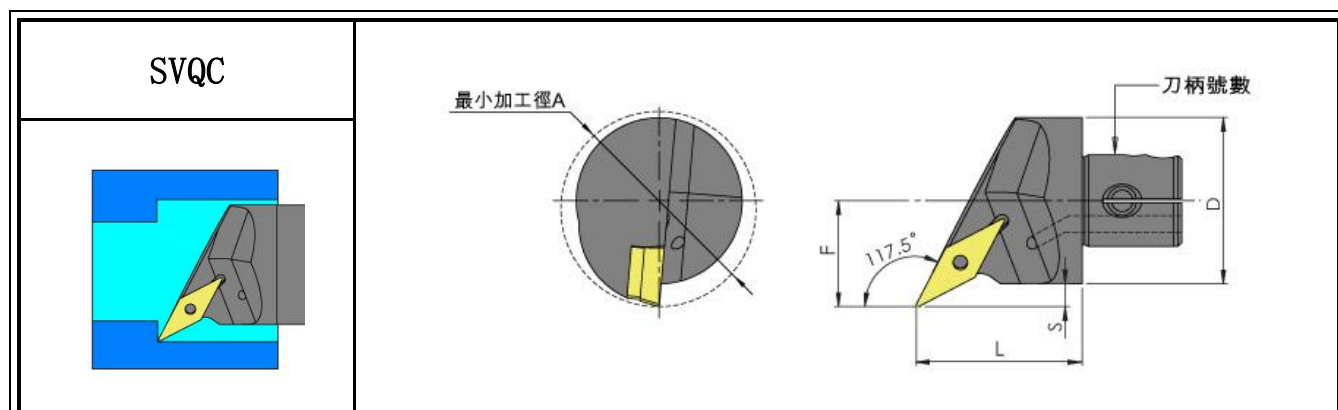

Stock	型號 Model No.	最小加工徑 A	F	D	L	S	墊片 Shim	螺絲 Screw	板手 Wrench	刀片 Insert
●	SCK1-A20-SVQCR11-25	25	14	20	25.5	4	-	M2.5x6.0x3.6	T8	VC1103
●	SCK2-A25-SVQCR11-32	32	18	25	27	5.5	-			
○	SCK1-A20-SVQCR16-25	25	14	20	25.5	4	-	M3.5x12.0x5.4	T15	VC1604
●	SCK2-A25-SVQCR16-32	32	18	25	27	5.5	-			
●	SCK3-A32-SVQCR16-37	37	20	32	32	4	-			
●	SCK4-A40-SVQCR16-47	47	26	40	42	6	VSS322	M3.5x11.4x5.7		
●	SCK5-A32-SVQCR16-58	58	32	50	45	7				

●:庫存 In Stock    ○:非標準庫存(請確認交貨期) Non-standard Stock



# Zy 模組化內徑車刀頭 Modular Internal Head With Coolant

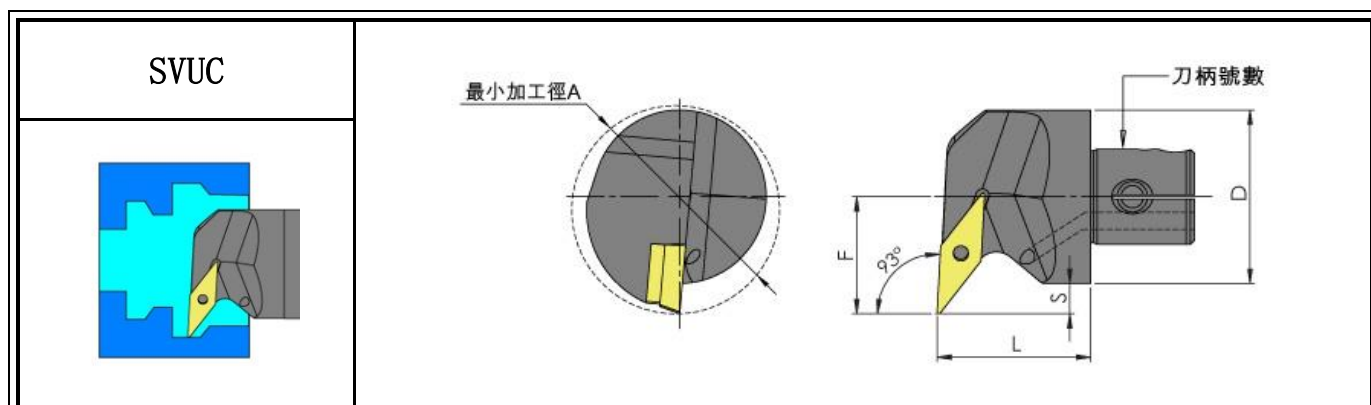

Stock	型號 Model No.	最小加工徑 A	F	D	L	S	墊片 Shim	螺絲 Clamp Screw	扳手 Wrench	刀片 Insert
●	SCK1-A20-SVUCR11-27	27	15	20	22	5	-	M2.5x6.0x3.6	T8	VC1103
●	SCK2-A25-SVUCR11-31	31	17	25	25	4.5	-			
●	SCK1-A20-SVUCR16-31	31	19	20	27	9	-	M3.5x12.0x5.4	T15	VC1604
●	SCK2-A25-SVUCR16-33	33	18	25	27	5.5	-			
●	SCK2-A25-SVUCR16-35	35	20	25	27	7.5	-			
●	SCK3-A32-SVUCR16-40	40	22	32	30	6	-			
●	SCK4-A40-SVUCR16-48	48	27	40	33	7	-			
●	SCK5-A50-SVUCR16-58	58	32	50	42	7	VSS322	M3.5x11.4x5.7		

●:庫存 In Stock    ○:非標準庫存(請確認交貨期) Non-standard Stock

# Zy 模組化內徑車刀頭 Modular Internal Head With Coolant

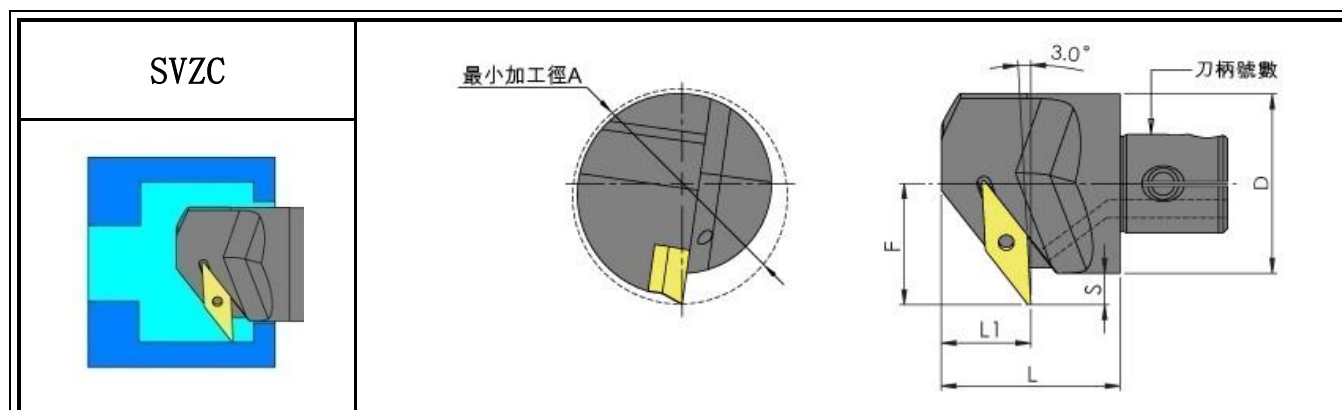

Stock	型號 Model No.	最小加工徑 A	F	D	L	L1	S	墊片 Shim	螺絲 Screw	板手 Wrench	刀片 Insert
●	SCK2-A25-SVZCR16-34	34	19.5	25	36	20	7	-	M3.5x11.4x5.7	T15	VC1604
●	SCK3-A32-SVZCR16-40	40	23	32	41	19	7	VSS322	M3.5x12.0x5.4		
●	SCK4-A40-SVZCR16-48	48	27	40	40	20	7				
●	SCK5-A50-SVZCR16-58	58	32	50	45	22	7				

●:庫存 In Stock    ○:非標準庫存(請確認交貨期) Non-standard Stock

# Zy 模組化內徑車刀頭 Modular Internal Head With Coolant

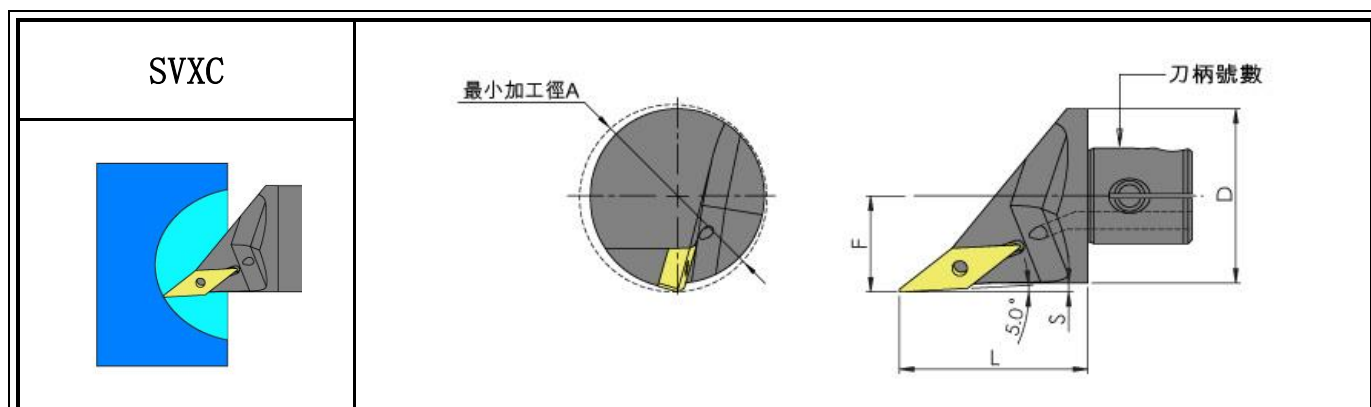

Stock	型號 Model No.	最小加工徑 A	F	D	L	S	螺絲 Screw	扳手 Wrench	刀片 Insert
●	SCK1-A20-SVXCR11-22	22	11	20	28	1	M2.5x6.0x3.6	T8	VC1103
○	SCK2-A25-SVXCR11-28	28	14	25	29	1.5			
○	SCK3-A32-SVXCR11-34	34	17	32	29	1			
○	SCK4-A40-SVXCR11-42	42	21	40	29	1			
○	SCK5-A50-SVXCR11-52	52	26	50	29	1			
●	SCK2-A25-SVXCR16-28	28	14	25	35	1.5	M3.5x12.0x5.4	T15	VC1604
○	SCK3-A32-SVXCR16-35	35	18	32	35	2			
●	SCK4-A40-SVXCR16-43	43	22	40	35	2			
○	SCK5-A50-SVXCR16-52	52	26	50	35	1			

●:庫存 In Stock    ○:非標準庫存(請確認交貨期) Non-standard Stock

# Zy 模組化內徑車刀頭 Modular Internal Head With Coolant

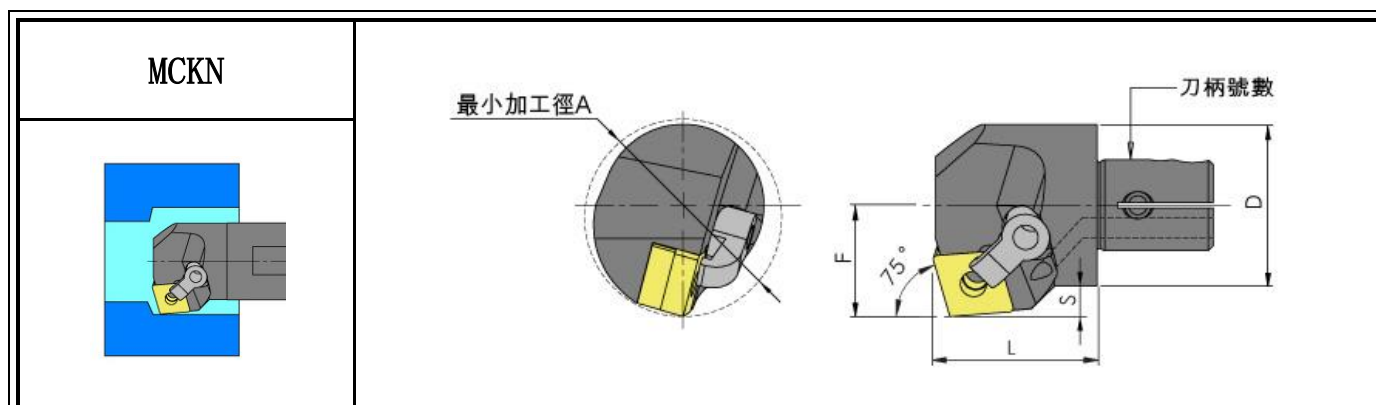

Stock	型號 Model No.	最小加工徑 A	F	D	L	S	墊片 Shim	偏心螺絲 Shim Screw	壓板 Clamp	雙頭螺絲 Clamp Screw	板手 Wrench
●	SCK3-A32-MCKNR12-39	39	22	32	35	6	CMS432	LCS-617	CP50-22	MS625	L2.5 L3.0
●	SCK4-A40-MCKNR12-46	46	25	40	35	5					
	SCK5-A50-MCKNR12-60	60	30	50	36	5					

刀片 Insert : CNMG1204

●:庫存 In Stock    ○:非標準庫存(請確認交貨期) Non-standard Stock

# Zy 模組化內徑車刀頭 Modular Internal Head With Coolant

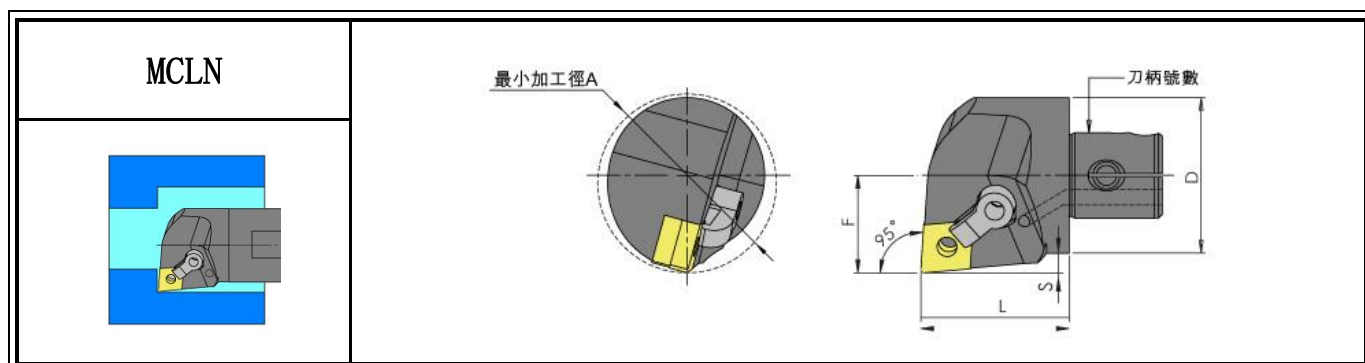

Stock	型號 Model No.	最小加工徑 A	F	D	L	S	墊片 Shim	偏心螺絲 Shim Screw	壓板 Clamp	雙頭螺絲 Clamp Screw	扳手 Wrench
●	SCK1-A20-MCLNR12-25	25	13	20	33	3	-	LCS-511	CP50-12	MS520	L2.5
●	SCK2-A25-MCLNR12-32	32	17	25	34	4.5	-	LCS-511	CP50-22	MS620	L2.5 L3.0
●	SCK3-A32-MCLNR12-40	40	20	32	35	4	CMS432	LCS-617	CP50-22	MS620	L3.0
●	SCK4-A40-MCLNR12-46	46	25	40	35	5		LCS-617	CP50-22	MS625	
●	SCK5-A50-MCLNR12-60	60	30	50	36	5		LCS-617	CP50-22	MS625	

刀片 Insert : CNMG1204

●:庫存 In Stock    ○:非標準庫存(請確認交貨期) Non-standard Stock

# Zy 模組化內徑車刀頭 Modular Internal Head With Coolant

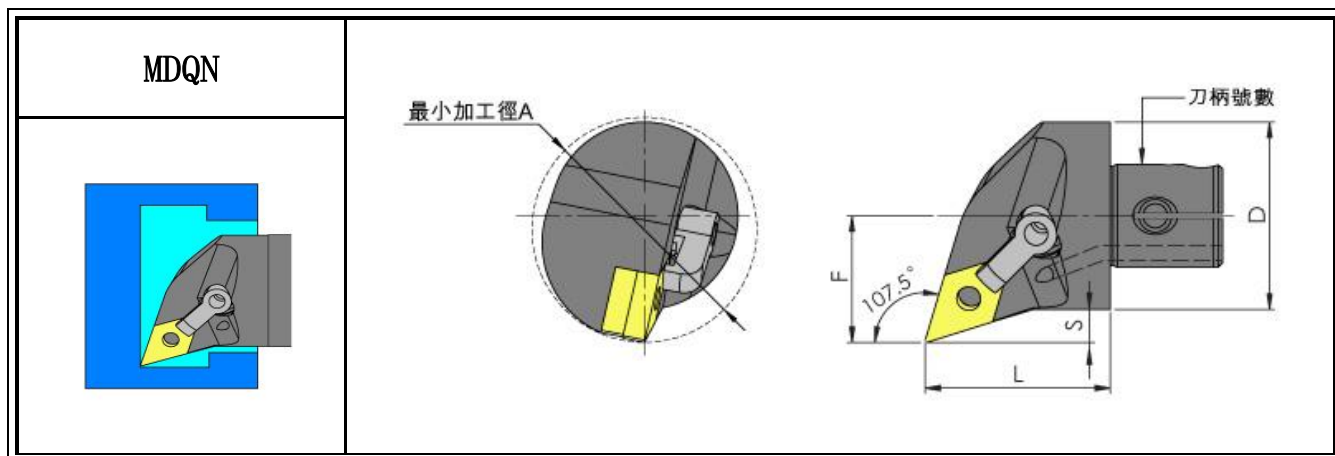

Stock	型號 Model No.	最小加工徑 A	F	D	L	S	墊片 Shim	偏心螺絲 Shim Screw	壓板 Clamp	雙頭螺絲 Clamp Screw	板手 Wrench
○	SCK2-A25-MDQNR15-32	32	16	25	36	3.5	-	LCS-617	CP50-24	MS625	L3.0
●	SCK3-A32-MDQNR15-39	39	22	32	39	6	DMS442				
●	SCK4-A40-MDQNR15-48	48	27	40	42	7					
●	SCK5-A50-MDQNR15-58	58	32	50	45	7					

刀片 Insert : DN1504

●:庫存 In Stock    ○:非標準庫存(請確認交貨期) Non-standard Stock

# Zy 模組化內徑車刀頭 Modular Internal Head With Coolant

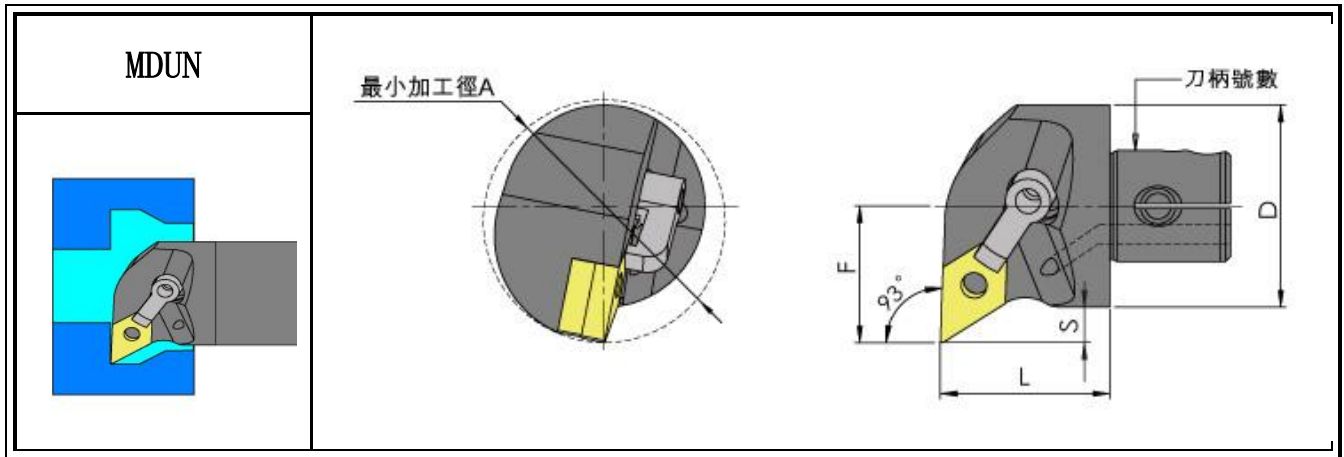

Stock	型號 Model No.	最小加工徑 A	F	D	L	S	墊片 Shim	偏心螺絲 Shim Screw	壓板 Clamp	雙頭螺絲 Clamp Screw	板手 Wrench
○	SCK2-A25-MDUNR15-32	32	16	25	36	3.5	-	LCS-617	CP50-24	MS625	L3.0
●	SCK3-A32-MDUNR15-39	39	22	32	39	6	DMS442				
●	SCK4-A40-MDUNR15-48	48	27	40	42	7					
●	SCK5-A50-MDUNR15-60	60	32	50	45	7					

刀片 Insert : DN1504

●: 庫存      ○: 非標準庫存 (請確認交貨期)

# Zy 模組化內徑車刀頭

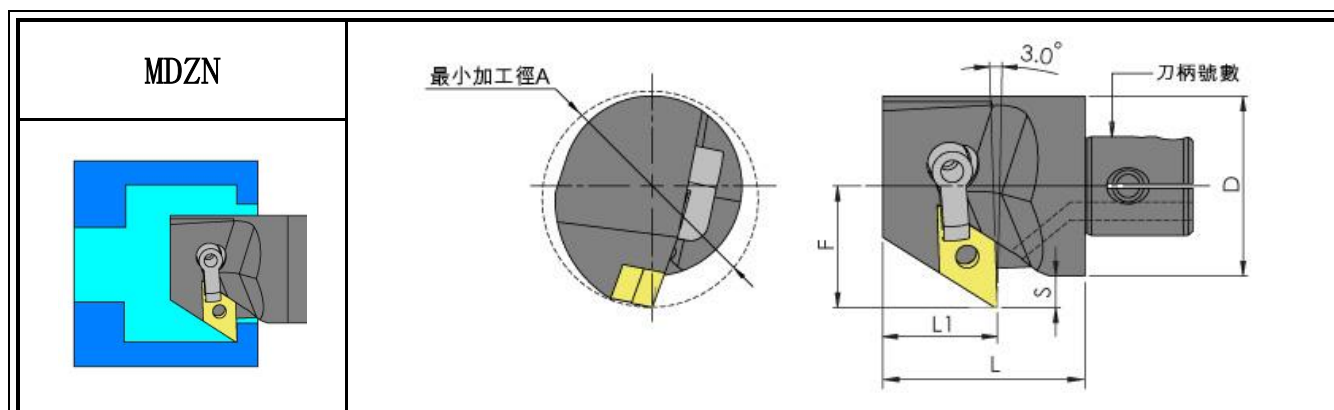

Stock	型號 Model No.	最小加工徑 A	F	D	L	S	墊片 Shim	偏心螺絲 Shim Screw	壓板 Clamp	雙頭螺絲 Clamp Screw	板手 Wrench
●	SCK3-A32-MDZNR15-39	39	22	32	39	6	DMS442	LCS-617	CP50-24	MS625	L3.0
●	SCK4-A40-MDZNR15-48	48	27	40	42	7					
	SCK5-A50-MDZNR15-59	59	32.5	50	45	7.5					

刀片 Insert : DN1504

●:庫存 In Stock    ○:非標準庫存(請確認交貨期) Non-standard Stock



# Zy 模組化內徑車刀頭 Modular Internal Head With Coolant

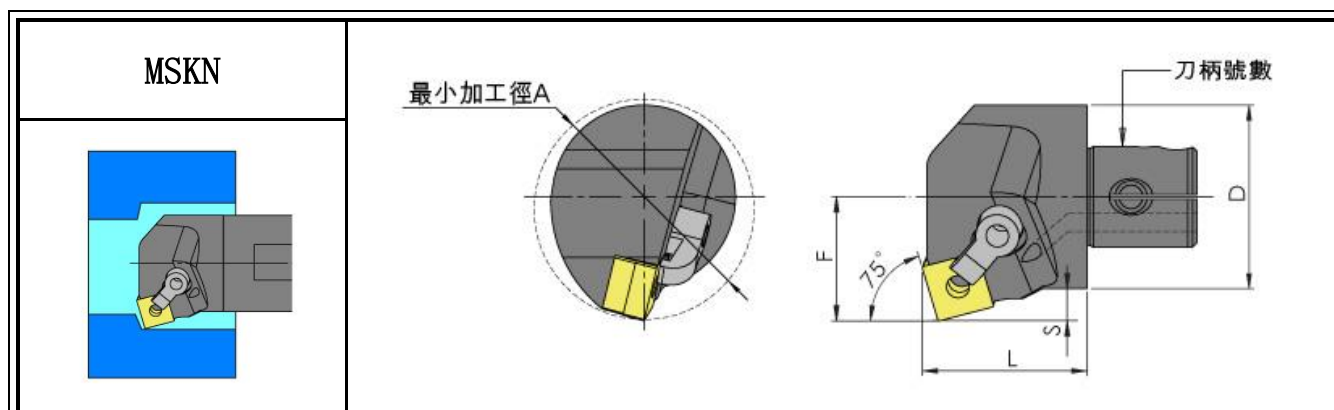

Stock	型號 Model No.	最小加工徑 A	F	D	L	S	墊片 Shim	偏心螺絲 Shim Screw	壓板 Clamp	雙頭螺絲 Clamp Screw	板手 Wrench
●	SCK3-A32-MSKNR12-39	39	22	32	39	6	GMS432	LCS-617	CP50-22	MS625	L3.0
●	SCK4-A40-MSKNR12-48	48	27	40	42	7					
●	SCK5-A50-MSKNR12-59	59	32.5	50	45	7.5					

刀片 Insert : SN1204

●:庫存 In Stock    ○:非標準庫存(請確認交貨期) Non-standard Stock

# Zy 模組化內徑車刀頭 Modular Internal Head With Coolant

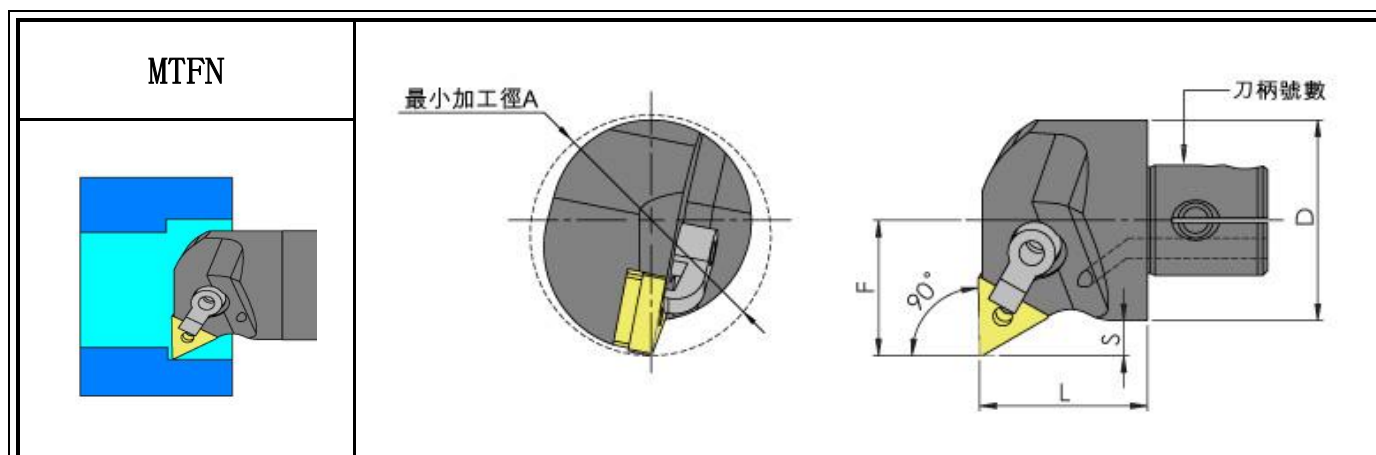

Stock	型號 Model No.	最小加工徑 A	F	D	L	S	墊片 Shim	偏心螺絲 Shim Screw	壓板 Clamp	雙頭螺絲 Clamp Screw	扳手 Wrench
●	SCK3-A32-MTFNR16-39	39	22	32	35	6	TMS322	LCS-513	CP50-22	MS625	L2.0 L3.0
●	SCK4-A40-MTFNR16-48	48	27	40	35	7					
●	SCK5-A50-MTFNR16-57	57	31	50	36	6					

刀片 Insert : TN1604

●:庫存 In Stock    ○:非標準庫存(請確認交貨期) Non-standard Stock

# Zy 模組化內徑車刀頭 Modular Internal Head With Coolant

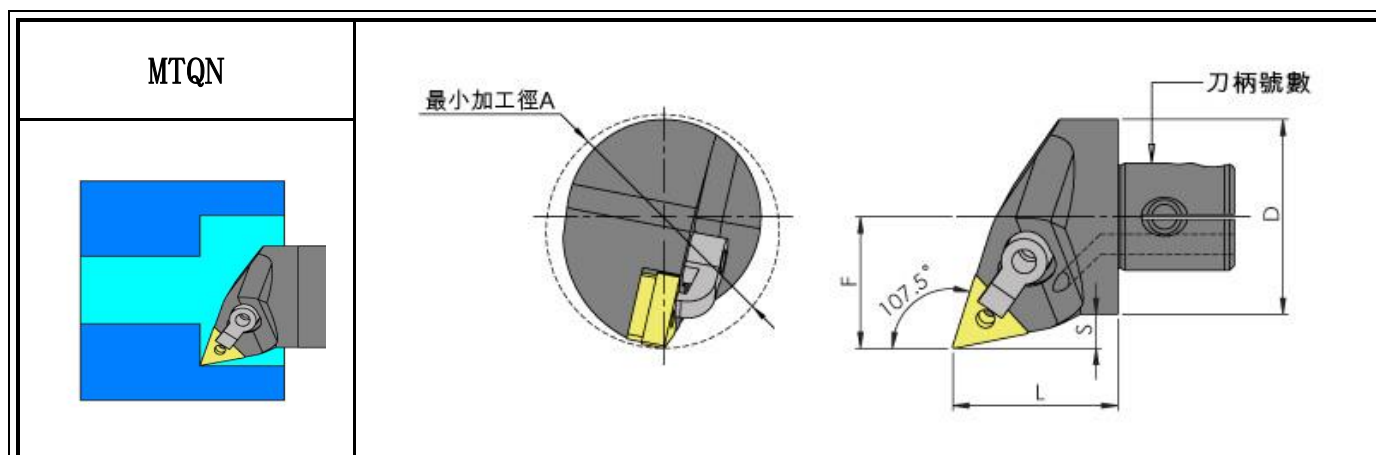

Stock	型號 Model No.	最小加工徑 A	F	D	L	S	墊片 Shim	偏心螺絲 Shim Screw	壓板 Clamp	雙頭螺絲 Clamp Screw	板手 Wrench
○	SCK1-A20-MTQNR16-25	25	13	20	29	3	-	LCS-510	CP50-12	MS520	L2.0 L2.5
●	SCK2-A25-MTQNR16-29	29	12.5	25	29	2.5	-	LCS-510	CP50-22	MS625	L2.0 L3.0
○	SCK3-A32-MTQNR16-40	40	22.5	32	35	6.5	TMS322	LCS-513	CP50-22	MS625	L2.0 L3.0
●	SCK4-A40-MTQNR16-48	48	27	40	35	7					
●	SCK5-A50-MTQNR16-57	57	31	50	36	6					

刀片 Insert : TN1604

●:庫存 In Stock    ○:非標準庫存(請確認交貨期) Non-standard Stock

# Zy 模組化內徑車刀頭 Modular Internal Head With Coolant

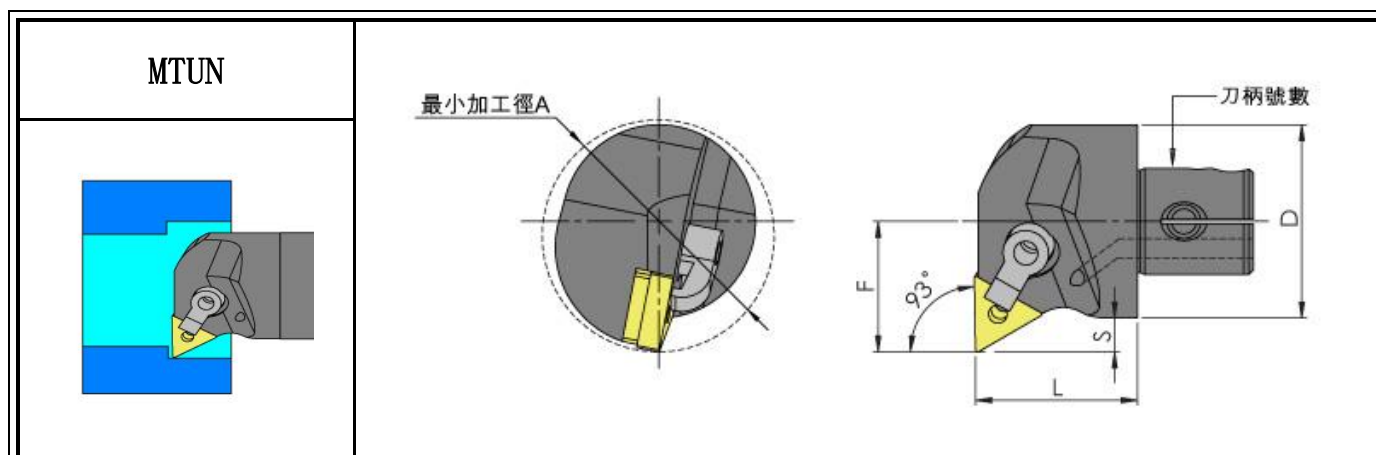

Stock	型號 Model No.	最小加工徑 A	F	D	L	S	墊片 Shim	偏心螺絲 Shim Screw	壓板 Clamp	雙頭螺絲 Clamp Screw	板手 Wrench
●	SCK1-A20-MTUNR16-25A	25	13	20	29	3	-	LCS-510	CP50-12	MS520	L2.0 L2.5
●	SCK2-A25-MTUNR16-32A	32	17	25	30	4.5	-	LCS-510	CP50-22	MS620	L2.0 L3.0
●	SCK3-A32-MTUNR16-40A	40	20	32	34	4	TMS322	LCS-513		MS625	
●	SCK4-A40-MTUNR16-47A	47	26	40	35	6					
●	SCK5-A50-MTUNR16-57A	57	31	50	45	7					

刀片 Insert : TN1604

●:庫存 In Stock    ○:非標準庫存(請確認交貨期) Non-standard Stock

# Zy 模組化內徑車刀頭 Modular Internal Head With Coolant

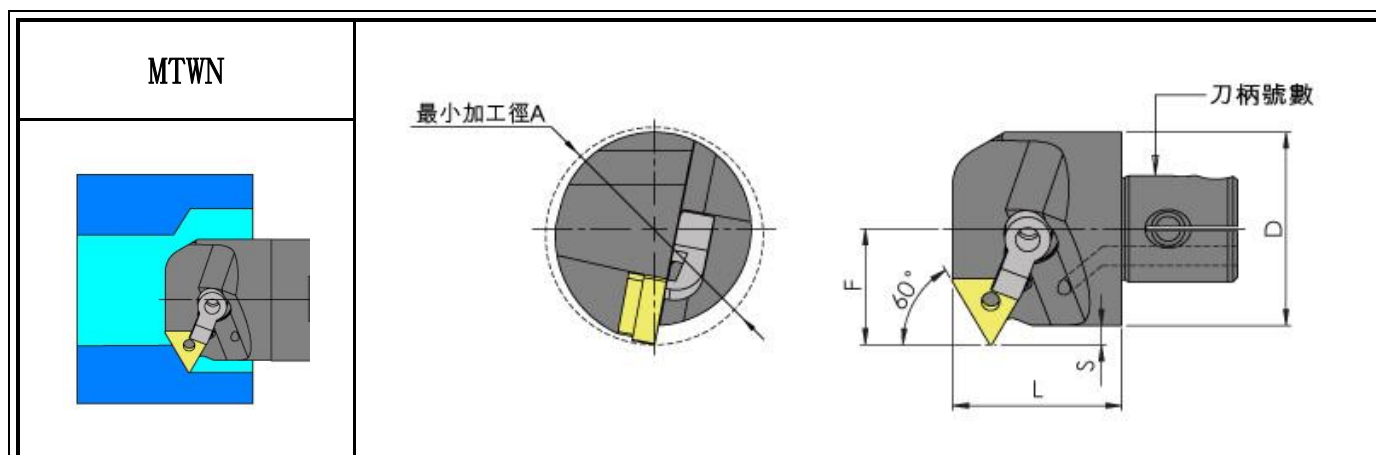

Stock	型號 Model No.	最小加工徑 A	F	D	L	S	墊片 Shim	偏心螺絲 Shim Screw	壓板 Clamp	雙頭螺絲 Clamp Screw	板手 Wrench
●	SCK3-A32-MTWR16-37	40	20	32	35	4	TMS322	LCS-513	CP50-22	MS625	L2.0 L3.0
●	SCK4-A40-MTWR16-45	48	24	40	35	4					
●	SCK5-A50-MTWR16-55	57	29	50	36	4					

刀片 Insert : TN1604

●:庫存 In Stock    ○:非標準庫存(請確認交貨期) Non-standard Stock

# Zy 模組化內徑車刀頭

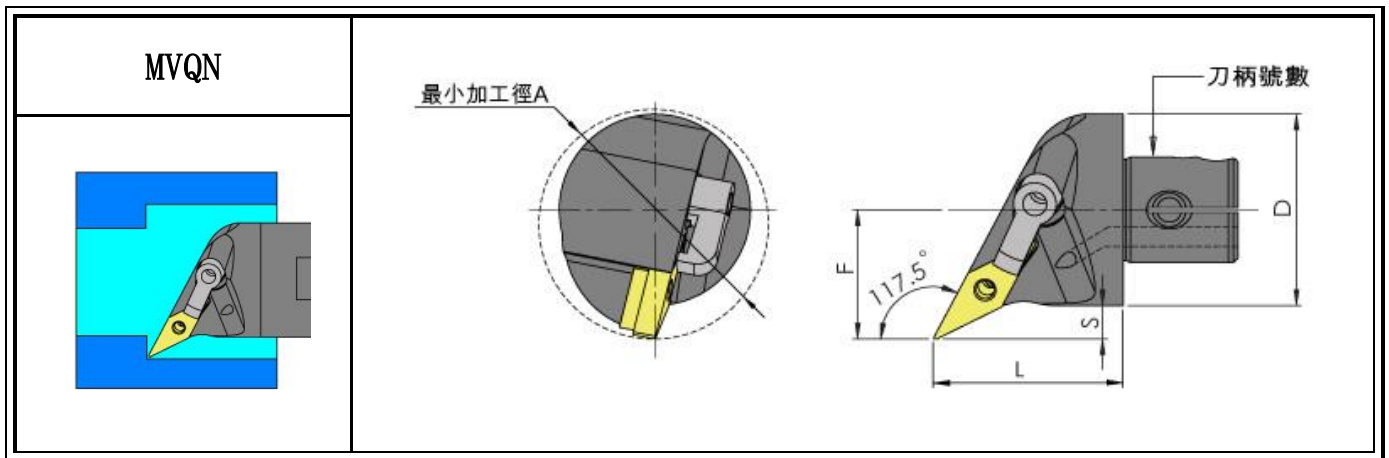

Stock	型號 Model No.	最小加工徑 A	F	D	L	S	墊片 Shim	偏心螺絲 Shim Screw	壓板 Clamp	雙頭螺絲 Clamp Screw	板手 Wrench
○	SCK2-A25-MVQNR16-32	32	20	25	35	7.5	-	LCS-513	CP50-24	MS625	L2.0 L3.0
●	SCK3-A32-MVQNR16-40	40	23	32	35	7					
●	SCK4-A40-MVQNR16-48	48	27	40	35	7					
●	SCK5-A50-MVQNR16-59	59	33	50	35	8					

刀片 Insert : VN1604

●:庫存 In Stock    ○:非標準庫存(請確認交貨期) Non-standard Stock

# Zy 模組化內徑車刀頭 Modular Internal Head With Coolant

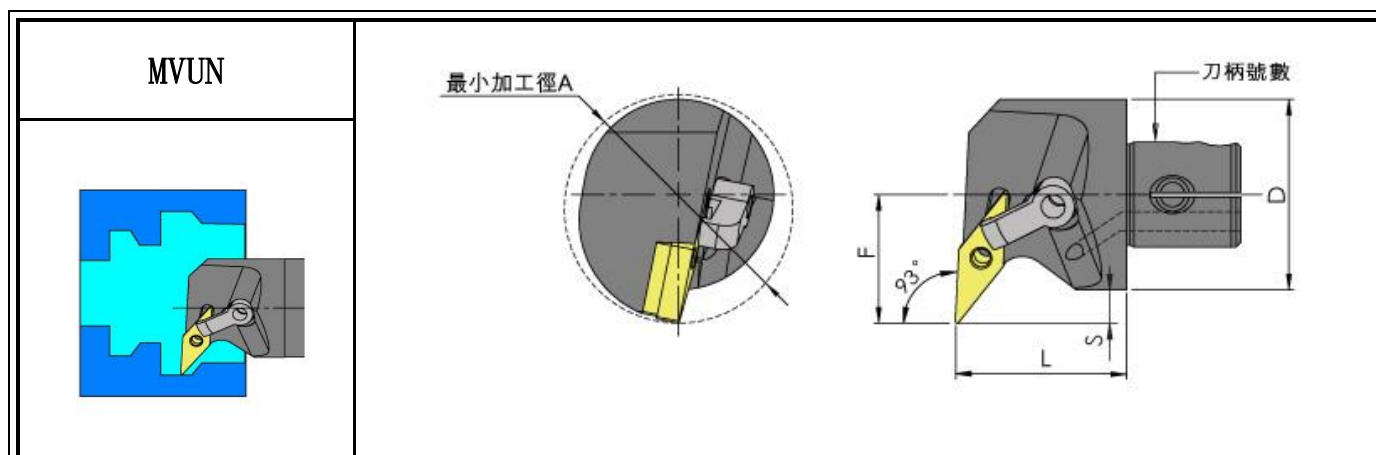

Stock	型號 Model No.	最小加工徑 A	F	D	L	S	墊片 Shim	偏心螺絲 Shim Screw	壓板 Clamp	雙頭螺絲 Clamp Screw	板手 Wrench
●	SCK2-A25-MVUNR16-32	32	18	25	35	5.5	-	LCS-513	CP50-24	MS625	P2.0 P3.0
●	SCK3-A32-MVUNR16-39	39	23	32	35	6	GMV322				
●	SCK4-A40-MVUNR16-48	48	27	40	35	7					
●	SCK5-A50-MVUNR16-59	59	33	50	35	8					

刀片 Insert : VN1604

●:庫存 In Stock    ○:非標準庫存(請確認交貨期) Non-standard Stock

# Zy 模組化內徑車刀頭 Modular Internal Head With Coolant

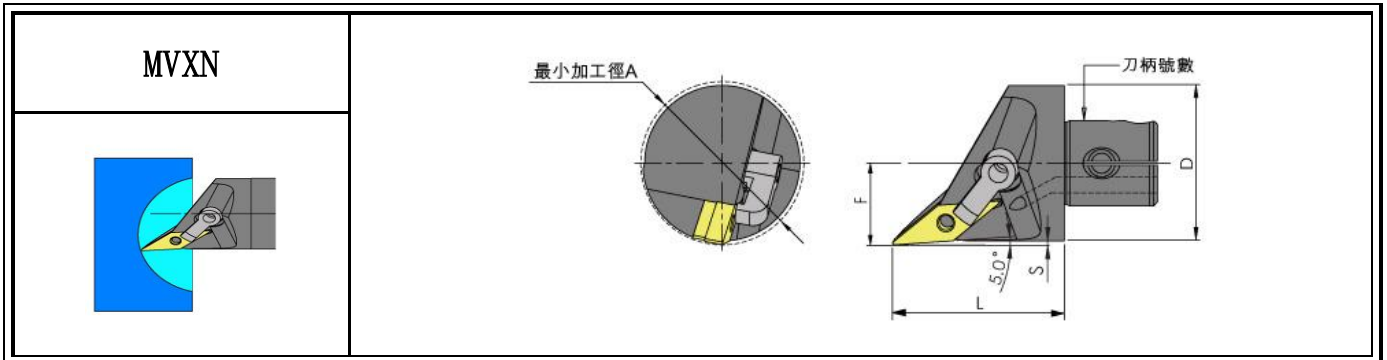

Stock	型號 Model No.	最小加工徑 A	F	D	L	S	墊片 Shim	偏心螺絲 Shim Screw	壓板 Clamp	雙頭螺絲 Clamp Screw	板手 Wrench
●	SCK3-A32-MVXNR16-40	40	23	32	35	7					
●	SCK4-A40-MVXNR16-42	42	21	40	35	1	GMV322	LCS-513	CP50-24	MS625	L2.0
●	SCK5-A50-MVXNR16-57	57	31	50	35	6					L3.0

刀片 Insert : VN1604

●:庫存 In Stock    ○:非標準庫存(請確認交貨期) Non-standard Stock



# Zy 模組化內徑車刀頭 Modular Internal Head With Coolant

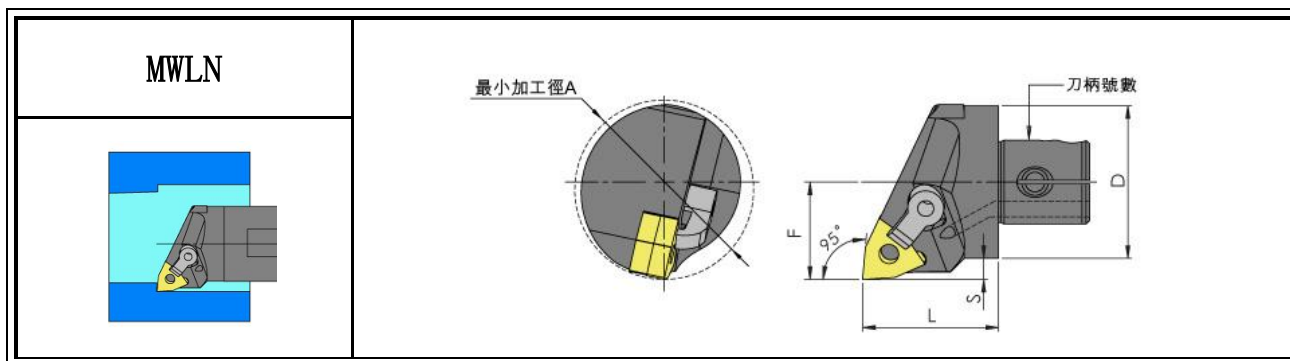

Stock	型號 Model No.	最小加工徑 A	F	D	L	S	墊片 Shim	偏心螺絲 Shim Screw	壓板 Clamp	雙頭螺絲 Shim Screw	板手 Wrench
●	SCK1-A20-MWLN R08-25	25	13	20	36	3	-	LCS-511	CP50-12	MS520	L2.5
●	SCK2-A25-MWLN R08-32	32	17	25	36	4.5	-				
●	SCK3-A32-MWLN R08-40	40	20	32	39	4	WMS432	LCS-617	CP50-22	MS625	L2.5 L3.0
●	SCK4-A40-MWLN R08-47	47	25.5	40	42	5.5					
●	SCK5-A50-MWLN R08-57	57	30.5	50	45	5.5					

刀片 Insert : WN0804

●:庫存 In Stock    ○:非標準庫存(請確認交貨期) Non-standard Stock

專利  
產品

# 阻尼吸震刀桿系列



歡迎到我們的 YouTube 上觀看實際切削影片！



## ◆特點

不再侷限於鎢鋼刀桿的 5~6 倍。

- ▶ 阻尼刀桿從 6~12 倍皆能達成。
- ▶ 沒有常常鈍刀的困擾。
- ▶ 出水孔的設計，使排屑順暢。
- ▶ 模組刀頭的設計，成本降低、選擇更多。



$$\text{伸長比} = \frac{L}{D}$$

## ◆ 模組化刀頭

便宜方便、剛性佳、穩定高。

- ▶ 兩面拘束的設計結構，堅固耐用。



# 阻尼抗震刀桿表示方式

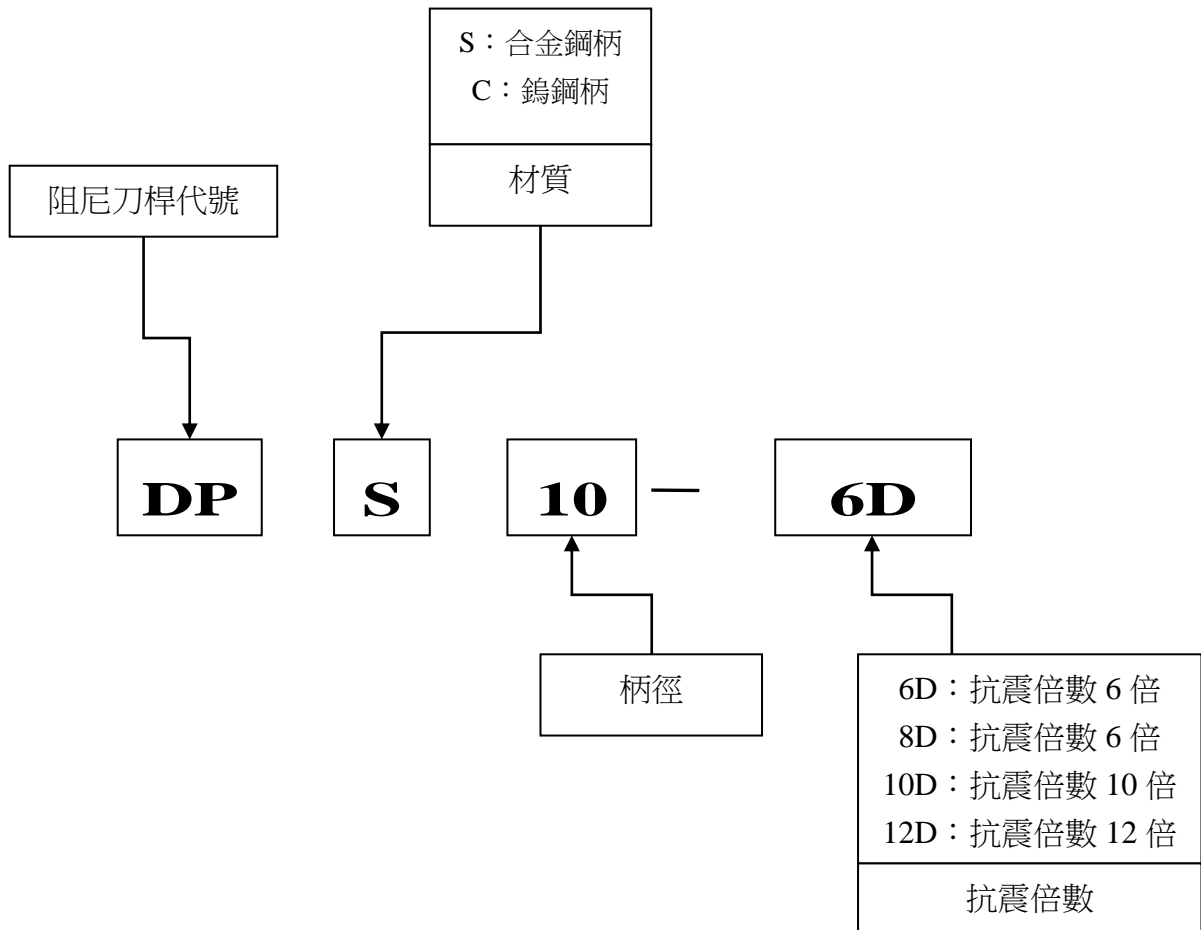

# Zy 阻尼吸震刀桿 Damping Anti-Vibration Boring Bar

DP12

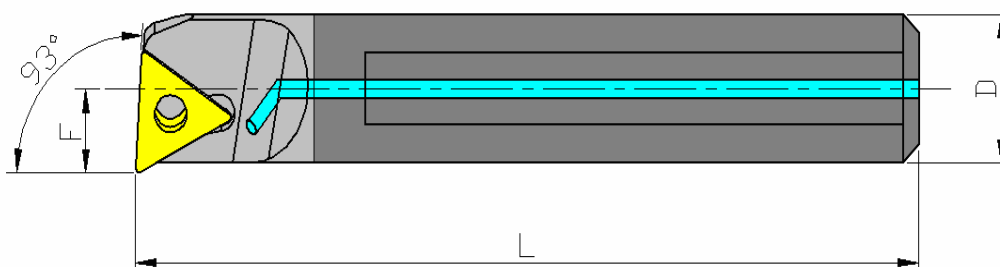

● 一體阻尼刀桿 **One-piece damping tool holder**

Stock	型號 Model No.	可搭配之刀型 Compatible tool types	D	全長 L
●	DPSE12-6D	TC、TP、DU、VC、牙刀	12	172
●	DPSE12-8D			196
●	DPCE12-10D			220
●	DPCE12-12D			244

●:庫存 In Stock    ○:非標準庫存(請確認交貨期) Non-standard Stock

※刀頭型號為示意圖，更多刀頭型號請參考 “ B7~B39 鎢鋼刀桿 ”

# Zy 阻尼吸震刀桿 Damping Anti-Vibration Boring Bar

DP14

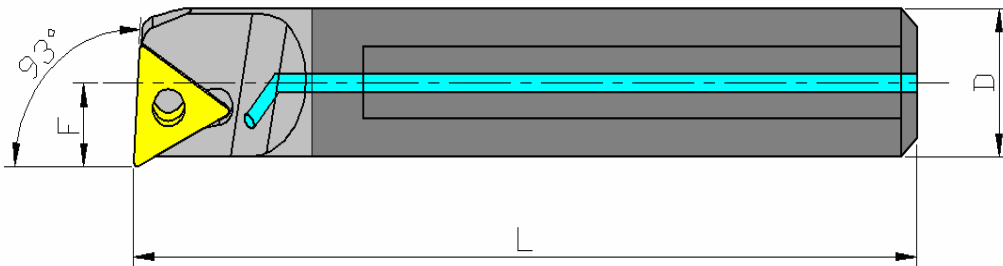

● 一體阻尼刀桿 **One-piece damping tool holder**

Stock	型號 Model No.	可搭配之刀型 Compatible tool types	D	全長 L
●	DPSE14-6D	TC、TP、DU、VC、牙刀	14	184
●	DPSE14-8D			212
●	DPCE14-10D			240
●	DPCE14-12D			268

●:庫存 In Stock    ○:非標準庫存(請確認交貨期) Non-standard Stock

※刀頭型號為示意圖，更多刀頭型號 Model No.請參考 “ B7~B39 鎢鋼刀桿 ”



# Zy 阻尼吸震刀桿 Damping Anti-Vibration Boring Bar

DP16

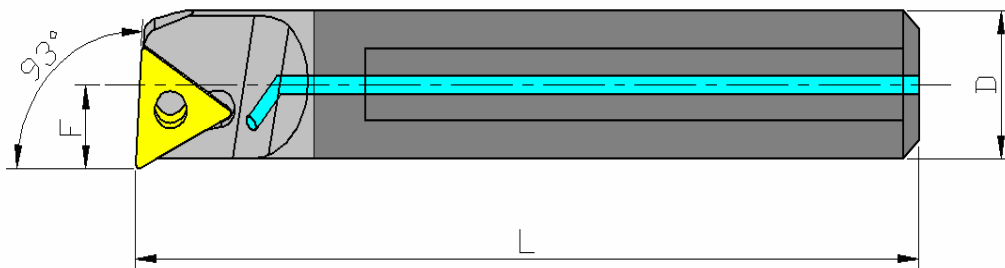

● 一體阻尼刀桿 **One-piece damping tool holder**

Stock	型號 Model No.	可搭配之刀型 Compatible tool types	D	全長 L
●	DPSE16-6D	TC、TP、DU、VC、牙刀	16	196
●	DPSE16-8D			228
●	DPCE16-10D			260
●	DPCE16-12D			292

●:庫存 In Stock    ○:非標準庫存(請確認交貨期) Non-standard Stock

※刀頭型號為示意圖，更多刀頭型號 Model No.請參考 “ B7~B39 鎢鋼刀桿 ”

# Zy 阻尼吸震刀桿 Damping Anti-Vibration Boring Bar

DP20-SCK1

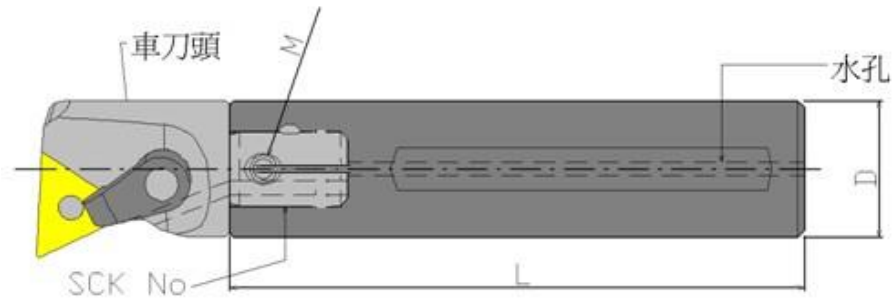

## ● 模組阻尼刀桿 Modular Chang Damping Anti-Vibration Boring Bar

Stock	型號 Model No.	組合刀頭 SCK NO	D	全長 L	 螺絲 Screw	 板手 Wrench
●	DPSSCK1-A20-200L-6D	SCK1	20	200	SETM5x8L	L2.5
●	DPSSCK1-A20-240L-8D			240		
●	DPCSK1-E20-280L-10D			280		
●	DPCSK1-E20-320L-12D			320		

●:庫存 In Stock ○:非標準庫存(請確認交貨期) Non-standard Stock

※刀頭型號為示意圖，更多刀頭型號請參考“G7~G20 模組化刀頭”



# Zy 阻尼吸震刀桿 Damping Anti-Vibration Boring Bar

DP25-SCK2

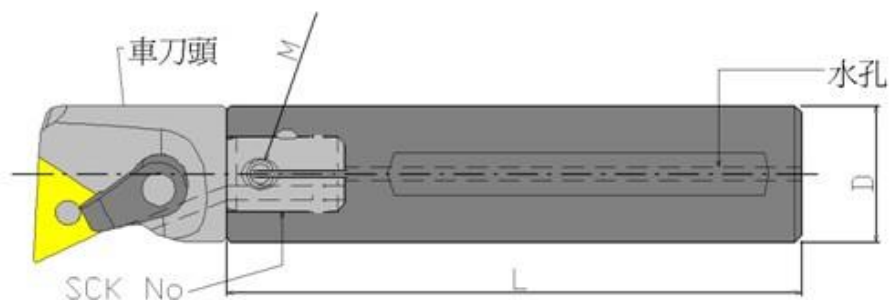

## ● 模組阻尼刀桿 Modular Chang Damping Anti-Vibration Boring Bar

Stock	型號 Model No.	組合刀頭 SCK NO	D	全長 L	 螺絲 Screw	 板手 Wrench
●	DPSSCK2-A25-225L-6D	SCK2	25	225	SETM6x8L	L3.0
●	DPSSCK2-A25-275L-8D			275		
●	DPCSK2-E25-325L-10D			325		
●	DPCSK2-E25-375L-12D			375		

●:庫存 In Stock ○:非標準庫存(請確認交貨期) Non-standard Stock

※刀頭型號為示意圖，更多刀頭型號請參考“G7~G20 模組化刀頭”

# Zy 阻尼吸震刀桿 Damping Anti-Vibration Boring Bar

DP32-SCK3

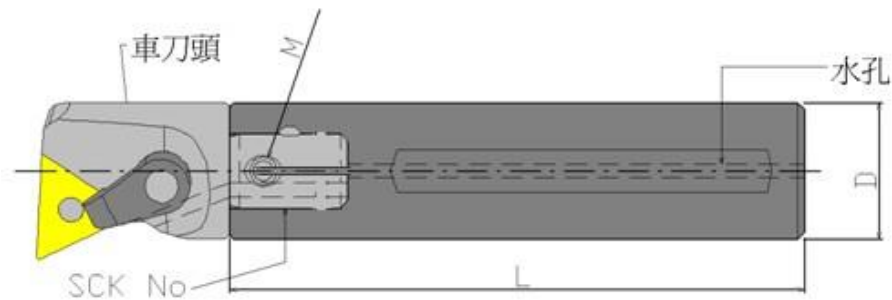

● 模組阻尼刀桿 Modular Chang Damping Anti-Vibration Boring Bar

Stock	型號 Model No.	組合刀頭 SCK NO	D	全長 L	 螺絲 Screw	 板手 Wrench
●	DPSSCK3-A32-262L-6D	SCK3	32	262	SETM6x10L	P3.0
●	DPSSCK3-A32-326L-8D			326		
●	DPCSK3-E32-390L-10D			390		
●	DPCSK3-E32-454L-12D			454		

●:庫存 In Stock    ○:非標準庫存(請確認交貨期) Non-standard Stock

※刀頭型號為示意圖，更多刀頭型號.請參考 “ G7~G20 模組化刀頭 ”

# Zy 阻尼吸震刀桿 Damping Anti-Vibration Boring Bar

DP40-SCK4

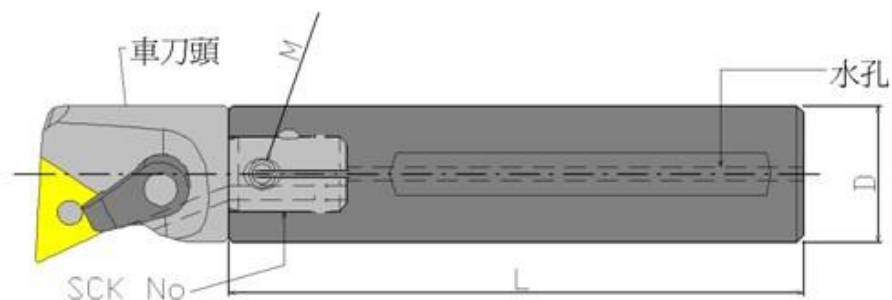

● 模組阻尼刀桿 Modular Chang Damping Anti-Vibration Boring Bar

Stock	型號 Model No.	組合刀頭 SCK NO	D	全長 L	螺絲 Screw	板手 Wrench
●	DPSSCK4-A40-330L-6D	SCK4	40	330	SETM8x16L	P4.0
●	DPSSCK4-A40-410L-8D			410		
●	DPSSCK4-A40-490L-10D			490		
●	DPSSCK4-A40-570L-12D			570		

●:庫存 In Stock    ○:非標準庫存(請確認交貨期) Non-standard Stock

※刀頭型號為示意圖，更多刀頭型號請參考 “ G7~G20 模組化刀頭 ”

# Zy 阻尼吸震刀桿 Damping Anti-Vibration Boring Bar

DP50-SCK5

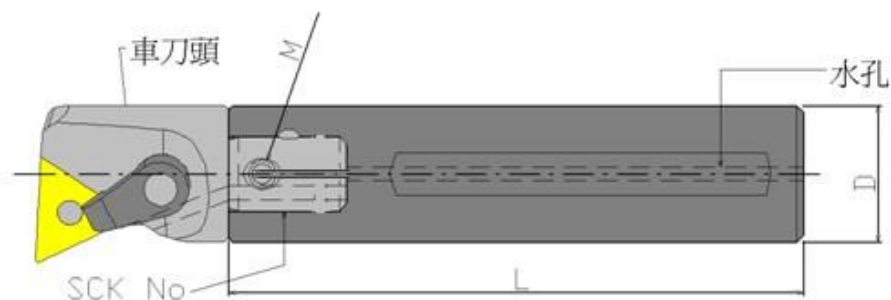

● 模組阻尼刀桿 Modular Chang Damping Anti-Vibration Boring Bar

Stock	型號 Model No.	組合刀頭 SCK NO	D	全長 L	螺絲 Screw	板手 Wrench
●	DPSSCK5-A50-375L-6D	SCK5	50	375	SETM10x16L	P5.0
●	DPSSCK5-A50-475L-8D			475		
●	DPSSCK5-A50-575L-10D			575		
●	DPSSCK5-A50-675L-12D			675		

●:庫存 In Stock    ○:非標準庫存(請確認交貨期) Non-standard Stock

※刀頭型號為示意圖，更多刀頭型號請參考“G7~G20 模組化刀頭”

# 搪刀系列



# Zy 碳化鎢搪刀組合圖 Combination of Carbide Boring Bars

## ■ 碳化鎢搪刀柄組合圖

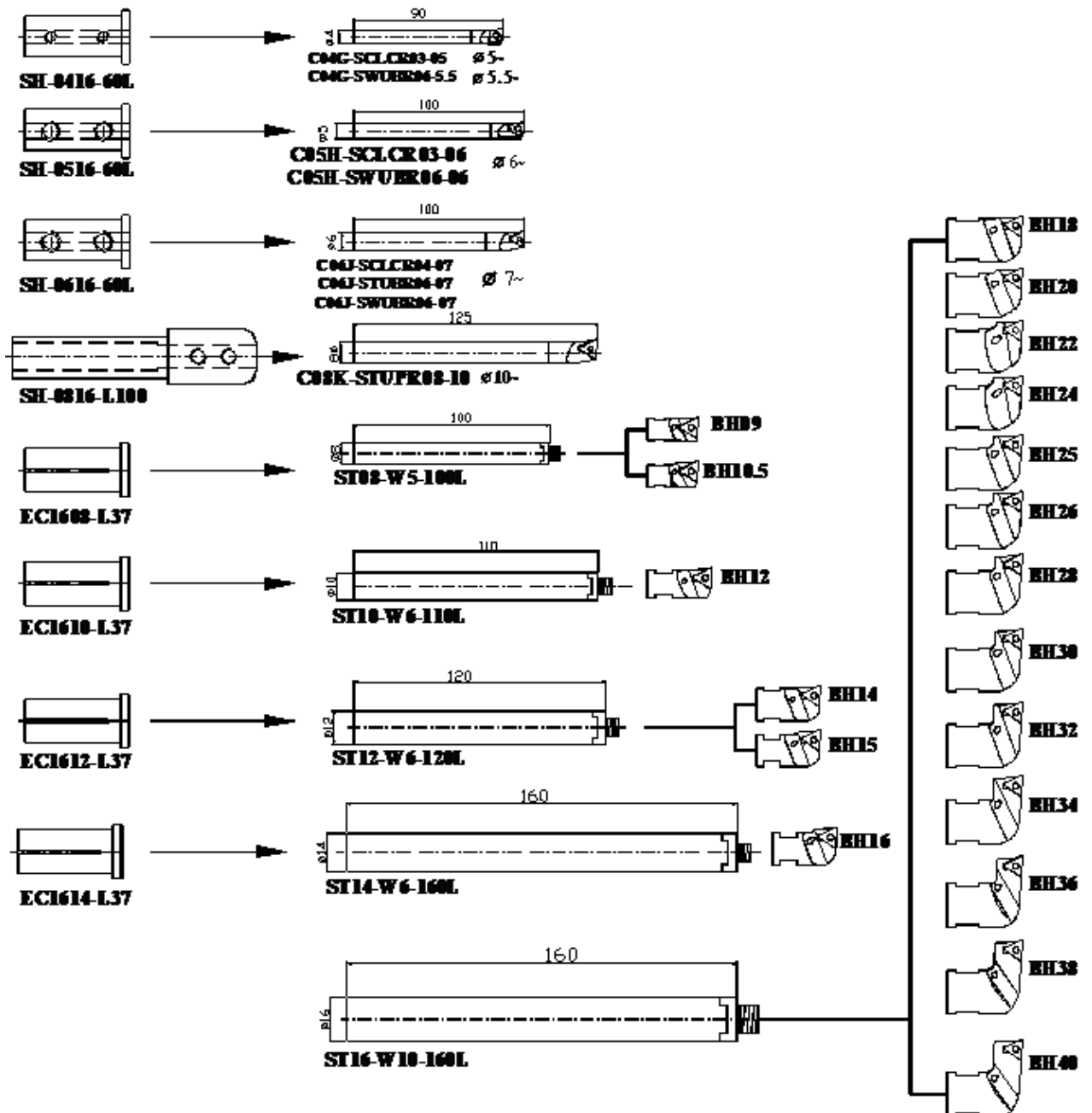

# Zy 碳化鎢鋼搪刀系列 Carbide Boring Bars

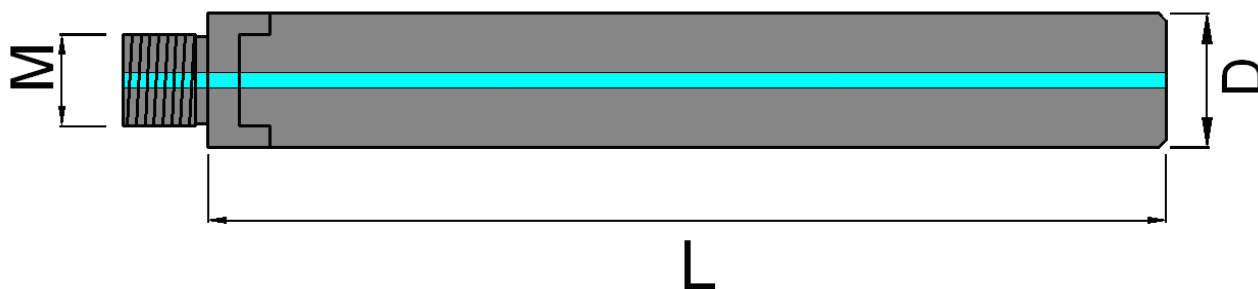

Stock	型號 Model No.	D	M	L	組合搪頭 Matched Heads
●	ST08-W5-100L	8	M5	100	BH09
●	ST10-W6-110L	10	M6	110	BH12
●	ST12-W6-120L	12	M6	120	BH14
●	ST14-W6-160L	14	M6	160	BH16
●	ST16-W10-160L	16	M10	160	BH18 BH40

●:庫存 In Stock    ○:非標準庫存(請確認交貨期) Non-standard Stock

## 組立圖

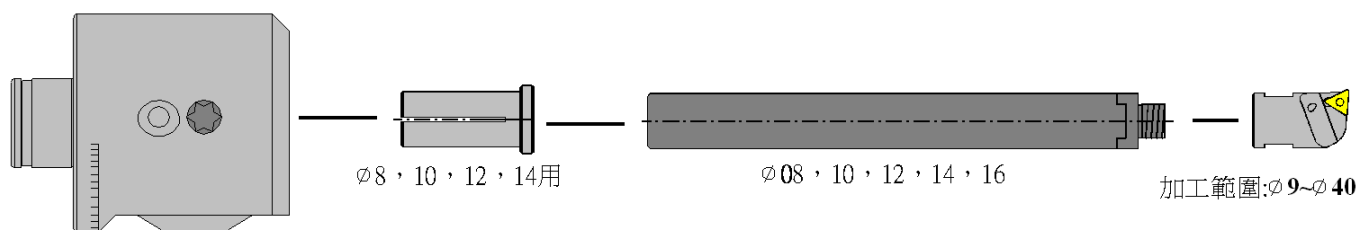

### ● 替換式搪孔套筒

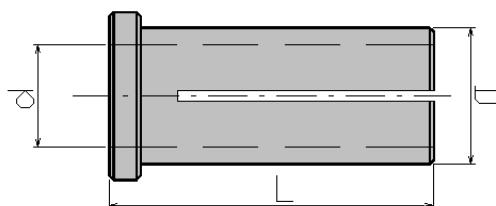

Stock	型號 Model No.	d	D	L	組合搪頭 Matched Heads
●	EC1608-L37	8	16	37	ST08-W5-100L
●	EC1610-L37	10	16	37	ST10-W6-110L
●	EC1612-L37	12	16	37	ST12-W6-120L
●	EC1614-L37	14	16	37	ST14-W6-160L

# Zy 鎖牙式搪刀頭系列 Boring Cutter Head

替換式搪孔刀頭



中央出水孔

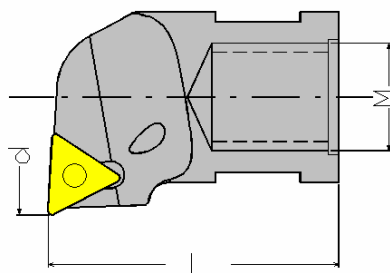

Stock	型號 Model No.	尺寸		L	M	刀片 Insert	螺絲 Screw	扳手 Wrench
		d	搪孔範圍 Range					
●	BH09	9	9~10.5	18	M5	TPGT080204L	M2. 2x5. 1x3. 1	T7
●	BH10.5	10.5	10.5~12					
●	BH12	12	12~14	23	M6			
●	BH14	14	14~15					
●	BH15	15	15~16					
●	BH16	16	16~18					
●	BH18	18	18~20	27	M10			
●	BH20	20	20~22					
●	BH22	22	22~24					
●	BH24	24	24~25					
●	BH25	25	25~26					
●	BH26	26	26~28					
○	BH28	28	28~30					
○	BH30	30	30~32					
○	BH32	32	32~34					
○	BH34	34	34~36					
○	BH36	36	36~38					
○	BH38	38	38~40					
○	BH40	40	40~42					

●:庫存 In Stock    ○:非標準庫存(請確認交貨期) Non-standard Stock



# Zy 碳化鎢鋼搪刀系列 Carbide Boring Bar

碳化鎢小徑搪刀 Micro Internal Boring Bars

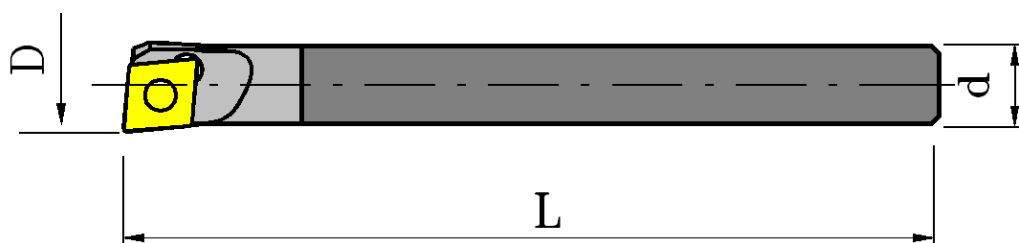

Stock	型號 Model No.	d	L	最小搪孔徑 D Min Boring D	刀片 Insert	 螺絲 Screw
●	C04G-SWUBR06-055	4	90	5.5	WB06	M2x3.7x2.6-60
●	C05H-SWUBR06-06	5	100	6	WB06	M2x3.7x2.6-60
●	C06J-SWUBR06-07	6	110	7	WB06	M2x5.0x2.6
●	C04G-SCLCR03-05	4	90	5.6	CC03	M1.8x4.0x2.5-54
●	C05H-SCLCR03-06	5	100	6	CC03	M1.8x4.0x2.5-54
●	C06J-SCLCR04-07	6	110	7	CC04	M2.2x5.1x3.1
●	C06J-STUBR06-07	6	110	7	TB06	M2x5.0x2.6
●	C08K-STUPR08-10	8	125	10	TP08	M2.2x5.1x3.1

●:庫存 In Stock    ○:非標準庫存(請確認交貨期) Non-standard Stock

# Zy 搪刀系列 Boring Adapters

## 搪孔組合圖

MODULAR BORING SYSTEMS

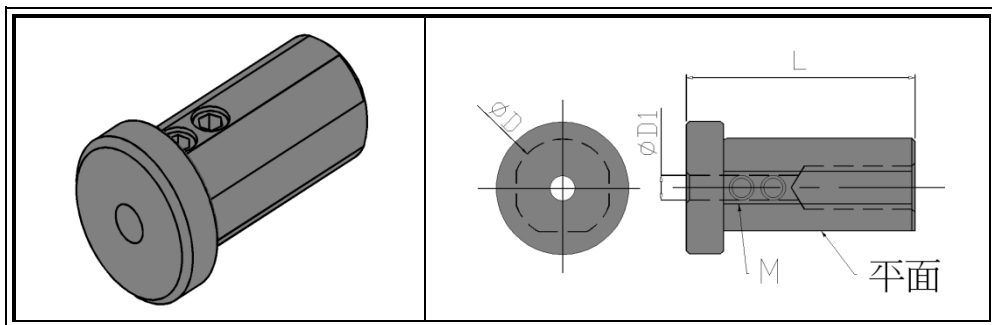
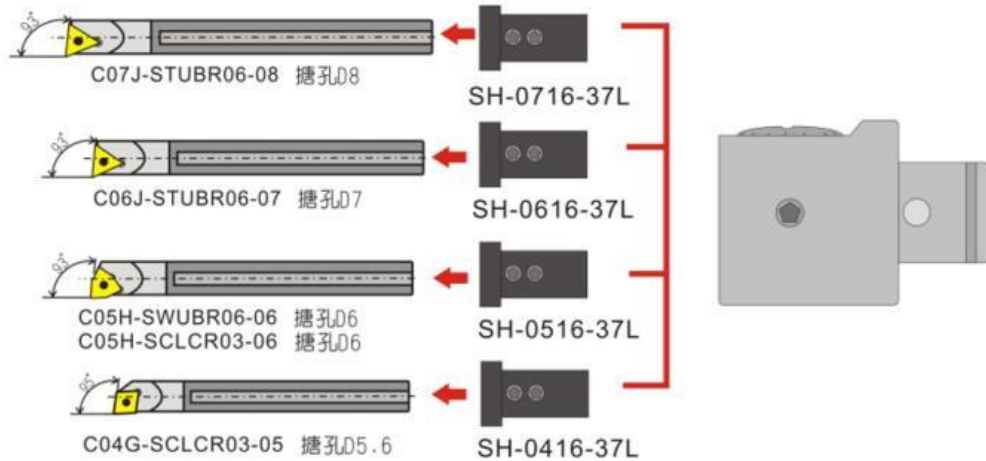

Stock	型號 Model No.	D	D1	H	L	螺絲 Screw	板手 Wrench
●	SH-0416-37	16	4	15	37	SETM4x4L	P2.0
●	SH-0516-37	16	5	15	37	SETM5x5L	P2.5
●	SH-0616-37	16	6	15	37	SETM6x4L	P3.0
●	SH-0716-37	16	7	15	37	SETM6x4L	P3.0

●:庫存 In Stock    ○:非標準庫存(請確認交貨期) Non-standard Stock

# Zy 搪孔刀架系列 Boring Cutter

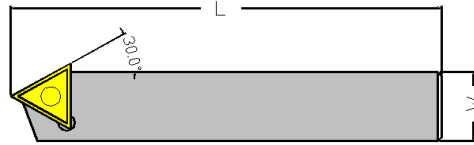

Stock	型號 Model No.	W	L	螺絲 Screw	板手 Wrench	刀片 Insert
○	SBS-308-TP07	8	50	M2. 2x5. 1x3. 1	T7	TP0701
○	SBS-310-TP09	10	60	M3x7. 8x4. 1	T9	TP0902
●	SBS-313-TP11	13	80	M3x7. 8x4. 10	T9	TP1103
○	SBS-316-TP11	16	100	M3x7. 8x4. 1	T9	TP1103
○	SBS-319-TP16	19	125	M4x8. 8x5. 4	T15	TP16T3
○	SBS-325-TP16	25	150	M4x8. 8x5. 4	T15	TP16T3

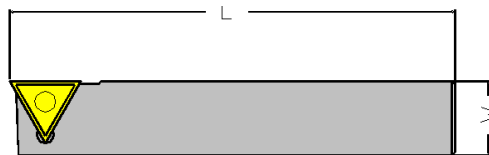

Stock	型號 Model No.	W	L	螺絲 Screw	板手 Wrench	刀片 Insert
○	SBS-108-TP07	8	50	M2. 2x5. 1x3. 1	T7	TP0701
○	SBS-110-TP09	10	60	M2. 5x6. 0x3. 6	T8	TP0902
●	SBS-113-TP11	13	80	M3x7. 8x4. 1	T9	TP1103
○	SBS-116-TP11	16	100	M3x7. 8x4. 1	T9	TP1103
○	SBS-116-TP16	16	100	M4x8. 8x5. 4	T15	TP16T3
○	SBS-119-TP16	19	125	M4x8. 8x5. 4	T15	TP16T3
○	SBS-125-TP16	25	150	M4x8. 8x5. 4	T15	TP16T3

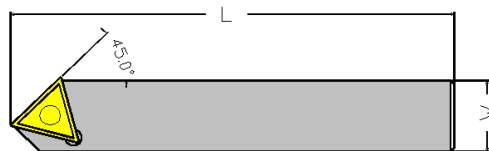

Stock	型號 Model No.	W	L	螺絲 Clamp Screw	板手 Wrench	刀片 Insert
○	SBS-408-TP07	08	50	M2. 2x5. 1x3. 1	T7	TP0701
○	SBS-410-TP09	10	60	M2. 5x6. 0x3. 6	T8	TP0902
●	SBS-413-TP11	13	80	M3x7. 8x4. 1	T9	TP1103
●	SBS-416-TP11	16	100	M3x7. 8x4. 1	T9	TP1103
○	SBS-419-TP16	19	125	M4x8. 8x5. 4	T15	TP16T3
○	SBS-425-TP16	25	150	M4x8. 8x5. 4	T15	TP16T3

合金銑刀



鎢鋼銑刀



鎖牙式銑刀



# 銑刀系列

# 世界首創，獨家開發！



90°的AP1135刀架

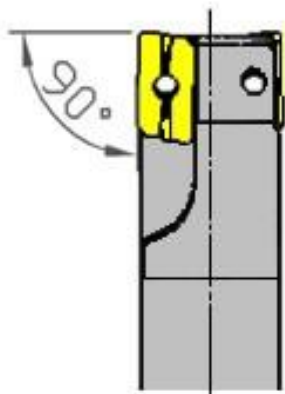
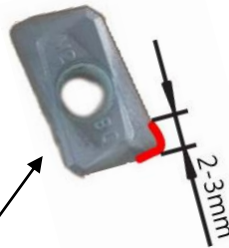

使用習慣刀面2~3mm



開發具有斜度功能的刀架



使用到整個側邊刀刃

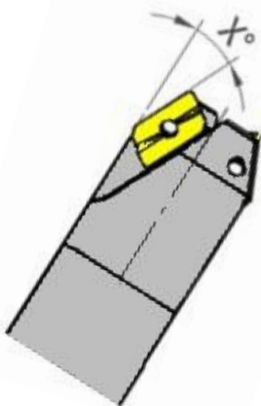

1 多種角度可以選擇，讓你選擇最適合的角度。



2 不僅可以銑端面，還可以倒角。



3 增加刀片的使用效益。

# 鎖牙式銑刀表示方法

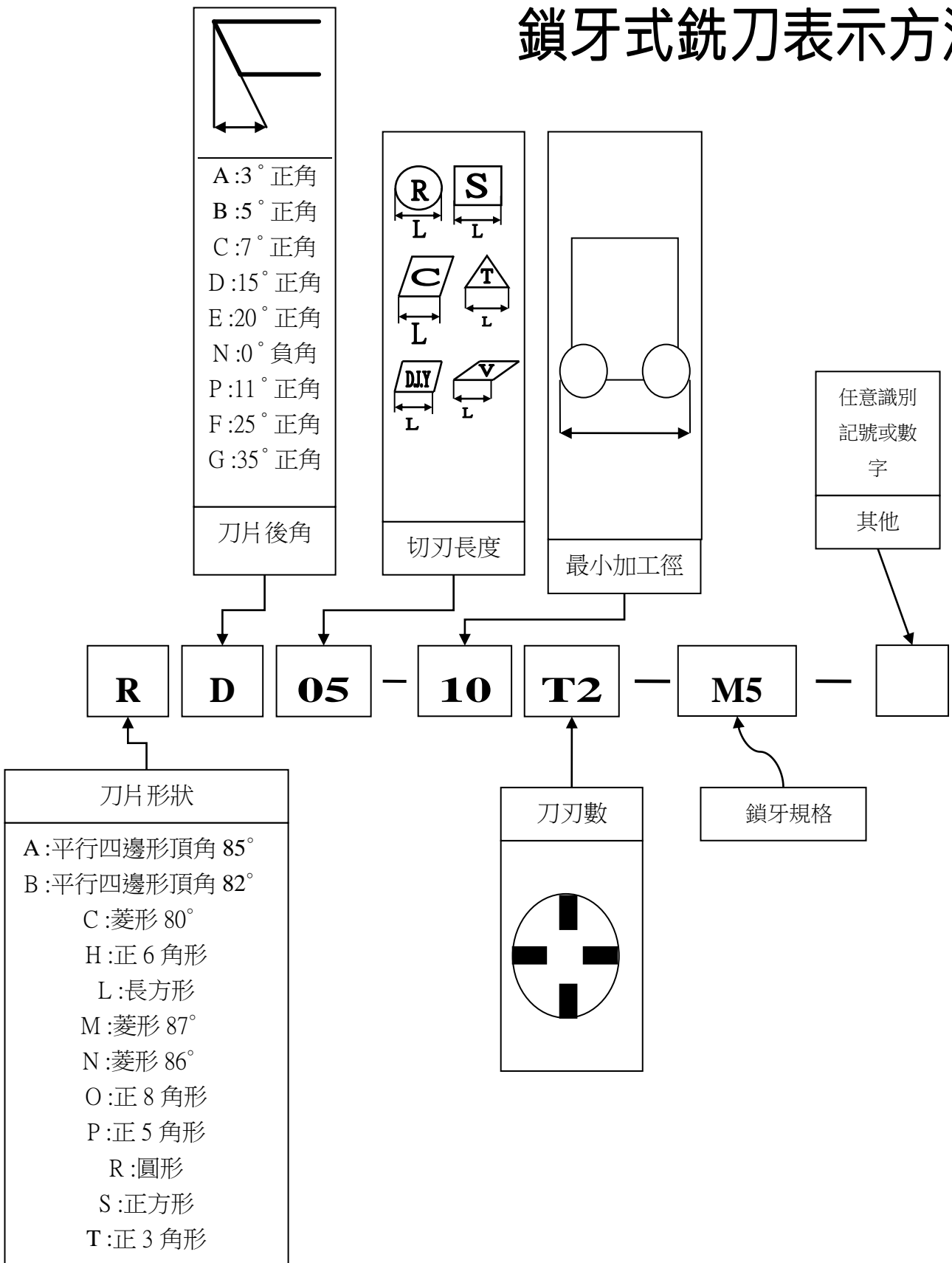

# 一體式銑刀表示方法

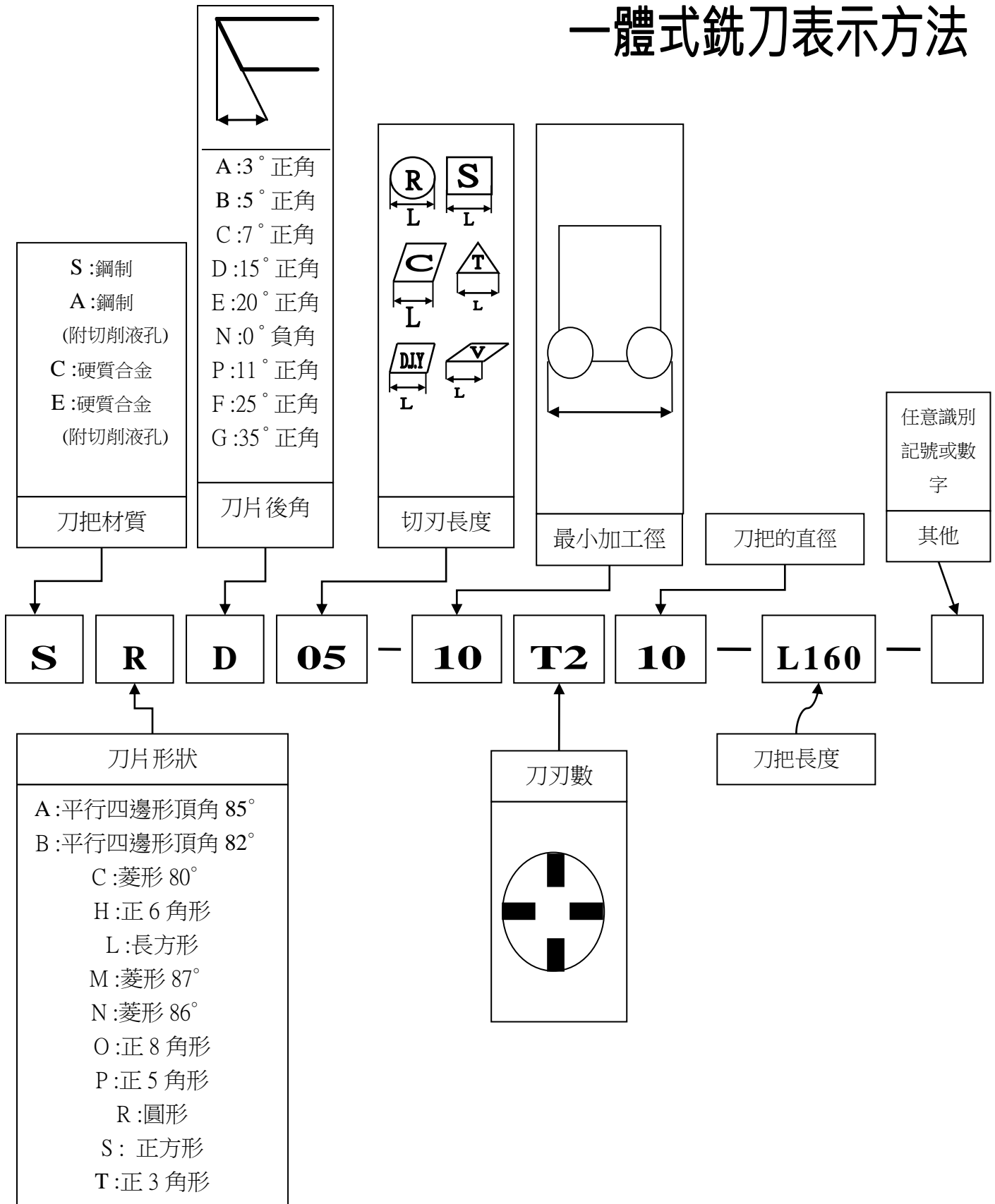

# Zy 碳化鎢鋼水孔銑刀桿 Carbide Arbors with coolant

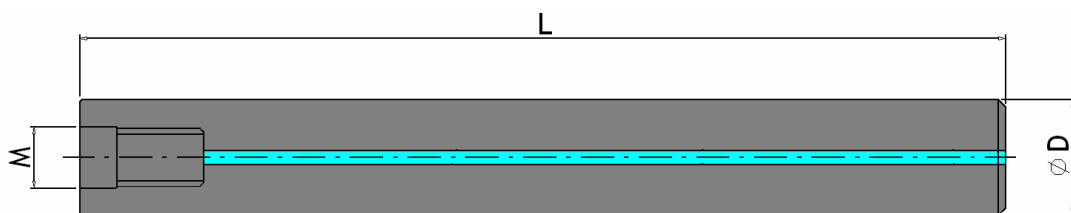

Stock	型號 Model No.	D	L	M	適用刀徑 Suitable
●	HE10-100L-M5	10	100	5	10 11
●	HE10-125L-M5	10	125	5	
●	HE10-150L-M5	10	150	5	
●	HE12-100L-M6	12	100	6	12 13
●	HE12-125L-M6	12	125	6	
●	HE12-150L-M6	12	150	6	
●	HE16-100L-M8	16	100	8	16 17
●	HE16-150L-M8	16	150	8	
●	HE16-200L-M8	16	200	8	
●	HE20-150L-M10	20	150	10	
●	HE20-200L-M10	20	200	10	
●	HE25-150L-M12	25	150	12	25 26
●	HE25-200L-M12	25	200	12	
●	HE25-250L-M12	25	250	12	

●:庫存 In Stock    ○:非標準庫存(請確認交貨期) Non-standard Stock

# 高硬度水孔銑刀桿 High-Hardness Steel Arbors with coolant

Stock	型號 Model No.	D	L	M	適用刀徑 Suitable
●	YE10-60LA2-M5	10	60	5	10 11
●	YE1210-71LA6-M5	12	71	5	12 13
●	YE1612-90LA2-M6	16	90	6	16 17
●	YE1615-100LA2.5-M8	16	100	8	16 17
●	YE2015-120LA2.5-M8	20	120	8	20 21
●	YE20-101LA2.5-M10	20	101	10	20 21
●	YE25-101L-M12	25	101	12	25 26

●:庫存 In Stock    ○:非標準庫存(請確認交貨期) Non-standard Stock



# Zy 合金鋼鎖牙式銑刀頭系列 End Mill Head

RD 刀片 Insert

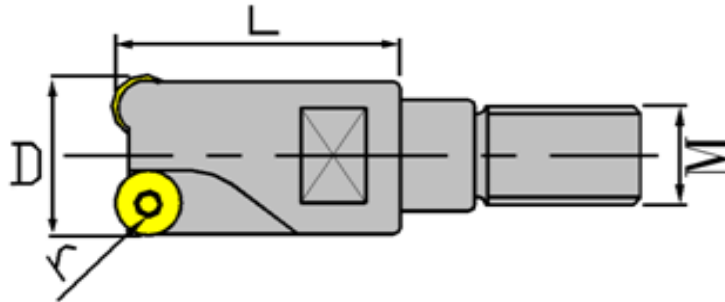

Stock	型號 Model No.	D	L	M	r	刃數 Teeth	壓板 Clamp	螺絲 Screw	板手 Wrench	刀片 Insert
●	RD05-10T2-M5	10	16	5	2.5	2	-	M2.5x6.0x3.6	T6	RD0501
●	RD05-11T2-M5	11	16	5	2.5	2				
●	RD05-12T3-M6	12	18	6	2.5	3				
●	RD05-13T2-M6	13	19	6	2.5	2				
●	RD05-13T3-M6	13	18	6	2.5	3				
●	RD07-17T3-M8	17	20	8	3.5	3	-	M2.5x6.0x3.6	T8	RD0702
●	RD07-20T3-M10	20	25	10	3.5	3				
●	RD07-21T3-M10	21	25	10	3.5	3				
●	RD07-26T4-M12	26	25	12	3.5	4				
○	RD07-26T5-M12	26	25	12	3.5	5				
○	RD10-21T3-M10	21	30	10	5	3	-	M3.5-7.6-5.1-60	T15	RD1003
●	RD10-25T3-M12	25	29	12	5	3				
●	RD10-26T3-M12	26	29	12	5	3				
●	RD10-32T4-M16	32	35	16	5	4				
●	RD10-35T4-M16	35	35	16	5	4				
●	RD10T3-32T3-M16	32	35	16	5	3	YR05	M4.0x8.8-5.4	T15	RD10T3
●	RD10T3-35T3-M16	35	35	16	5	3				
●	RD1204-32T2-M16	32	35	16	16	2	-	M4.0x8.8-5.4	T15	RD1204

●:庫存 In Stock    ○:非標準庫存(請確認交貨期) Non-standard Stock

# Zy 碳化鎢鋼銑刀 Carbide End Mill

RD 刀片 Insert

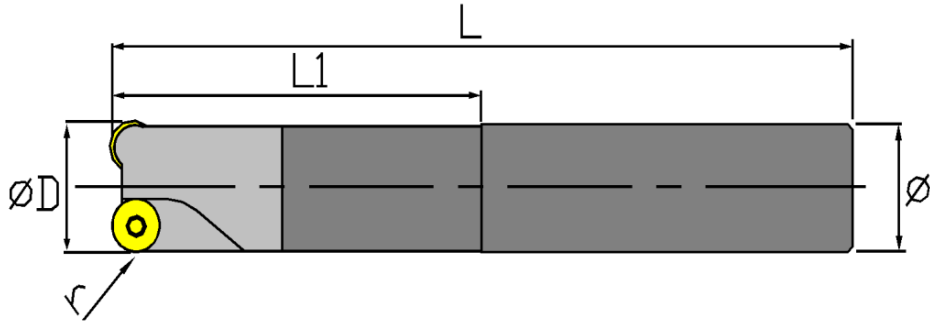

Stock	型號 Model No.	D	d	L	L1	r	刃數 Teeth	螺絲 Screw	扳手 Wrench	刀片 Insert
●	CRD05-10T210-85L	10	10	85	40	2.5	2	M2.5x6.0x3.6	T6	RD0501
○	CRD05-11T210-110L	11	10	110	0	2.5	2			
●	CRD05-12T212-95L	12	12	95	50	2.5	2			
●	CRD05-12T312-95L	12	12	95	50	2.5	3			
●	CRD05-13T312-95L	13	12	95	50	2.5	3			
●	CRD05-13T212-125L	13	12	125	0	2.5	2			
●	CRD05-13T312-125L	13	12	125	0	2.5	3			
○	CRD07-17T216-150L	17	16	150	0	3.5	2	M2.5x6.0x3.6	T8	RD0702
○	CRD07-17T216-200L	17	16	200	0	3.5	2			
○	CRD07-21T320-150L	21	20	150	0	3.5	3			
○	CRD07-21T320-200L	21	20	200	0	3.5	3			
○	CRD07-26T425-150L	26	25	150	0	3.5	4			
○	CRD07-26T425-250L	26	25	250	0	3.5	4			
○	CRD10-21T220-200L	21	20	200	0	5	2	M3.5x7.6x5.1	T15	RD1003
○	CRD10-26T325-250L	26	25	250	0	5	3			

●:庫存 In Stock    ○:非標準庫存(請確認交貨期) Non-standard Stock

# Zy 碳化合金鋼銑刀 Carbide End Mill

RD 刀片 Insert

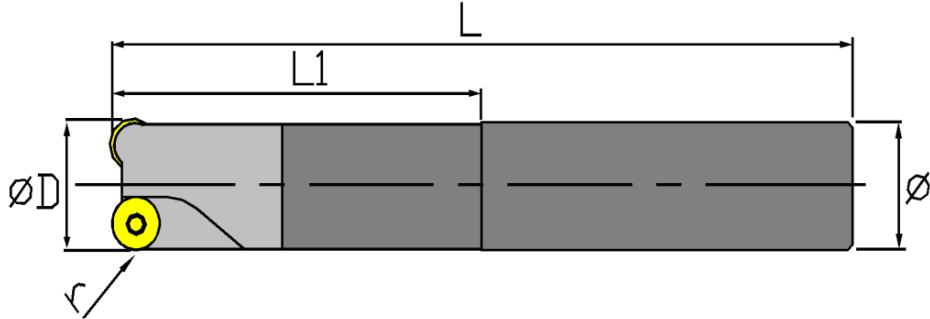



Stock	型號 Model No.	D	d	L	L1	r	刃數 Teeth	螺絲 Screw	板手 Wrench	刀片 Insert
●	SRD05-10T210-80L	10	10	80	0	2.5	2	M2.5x6.0x3.6	T6	RD0501
●	SRD05-11T210-100L	11	10	100	0	2.5	2			
●	SRD05-12T212-80L	12	12	80	0	2.5	2			
●	SRD05-12T312-80L	12	12	80	0	2.5	3			
●	SRD05-13T312-80L	13	12	80	0	2.5	3			
○	SRD05-13T312-100L	13	12	100	0	2.5	3			
○	SRD05-13T312-120L	13	12	120	0	2.5	3			
●	SRD07-16T216-150L	16	16	150	0	3.5	2	M2.5x6.0x3.6	T8	RD0702
●	SRD07-17T216-150L	17	16	150	0	3.5	2			
●	SRD07-20T320-150L	20	20	150	0	3.5	3			
●	SRD07-21T320-150L	21	20	150	0	3.5	3			
●	SRD07-26T425-150L	26	25	150	0	3.5	4			
○	SRD10-21T220-150L	21	20	150	0	5	2	M3.5x7.6x5.1	T15	RD1003
●	SRD10-26T325-150L	26	25	150	0	5	3			

●:庫存 In Stock    ○:非標準庫存(請確認交貨期) Non-standard Stock

# Zy 合金鋼銑刀盤 Milling Cutter

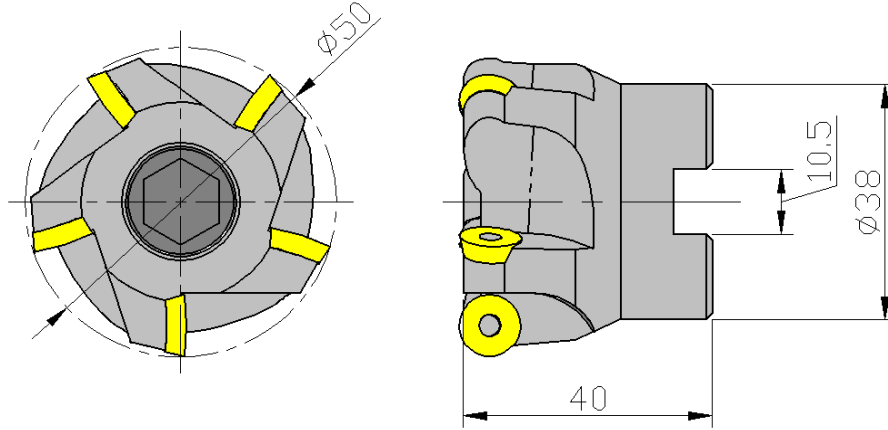
RD 刀片 Insert

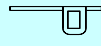

Stock	型號 Model No.	刃數 Teeth	 螺絲 Screw	 板手 Wrench	刀片 Insert
●	RD1003T5-D50-FMA22	5	M3. 5x7. 6x5. 1-60	T15	RD1003

●:庫存 In Stock    ○:非標準庫存(請確認交貨期) Non-standard Stock

# Zy 合金鋼鎖牙式銑刀頭系列 End Mill Head

AP 刀片 Insert

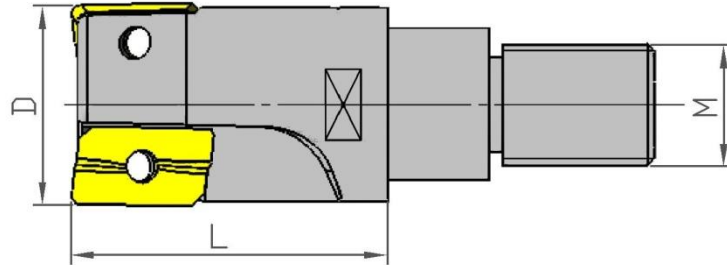

Stock	型號 Model No.	D	L	M	刃數 Teeth	螺絲 Screw	板手 Wrench	刀片 Insert
●	AP1135-16T2-M8	16	16	8	2	M2.5x6.0x3.6	T8	APMT1135
●	AP1135-17T2-M8	17	16	8	2			
●	AP1135-20T3-M10	20	25	10	3			
●	AP1135-21T3-M10	21	25	10	3			
●	AP1135-25T4-M12	25	25	12	4			
●	AP1135-26T4-M12	26	25	12	4			
●	AP1135-32T4-M16	32	35	16	4			
●	AP1135-32T5-M16	32	35	16	5			
●	AP1135-33T5-M16	33	35	16	5			
●	AP1135-35T5-M16	35	35	16	5			
○	AP1604-26T2-M12	26	35	12	2	M4.0x8.8-5.4	T15	APMT1604
●	AP1604-32T2-M16	32	35	16	2			
●	AP1604-32T3-M16	32	35	16	3			
●	AP1604-33T3-M16	33	35	16	3			
●	AP1604-35T3-M16	35	35	16	3			

●:庫存 In Stock    ○:非標準庫存(請確認交貨期) Non-standard Stock

# Zy 合金鋼銑刀系列 Alloy Steel End Mill

AP 刀片 Insert

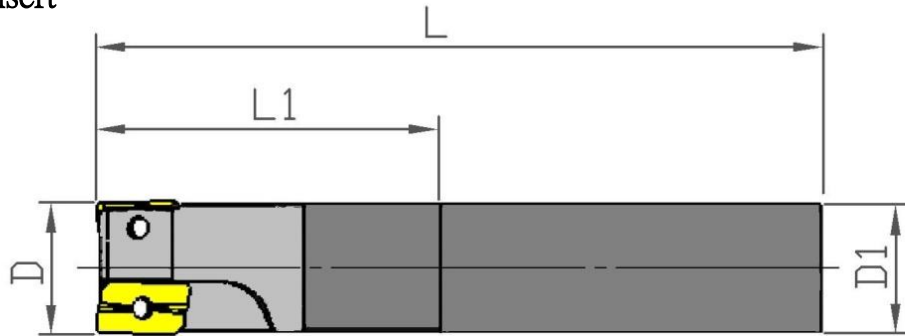

Stock	型號 Model No.	D	D1	L	L1	刃數 Teeth	螺絲 Screw	板手 Wrench	刀片 Insert
●	SAP1135-14T216-150L/25	14	16	150	25	2	M2. 5x6. 0x3. 6	T8	APMT1135
●	SAP1135-16T216-150/28	16	16	150	28	2			
●	SAP1135-17T216-150L	17	16	150	0	2			
●	SAP1135-18T220-150L/28	18	20	150	28	2			
●	SAP1135-20T220-150L/28	20	20	150	28	2			
●	SAP1135-20T220-200L/28	20	20	200	28	2			
●	SAP1135-20T320-150L/28	20	20	150	28	3			
●	SAP1135-20T320-200L/28	20	20	200	28	3			
●	SAP1135-21T220-150L	21	20	150	0	2			
●	SAP1135-21T220-200L	21	20	200	0	2			
●	SAP1135-21T320-150L	21	20	150	0	3			
●	SAP1135-21T320-200L	21	20	200	0	3			
●	SAP1135-25T325-150L/35	25	25	150	35	3			
●	SAP1135-25T325-200L/35	25	25	200	35	3			
●	SAP1135-25T425-150L/35	25	25	150	35	4			
●	SAP1135-25T425-200L/35	25	25	200	35	4			
●	SAP1135-26T325-150L	26	25	150	0	3			
●	SAP1135-26T325-200L	26	25	200	0	3			
●	SAP1135-26T425-150L	26	25	150	0	4			
●	SAP1135-26T425-200L	26	25	200	0	4			
●	SAP1135-32T432-150L/35	32	32	150	35	4			
●	SAP1135-32T432-200L/35	32	32	200	35	4			
●	SAP1135-33T432-150L	33	32	150	0	4			
●	SAP1135-33T432-200L	33	32	200	0	4			

●:庫存 In Stock    ○:非標準庫存(請確認交貨期) Non-standard Stock

# Zy 合金鋼銑刀系列 Alloy Steel End Mill

AP 刀片 Insert

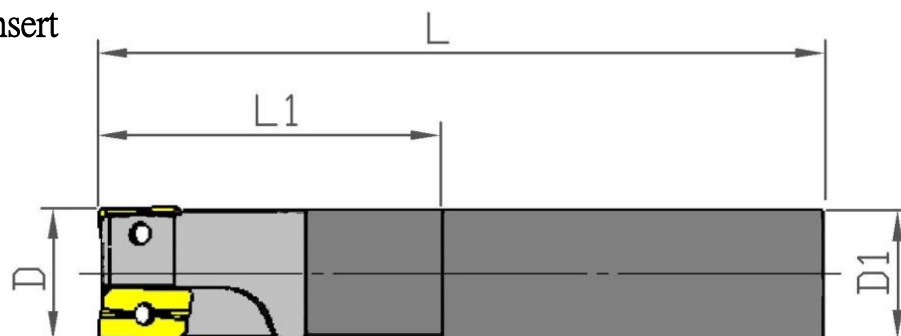

Stock	型號 Model No.	D	D1	L	刃數 Teeth	螺絲 Screw	扳手 Wrench	刀片 Insert
●	SAP1604-25T225-150L	25	25	150	2	M2.5x6.0x3.6	T8	APMT1604
●	SAP1604-26T225-150L	26	25	150	2			
●	SAP1135-32T232-150L	32	32	150	2			
●	SAP1135-32T332-150L	32	32	150	3			
●	SAP1135-33T332-150L	33	32	150	3			
●	SAP1135-35T332-200L	35	32	150	3			

●:庫存 In Stock    ○:非標準庫存(請確認交貨期) Non-standard Stock

# Zy 斜度銑刀系列 Tapered End Mill

AP 刀片 Insert

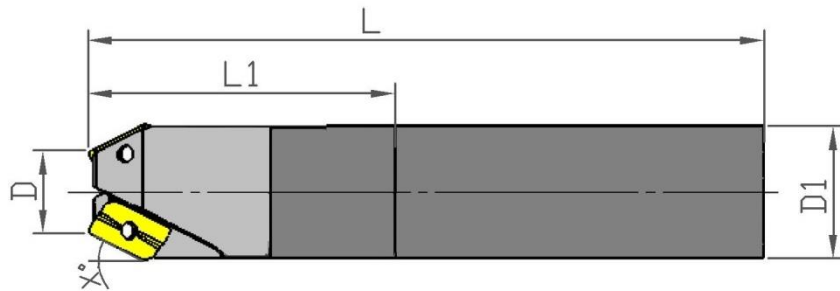

Stock	型號 Model No.	D	D1	L	L1	角度 x° Angle	刃數 Teeth	螺絲 Screw	板手 Wrench	刀片 Insert
●	AP1135-14T220A5	14	20	150	32	5°	2	M2. 5x6. 0x3. 6	T8	APMT1135
●	AP1135-14T220A15	14	20	150	32	15°	2			
●	AP1135-14T220A30	14	20	150	32	30°	2			
●	AP1135-14T220A45	14	20	150	32	45°	2			
●	AP1135-14T220A60	14	20	150	32	60°	2			

●:庫存 In Stock    ○:非標準庫存(請確認交貨期) Non-standard Stock



# Zy 合金鋼銑刀盤 Milling Cutter

AP 刀片 Insert

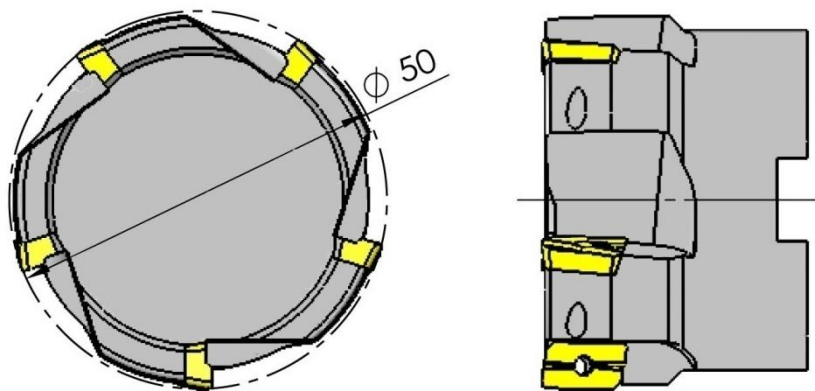

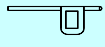
Stock	型號 Model No.	刃數 Teeth	 螺絲 Screw	 板手 Wrench	刀片 Insert
●	APMT1103T5-D50-FMA22	5	M2.5x6.0x3.6	T8	APMT1135

●:庫存 In Stock    ○:非標準庫存(請確認交貨期) Non-standard Stock

# Zy 合金鋼鎖牙式銑刀頭系列 End Mill Head

## AX 刀片 Insert

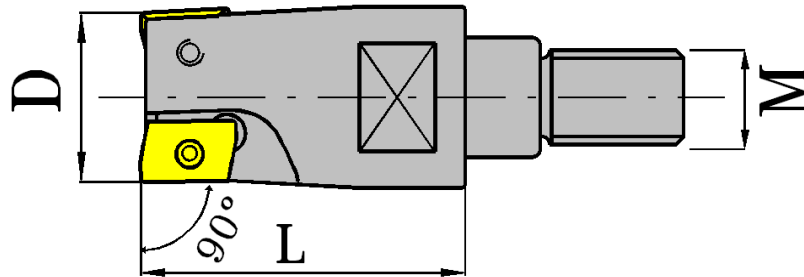

Stock	型號 Model No.	D	L	M	刃數 Teeth	螺絲 Screw	扳手 Wrench	刀片 Insert
○	90AX06-11T2-M5	11	18	5	2	M1.8x4.0x2.5-54	T6	AXMT06
●	90AX06-12T3-M6	12	18	6	3			
●	90AX06-13T3-M6	13	18	6	3			
○	90AX06-17T4-M8	17	23	8	4			
○	90AX06-21T4-M10	21	30	10	4			
○	90AX09-17T2-M8	17	23	8	2	M2.5x6.0x3.6	T8	AXMT09
○	90AX09-21T3-M10	21	30	10	3			

●:庫存 In Stock    ○:非標準庫存(請確認交貨期) Non-standard Stock

## CC 刀片 Insert

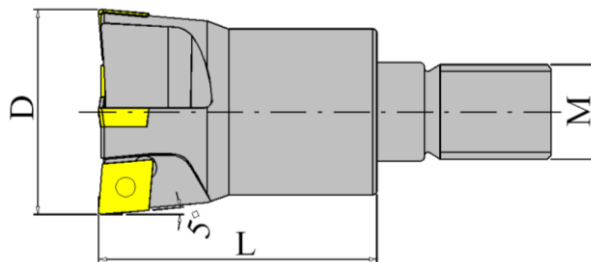

Stock	型號 Model No.	D	L	M	刃數 Teeth	螺絲 Screw	扳手 Wrench	刀片 Insert
○	CC06-21T3-M10	21	31	10	3	M2.5-6.0-3.5-60	T8	CCMT0602
●	CC06-26T4-M12	26	35	12	4			

●:庫存 In Stock    ○:非標準庫存(請確認交貨期) Non-standard Stock

# Zy 碳化鎢鋼銑刀 Carbide End Mill

AX 刀片 Insert

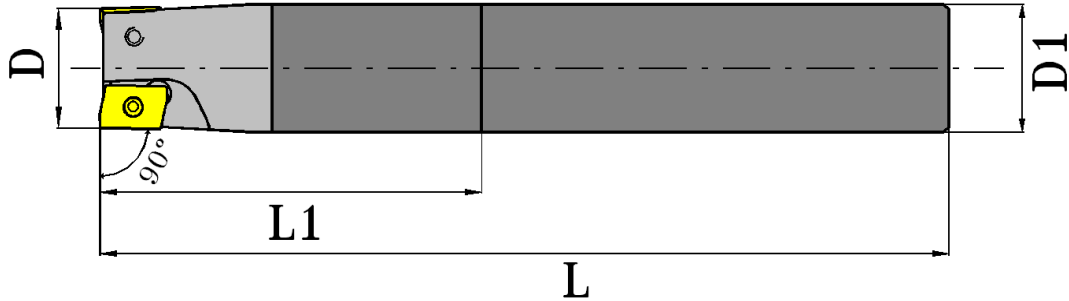

Stock	型號 Model No.	D	D1	L	刃數 Teeth	螺絲 Screw	扳手 Wrench	刀片 Insert
●	CAX06-10T210-80L	10	10	85	2	M1. 8x4. 0x2. 5-54	T6	AXMT0602
○	CAX06-12T212-95L	12	12	95	2			
○	CAX06-12T312-95L	12	12	95	3			

●:庫存 In Stock    ○:非標準庫存(請確認交貨期) Non-standard Stock

# 合金鋼銑刀系列 Alloy Steel End Mill

Stock	型號 Model No.	D	D1	L	刃數 Teeth	螺絲 Screw	扳手 Wrench	刀片 Insert
●	SAX06-10T210-80L	10	10	80	2	M1. 8x4. 0x2. 5-54	T6	AXMT0602
○	SAX06-12T212-80L	12	12	90	2			
●	SAX06-12T312-80L	12	12	80	3			

●:庫存 In Stock    ○:非標準庫存(請確認交貨期) Non-standard Stock

# 最任性的快鑽



# C型快鑽

成本更省 效率不減

採流通性高的 **C型** 刀片

不綁刀片，  
可使用各廠牌比較有特色的刀片。

整合刀片

減少刀片的使用種類，利於刀片管理。

使用100°角

即第3、4角，可當快鑽內刃用。



加工多樣化

特別強調! **可鑽! 可車! 可銑!**  
複合式加工的能力。

1.直孔 2.入口斜向鑽孔 3.半孔加工 4.魚眼加工 5.十字交叉孔加工 6.凸孔 7.凹孔 8.內徑加工 9.外徑加工 10.端面加工

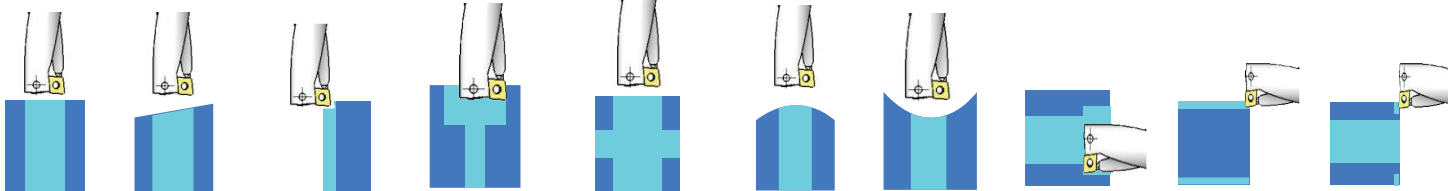

# C型快鑽表示方式

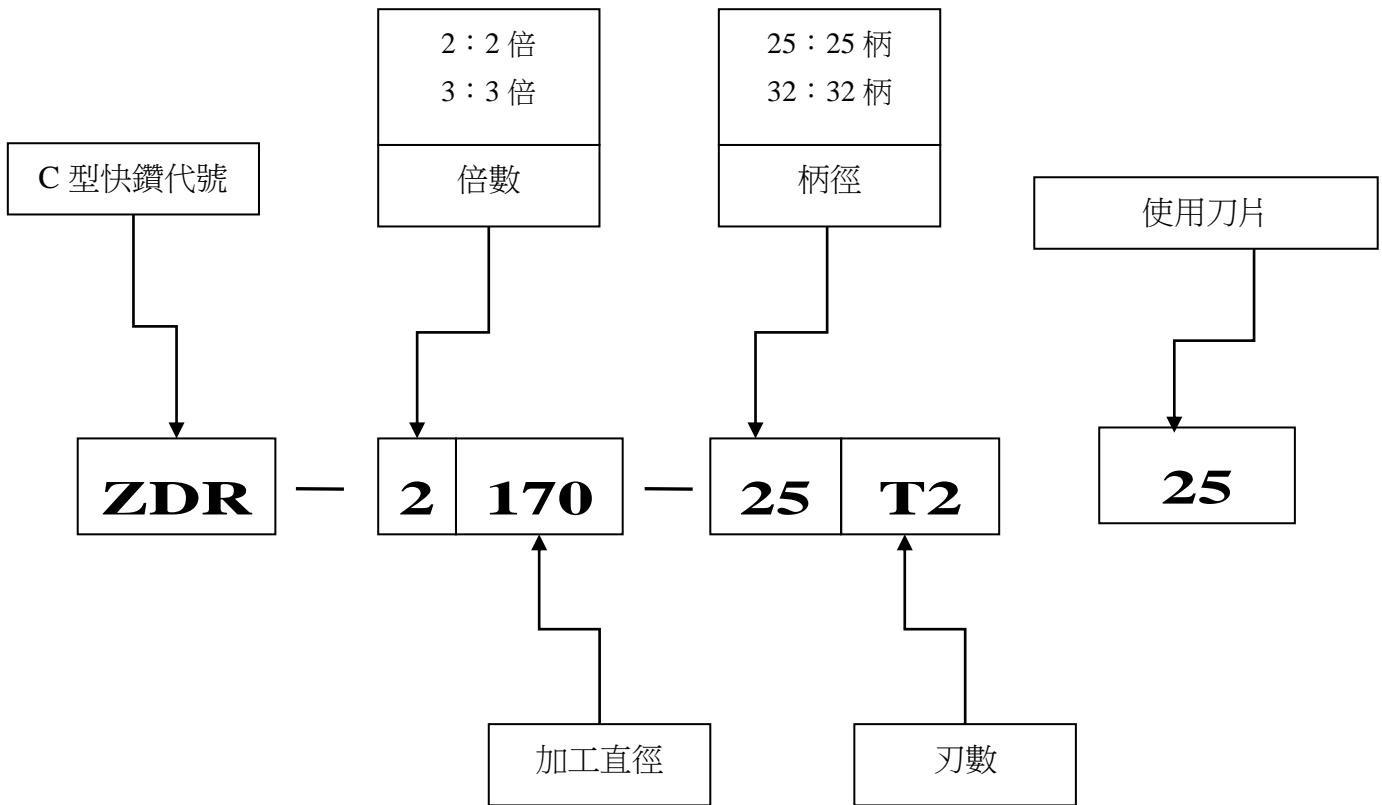

# Zy C 型快鑽-2 倍 C Type Speed Drills

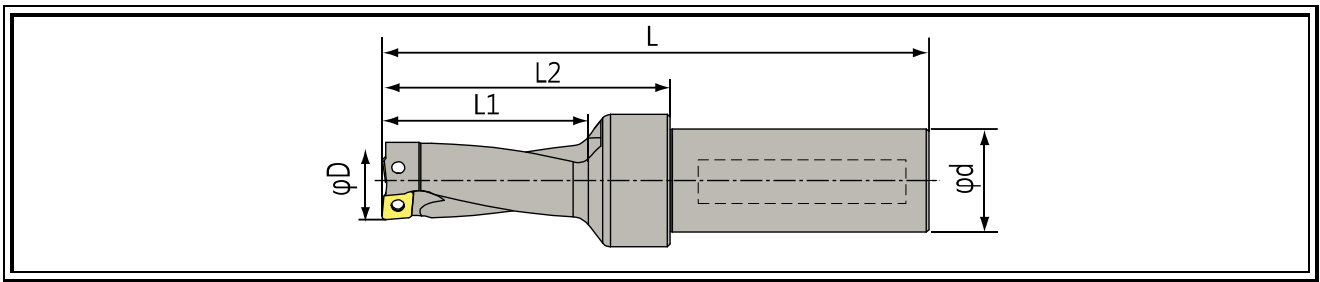

Stock	型號 Model No.	D	d	L	L1	L2	螺絲 Screw	Wrench	刀片 Insert
●	ZDR-2120-20T2-WD04	12	20	104	27	48	M1.8x4.0x2.5-54	T6	WD042004
●	ZDR-2130-20T2-WD04	13		106	29	50			
●	ZDR-2140-20T2-WD04	14		108	31	52			
●	ZDR-2120-25T2-WD04	12	25	104	27	48			
●	ZDR-2130-25T2-WD04	13		106	29	50			
●	ZDR-2140-25T2-WD04	14		108	31	52			
●	ZDR-2150-25T2-CP05	15	25	110	33	54	M2.2x5.1x3.1	T7	CP050204
●	ZDR-2160-25T2-CP05	16		112	35	56			
●	ZDR-2170-25T2-CP05	17		114	37	58			
●	ZDR-2170-25T2-CC06	17	25	114	37	58	M2.5x6.0x3.6	T8	CC060208
●	ZDR-2180-25T2-CC06	18		116	39	60			
●	ZDR-2190-25T2-CC06	19		118	41	62			
●	ZDR-2200-25T2-CC06	20		120	43	64			
●	ZDR-2210-25T2-CC06	21		122	45	66			
●	ZDR-2220-25T2-CP08	22	25	124	47	68	M3x7.8x4.1	T9	CP080208
●	ZDR-2230-25T2-CP08	23		126	49	70			
●	ZDR-2240-25T2-CP08	24		128	51	72			
●	ZDR-2250-25T2-CP08	25		130	53	74			
●	ZDR-2260-25T2-CP08	26		132	55	76			
●	ZDR-2270-32T2-CP08	27	32	134	57	78	M4x10.6x5.6	T15	CC09T308
●	ZDR-2280-32T2-CP08	28		136	59	80			
●	ZDR-2290-32T2-CC09	29	32	138	61	82			
●	ZDR-2300-32T2-CC09	30		140	63	84			
●	ZDR-2310-32T2-CC09	31		142	65	86			
●	ZDR-2320-32T2-CC09	32		144	67	88			
●	ZDR-2330-32T2-CC09	33		146	69	90			
●	ZDR-2340-32T2-CC09	34		150	71	92			

# Zy C 型快鑽-3 倍 C Type Speed Drills

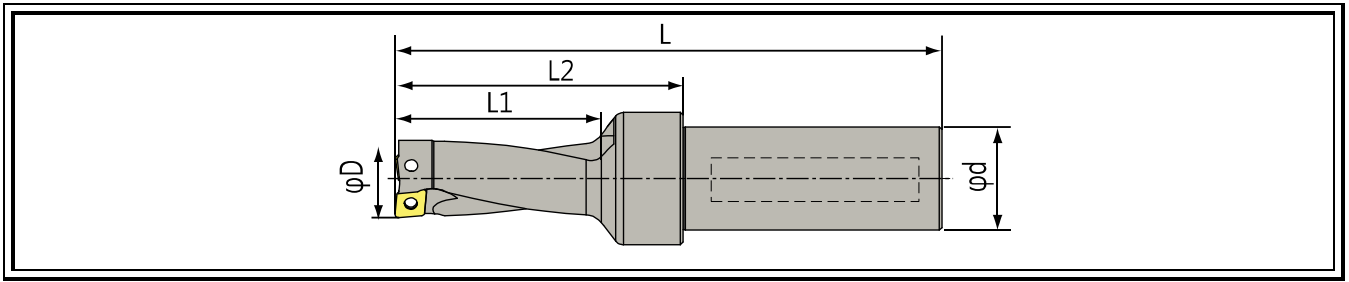

Stock	型號 Model No.	D	d	L	L1	L2	螺絲 Screw	板手 Wrench	刀片 Insert
●	ZDR-3120-20T2-WD04	12	20	116	39	60	M1.8x4.0x2.5-54	T6	WD042004
●	ZDR-3130-20T2-WD04	13		119	42	63			
●	ZDR-3140-20T2-WD04	14		122	45	66			
●	ZDR-3120-25T2-WD04	12	25	116	39	60			
●	ZDR-3130-25T2-WD04	13		119	42	63			
●	ZDR-3140-25T2-WD04	14		122	45	66			
●	ZDR-3150-25T2-CP05	15	25	125	48	69	M2.2x5.1x3.1	T7	CP050204
●	ZDR-3160-25T2-CP05	16		128	51	72			
●	ZDR-3170-25T2-CP05	17		131	54	75			
●	ZDR-3170-25T2-CC06	17	25	131	54	75	M2.5x6.0x3.6	T8	CC060208
●	ZDR-3180-25T2-CC06	18		134	57	78			
●	ZDR-3190-25T2-CC06	19		137	60	81			
●	ZDR-3200-25T2-CC06	20		140	63	84			
●	ZDR-3210-25T2-CC06	21		143	66	87			
●	ZDR-3220-25T2-CP08	22	25	146	69	90	M3x7.8x4.1	T9	CP080208
●	ZDR-3230-25T2-CP08	23		149	72	93			
●	ZDR-3240-25T2-CP08	24		152	75	96			
●	ZDR-3250-25T2-CP08	25		155	78	99			
●	ZDR-3260-25T2-CP08	26		158	81	102			
●	ZDR-3270-32T2-CP08	27	32	161	84	105	M4x10.6x5.6	T15	CC09T308
●	ZDR-3280-32T2-CP08	28		164	87	108			
●	ZDR-3290-32T2-CC09	29	32	167	90	111			
●	ZDR-3300-32T2-CC09	30		170	93	114			
●	ZDR-3310-32T2-CC09	31		173	96	117			
●	ZDR-3320-32T2-CC09	32		176	99	120			
●	ZDR-3330-32T2-CC09	33		179	102	123			
●	ZDR-3340-32T2-CC09	34		182	105	126			



# Zy 扭力扳手 Torque Screwdriver

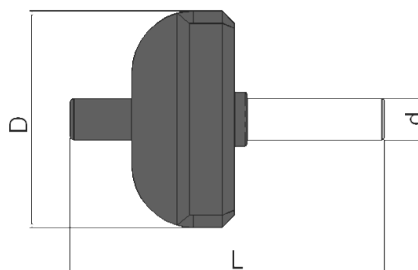
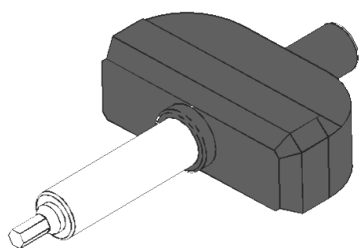

## 特點

1. 適用於需要固定扭力設定要求的工業和工作。
2. 符合人體工學的 T 型握把設計，操作容易，使用安全。
3. 更換式焊接，方便使用者依不同使用場合而調整。
4. 當施力到固定扭力時，握把會有一回轉力及”喀擦”聲來提醒使用者，以避免超過扭力值而造成物件損壞。

## T 型握把 T-Handle

型號 Model No.	D	d	L	建議使用起子頭 Bits Torx	N. M	In-Ib
TW-05	52	10	76.25	T5	0.6	5.3
TW-06				T6	0.6	5.3
TW-09				T7	0.9	8
TW-12				T8	1.2	10.6
TW-14				T9	1.4	12.4
TW-20				T10	2	17.7
TW-30				T15	3.0	26.6
TW-50				T20	5.0	44.3

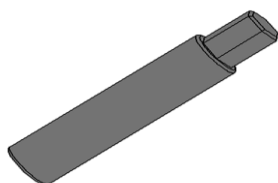

型號 Model No.	d	L	L1	S
BIT-1/4" -50L	10	50	10	1/4"

## 使用說明

- 此扭力起子除了可接各種標準型的起子頭(如圖一所示), 亦可接上延長焊接增加長度(如圖二所示), 而延長焊接也可接各種標準型起子頭(如圖三所示)。
- 順時鐘旋轉扳手 Wrench 起子握把(如圖四所示), 扭力達大最大值時會有”喀擦”聲音來提醒使用者, 避免超過扭力值, 而造成物件損壞, 握法分別有低扭力握法(如圖五所示)以及高扭力握法(如圖六所示)兩種。

**起子頭 25mm & 50mm**      採用 S-2 高級合金鋼製造, 硬度可達 HRC60°



圖 1

圖 2

型號 Model No.	d	L	S	型號 Model No.	d	L	S
BIT-T5-25L	T5	25	1/4"	BIT-T5-50L	T5	50	1/4"
BIT-T6-25L	T6			BIT-T6-50L	T6		
BIT-T7-25L	T7			BIT-T7-50L	T7		
BIT-T8-25L	T8			BIT-T8-50L	T8		
BIT-T9-25L	T9			BIT-T9-50L	T9		
BIT-T10-25L	T10			BIT-T10-50L	T10		
BIT-T15-25L	T15			BIT-T15-50L	T15		
BIT-T20-25L	T20			BIT-T20-50L	T20		

**使用說明:**

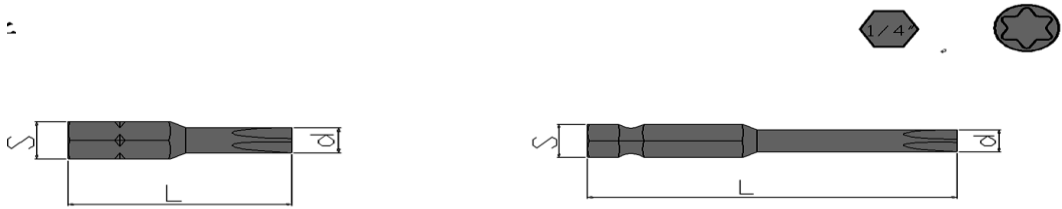
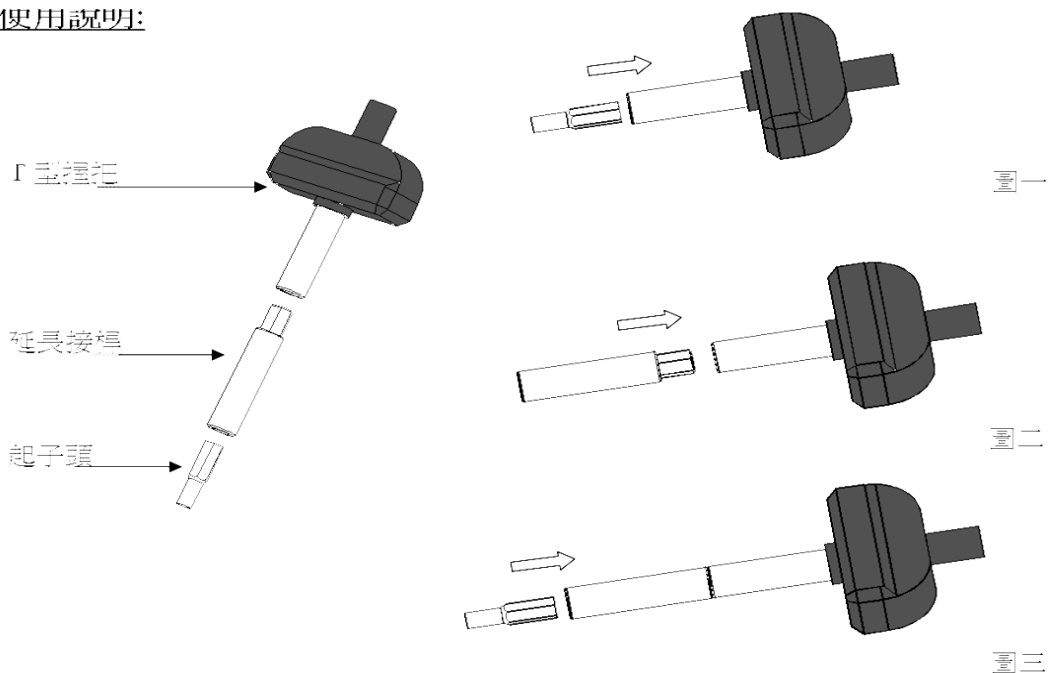

# Zy 內圓球面與內圓端面應用

1. 加工方法		精加工
<p>無預鑽孔的情況下</p> <p>球面加工</p> <p>內圓端面加工</p> <p>(注) 內圓端面加工時，進刀量依定要低於<math>0.05\text{mm/rev}</math></p>		<p>球面加工</p>
<p>有預鑽孔的情況下</p> <p>球面加工</p> <p>內圓端面加工</p> <p>鑽孔</p> <p>(注) 內圓端面加工時，進刀量依定要低於<math>0.05\text{mm/rev}</math></p>		<p>內圓端面加工</p> <p>加工工序</p> <ol style="list-style-type: none"> <li>1.先做好圓端面精加工。</li> <li>2.再做內孔徑精加工。</li> </ol>
2. 加工的注意事項		
<p>當刀片超過加工徑內圓的中心時，刀片可能會崩損。</p>	<p>調整刀尖位置，使刀尖對應到加工的0點位置</p> <p>加工半徑要依刀尖圓弧半徑R的不同作小量調整。</p>	<p>小於刀尖圓弧半徑R</p> <p>切深"<math>a</math>"大於刀尖圓弧半徑R時，往往會產生毛刺。</p>
<p>這種加工方法是可行的，但是斜線部分可能會被切削刮傷。</p> <p>泛白</p>		